



## In-Person Take Home Notebooks [Electronic Version]

Thank you for volunteering with Heart Tutoring this year! This packet includes a digital copy of the 6 Heart Math Tutoring concept notebooks. Physical copies and math manipulatives are provided to you at your tutoring site for tutoring.

Included in this packet you will find the following 6 concept notebooks (*Clicking the notebook name below will take you to the respective notebook*):

- [Counting](#)
- [More or Less](#)
- [Combinations to 10](#)
- [Strategies to 20](#)
- [Place Value](#)
- [Understanding Multiplication and Division](#)

As you prepare for your lessons, please note the following:

- Please read the “Concept Overview” page that is located at the beginning of each notebook before starting a concept notebook with your student(s). It provides the goals of the notebook along with key points.
- At the beginning of each lesson, there is an overview page that includes the goals for that lesson, what activities you will be playing, and what materials are needed. It also includes “Wrap-Up” questions that you can ask your student on the way back to class.

Please reach out to your Program Coordinator with any questions and have fun tutoring!



HEART  
MATH TUTORING

Lessons and Activities for

# Counting

*Volunteer Check-Out Materials*

The materials in this notebook are to be used only in conjunction with Heart Math Tutoring. Please contact the administrator of this program before reproducing any materials found in this notebook.

# COUNTING AND NUMBER RECOGNITION

## Concept Overview

### CONCEPT GOALS

*Student will be able to:*

1. Count objects consistently and accurately.
2. Recognize and understand numerals.
3. Determine "one more" and "one less" without counting.
4. Recognize that smaller numbers are contained within larger numbers.
5. Solve word problems that involve counting.

### END OF PROGRAM ASSESSMENT

*Knowing how students will be assessed can help guide instruction.*

**Example:** Student will be asked to count out a pile of cubes (between 20 and 30) and report the number counted with ease. Then they will be asked to say the resulting number when one cube is taken away, without recounting the pile.

### KEY POINTS

*The information below may assist you in helping your student.*

- "Counting is more than reciting a rote sequence and recognizing numerals. Counting is finding out 'how many.'" – Kathy Richardson, How Children Learn Number Concepts: A Guide to the Critical Learning Phases, 2012.
  - For example, when you place three counters out for a child and have them count them "One, Two, Three", they may have named or labeled the first object, "One," and the next object "Two," and the next, "Three." When you ask him/her to show you three, instead of scooping up all three counters and showing you three, they will show you the one counter that they labeled "Three."
  - Young children also often do not realize that they need to keep track of what has and has not been counted.
- Students need practice associating real objects with numerals to discover meaning behind quantities.
- Hands-on practice with real objects should help students become able to tell whether an estimate is reasonable, count consistently and accurately, and see and use relationships between numbers.

## GOALS

*Student will be able to:*

1. Count objects consistently and accurately.
2. Recognize and understand numerals.
3. Solve word problems that involve counting.

## ACTIVITIES

*The time required to complete each activity will vary from student to student. Allow student to move at their own pace. If more time is needed, lessons can be carried over to the next tutoring session.*

### **Counting and Rearranging Objects**

### **Counting Stories**

### **Red Cards Win!**

### **Let's Connect**

## MATERIALS ENCLOSED

Blank Ten Frame

## MATERIALS TO GET

Connecting Cubes (2 bags,  
different colors)

Yellow Number Cube (1-6)

Deck of Cards

Paper and pencil

Let's Connect Packet  
for Counting

## WRAP-UP

- Compliment student for hard work and provide stickers as a reward.
- Discuss with student the lesson goals that were practiced today.
- Ask student two of the following questions on the way back to class:
  - What was hard about today?
  - What did you feel confident about?
  - Where did you see improvement?
  - What do you still need to practice?
  - How do you feel about your effort today?
- Encourage students to practice counting objects at home.
- Record brief notes on progress log.



## Counting and Rearranging Objects

**Materials:** Connecting Cubes (1 bag) / Yellow Number Cube (1-6) / Blank Ten Frame

**Purpose:** Student practices building the same number in different ways to discover that object distribution does not affect the quantity.

### **PART I:**

Ask student to roll the Number Cube and to put that number of Connecting Cubes on the Ten Frame.

Rearrange the cubes on the frame and ask,

**“How many cubes are on the Ten Frame now?”**

Ask student to rearrange the cubes in a third way. If student struggles, demonstrate a third way to rearrange the cubes.

Example for 5

■	■	■	■	■

■	■	■		
■	■			

	■	■	■	
	■		■	

Repeat by rolling the Number Cube to generate several more numbers.

### **PART II:**

Ask student to roll the Number Cube and to hold up their fingers to show the number on the cube. Then ask student to use different fingers to show the same number. If student struggles, ask questions to prompt thinking. For example, **“If I show three fingers on my left hand and two fingers on my right, how many fingers am I showing? What if I show my left thumb and four fingers on my right hand?”**

Example for 6:

Student shows:

One hand with 5 fingers and one hand with 1 finger.

Both hands with 3 fingers.

One hand with 4 fingers and one hand with 2 fingers

## Counting Stories

**Materials:** Connecting Cubes (2 bags, different colors)

**Purpose:** Student practices counting to tell *how many*.

**NOTE:** The stories below are not meant to be used as addition problems but rather should be used to allow student to practice counting by ones.

Tell student,

**“Today we are going to make up stories that require counting. Then you will use cubes to show the story and find the answer.”**

Share some of the suggested situations below. Ask student to pick one of the situations or to make up their own.

Fish in the ocean

Tigers in a cage

Ducks on a pond

Dinosaurs out for a walk

Children on the playground

Students on a bus

Birds in a tree

Make up a story that involves counting and ask student to model the story using counters as shown in examples below:

Example 1:

Tutor says,

**“3 girls and 4 boys are riding on the bus.”**

Wait for student to use 3 cubes to represent boys and 4 cubes to represent girls.

Then ask,

**“How many children were riding on the bus?”**

Student should count all of the cubes.

Example 2:

Tutor says,

**“One dinosaur walked down to the lake and met five more dinosaurs at the lake.”**

Wait for student to use cubes to act out the story.

Then ask,

**“How many dinosaurs were at the lake?”**

Repeat with several more stories. Encourage student to make up their own counting stories.

HEART MATH TUTORING

## Red Cards Win!

**Materials:** Deck of Cards / Paper and pencil

**Purpose:** Student practices counting to tell *how many*.

Ask student to count out 26 cards for each player.

Each player sorts their cards by color and counts how many of each color they have.

The player with more red cards is the winner!

Play several times, writing on paper to keep track of "wins."

**NOTE:** *If student struggles, play with fewer cards.*

## Let's Connect!

**Materials:** Let's Connect Packet for Counting (*enclosed in Student Progress Folder*) / Word Problem Guide Card (*pink card on cart*) / Paper and pencil

**Purpose:** Student practices standards-aligned content to continue reinforcing and developing skills and concepts.

- 1) Together with student, complete one page (four squares) in the **Let's Connect** Counting packet.
- 2) For any word problems, use the pink Word Problem Card (*found on the cart*) as a guide for how to talk about and work through the problems in a meaningful way.
- 3) Refer to the green **Let's Connect** Counting **Answer Key** (*found on the cart*) to check student work and answers.

## GOALS

*Student will be able to:*

1. Count objects consistently and accurately.
2. Recognize and understand numerals.
3. Solve word problems that involve counting.

## ACTIVITIES

*The time required to complete each activity will vary from student to student. Allow student to move at their own pace. If more time is needed, lessons can be carried over to the next tutoring session.*

**Make – Break – Match**

**Large Handfuls**

**Let's Connect**

## MATERIALS ENCLOSED

Number Path (1-10)

Number Cards (1-30)

Ten Frame Cards for Counting

## MATERIALS TO GET

Connecting Cubes (3 bags of one color, 1 bag of a different color)

10 Red bowls

2 Yellow Dot Cubes (1-6)

Paper and pencil

## IN PROGRESS FOLDER

Let's Connect Packet  
for Counting

## WRAP-UP

- Compliment student for hard work and provide stickers as a reward.
- Discuss with student the lesson goals that were practiced today.
- Ask student two of the following questions on the way back to class:
  - What was hard about today?
  - What did you feel confident about?
  - Where did you see improvement?
  - What do you still need to practice?
  - How do you feel about your effort today?
- Encourage students to practice counting objects at home.
- Record brief notes on progress log.

## Make – Break – Match

**Materials:** Connecting Cubes (3 bags of the same color) / Number Path (1-10) / 10 Red bowls / Ten Frame Cards for Counting / 2 Yellow Dot Cubes (1-6)

**Purpose:** Student practices counting out quantities and relating quantities to numbers.

### PART I: Making Towers

Place a Number Path (1-10) on the table in front of student and ask them to make a tower to match each number, starting with 1 and going in order to 10. Feel free to help them create the towers to speed up the process.

After each tower is made, ask student to place the tower behind the matching number as shown below.



**NOTE:** If student struggles to count out the correct number, encourage them to go slowly and to count out loud as they collect each cube.

When all the towers have been made, ask student to describe what the towers look like.

Compliment student on their answer. Emphasize the number relationships by saying,

**“Going up, each tower has *one more* than the tower before it. Going down, each tower has *one less*.”**

### **PART II: Breaking Towers**

Ask student to pick one of the towers, break the cubes apart and put them in a pile. Have student count the cubes as they put them in the pile. Place a bowl over the pile of cubes to hide them.

Repeat until all the towers have been broken apart and all the cubes are hidden under the bowls.

### **PART III: The Matching Game**

Mix up the bowls so no one can remember which quantity is under which bowl.

Place the Ten Frame Cards face down on the table. Tutor and student take turns turning over a Ten Frame Card and then choosing a bowl to try to find the matching quantity.

Ask student to count the quantity on the Ten Frame Card and then to count the quantity under the bowl for each turn. If someone makes a match, they keep the card and remove that bowl of cubes out of play. If a match is not made, the card goes back to the bottom of the stack.

The person with the most Ten Frame Cards at the end is the winner.

#### **Variation:**

Play the Matching Game using 2 Yellow Dot Cubes (1-6) instead of Ten Frame Cards. Roll the cubes, count the dots, and find a match. If 11 or 12 are rolled, let the student count the dots, but know that there will not be a matching bowl.

*PLEASE RETURN 20 SAME COLOR CONNECTING CUBES TO EACH BAG.*



## Large Handfuls

**Materials:** Connecting Cubes (3 bags of the same color) / Number Cards (1–30) / Number Path (1–10) / Paper and pencil

**Purpose:** Student practices keeping track of an unorganized pile and counting to find out how many.

### **PART I: Counting by 1s**

Break apart 60 Connecting Cubes and place in pile on table. Ask student to take 3 handfuls of Connecting Cubes and place them in a separate pile (about 15 cubes).

Ask student,

**“How many cubes do you think are there? Make a guess or estimate, before counting.”**

Ask student to count the cubes. When student finishes counting, ask,

**“How many are there?”**

If student struggles, help them recount or correct errors.

Find the Number Card that matches and place it beside the pile as a label.

Discuss whether the initial estimate was close to the actual number of Connecting Cubes. Reference Number Path as a visual aid if needed.

Repeat several times, asking students to take out larger handfuls of Connecting Cubes (quantities up to 30).

*Notice the following things about your student and compliment them as progress is made.*

- *Does student realize the importance of keeping track of the cubes while counting (no double-counting or missing any cubes)?*
- *Does student know “how many” after counting?*
- *Does student correct their estimate while counting, if their estimate was significantly off?*

### **PART II: Grouping by 2s, 5s and 10s**

Tell student,

**“Sometimes organizing objects into groups helps when you are counting. Let’s try it.”**

**NOTE:** Some students will not yet trust that the total remains the same despite how the cubes are arranged or grouped. This activity helps address that misconception.

Ask student to take 3 or 4 handfuls of cubes (about 15 – 30 cubes) and put them in a pile. Put aside any remaining cubes and work only with the selected pile throughout the remainder of the activity.

Ask student to count the cubes one at a time and to write the total on a piece of paper.

Ask student to organize the cubes into groups of 2 and count again. If there are an odd number of cubes, explain that the extra cube must be added on at the end.

Some students will know the sequence of counting by 2s easily (2, 4, 6, 8, 10) and others will need to count by ones despite the organized piles of 2. Either way is fine.

Then ask,

**“Is that the same amount you counted before?”**

Put the cubes back into an unorganized pile.

Ask student to organize the cubes into groups of 5 and count again. If there are leftovers at the end, explain how to count them.

Some students will know the sequence of counting by 5s (5, 10, 15, etc.) and others will need to count by ones despite the organized piles of 5. Either way is fine.

Then ask,

**“Is that the same amount you counted before?”**

Ask student to organize the cubes into groups of 10 and count again. If there are leftovers at the end, explain how to count them.

Some students will know the sequence of counting by 10s (10, 20, etc.) and others will need to count by ones despite the organized piles of 10. Either way is fine.

Repeat several times with different large piles.

PLEASE RETURN 20 SAME COLOR CONNECTING CUBES TO EACH BAG.

## Let's Connect!

**Materials:** Let's Connect Packet for Counting (*enclosed in Student Progress Folder*) / Word Problem Guide Card (*pink card on cart*) / Paper and pencil

**Purpose:** Student practices standards-aligned content to continue reinforcing and developing skills and concepts.

- 1) Together with student, complete one page (four squares) in the **Let's Connect** Counting packet.
- 2) For any word problems, use the pink Word Problem Card (*found on the cart*) as a guide for how to talk about and work through the problems in a meaningful way.
- 3) Refer to the green **Let's Connect** Counting **Answer Key** (*found on the cart*) to check student work and answers.

## GOALS

*Student will be able to:*

1. Count objects consistently and accurately.
2. Recognize and understand numerals.
3. Determine "one more" and "one less" without counting.
4. Solve word problems that involve counting.

## ACTIVITIES

*The time required to complete each activity will vary from student to student. Allow student to move at their own pace. If more time is needed, lessons can be carried over to the next tutoring session.*

### Show and Build

### Show Me the Number

### Where on the Number Line?

### Knowing One More and One Less

### Let's Connect

## MATERIALS ENCLOSED

Number Cards (1–30)

Number Path (1–30)

Blank Ten Frame

Ten Frame Cards for Counting

## MATERIALS TO GET

Connecting Cubes (2 bags of one color, 1 bag of different color)

+/- Cube

Paper and pencil

## IN PROGRESS FOLDER

Let's Connect Packet  
for Counting

## WRAP-UP

- Compliment student for hard work and provide stickers as a reward.
- Discuss with student the lesson goals that were practiced today.
- Ask student two of the following questions on the way back to class:
  - What was hard about today?
  - What did you feel confident about?
  - Where did you see improvement?
  - What do you still need to practice?
  - How do you feel about your effort today?
- Encourage students to practice counting objects at home.
- Record brief notes on progress log.

## Show and Build

**Materials:** Connecting Cubes (1 bag) / Blank Ten Frame / Ten Frame Cards for Counting / Paper and pencil

**Purpose:** Student practices counting and experiments with number relationships.

### PART I: Show and Build

Tell student,

**“You played a matching game recently with Ten Frame Cards and cubes. Today we are going to use the same cards to play ‘Show and Build’.**

**I am going to show you a Ten Frame Card and ask you to build what you see on your Blank Ten Frame. Then I’m going to show you a second Ten Frame Card and ask you to change your cubes to match the second Ten Frame Card.**

**Let’s give it a try.”**

Example for changing 5 to 7:

Show student a Ten Frame Card with 5 dots and ask them to use cubes to fill their Blank Ten Frame to match it. Then show student a Ten Frame Card with 7 dots and ask them to change the cubes on their Ten Frame to match the second card. Leave the 5 and 7 Ten Frame Cards on the table for student to examine if needed.

Ask student,

**“How many cubes did you put on the Ten Frame to start out?”**

**“How many cubes do you have on your Ten Frame now?”**

**“What did you do to change to the second number?”**

**NOTE:** The goal is to allow student to practice counting and to experiment with number relationships. Allow student to perform the tasks however they choose. Many students will struggle to explain how they changed the cubes. If student struggles, ask questions to prompt thinking. Some possible student answers are provided below:

*“I started over and put 7 cubes on the Ten Frame.”*

*“I counted the cubes that were on the frame and I continued to add cubes until I had 7.”*

*"I knew I had 5 cubes, so I added two more to make the 7."*

Repeat this activity using different Ten Frame Cards for as long as it seems challenging to student, sometimes changing to larger numbers and sometime changing to smaller numbers.

### **PART II: Flash and Build**

If student is successful with the above activity, change it by showing the second Ten Frame Card quickly. Allow enough time for student to count the dots on the card, but do not leave the cards on the table while student is working with the cubes.

If student struggles, bring the cards back out for closer examination.

Repeat the activity using different Ten Frame Cards.

### **PART III : Write and Build to 10**

If student is successful with the above activities, ask them to build numbers on the Blank Ten Frame as follows:

- Write down a number between 1 and 10 and ask student to build it.
- Write down a second number between 1 and 10 and ask student to change the cubes on the frame to make the second number.

Ask student,

**"What did you do to change the first number to the second?"**

**NOTE:** *The goal is to allow student to practice counting and to experiment with number relationships. Allow student to perform the task however he/she chooses. If student struggles, ask questions to prompt thinking.*

Repeat activity several times, sometimes changing to larger numbers and sometimes changing to smaller numbers.

## Show Me the Number

**Materials:** Connecting Cubes (2 bags of the same color) / Number Cards (1-30) / Number Path (1-30)

**Purpose:** Student practices counting out a particular quantity.

**NOTE:** Counting out a particular quantity is a different skill from counting a group of objects to determine how many. It requires students to remember the requested number while counting and therefore attribute meaning to that number. Often, students will count past the requested number, begin to self-correct, and only later be able to easily count out the particular quantity.

Tell student,

**“Today we’re going to use Connecting Cubes to represent different objects and you are going to show me the number of objects I ask for.”**

Ask student to decide what they want the Connecting Cubes to represent. Offer suggestions if needed (candy, animals, stickers, children, etc.).

**“Let’s pretend these cubes represent \_\_\_\_\_.”**

Ask student to show you various quantities, beginning with numbers between 5 -15, progressing to numbers between 15 – 25 and then to numbers between 25 – 35, as student is able.

Example:

**“Please show me 9 fish.”**

Student does not need to line up or connect the cubes. Rather, they should understand that a loose pile of 9 has the same value as a straight line of 9.

Watch student work until they stop counting and announces they are finished. Observe whether student correctly finishes at 9, counts past 9, counts past and self-corrects, or loses track of the number altogether. If student struggles:

- Ask student to count aloud so that you can help catch any mistakes.
- Ask student to set the cubes they have counted onto a piece of paper to encourage accuracy and organization.
- Suggest using Number Path (1-30) as a visual aid. Student can put one cube on each number of the line.
- For a student who struggles with organization, suggest they put the cubes onto a sheet of paper as they count them. This will help the student keep track of which cubes have been included in the total count and which have not.

Give student help and additional practice, moving to higher numbers, as they are ready.

**Variation:**

Draw Number Cards between 10 and 30 to determine the amount student should count out.

## Where on the Number Line?

**Materials:** Number Cards (1-20) / Paper and pencil

**Purpose:** Student practices putting numbers 1-20 in order to explore number relationships.

Shuffle and place Number Cards face down in a pile.

Student and tutor take turns picking a card from the pile and placing it on the table to make a single number line of 1 - 20.

Each card should be placed to the right or left of the cards already on the table according to where it would go on the number line, leaving the correct numbers of spaces between them.

When a number is picked that can go directly beside a number that is already on the table, the person who places that card gets a point. If it goes directly between two cards, the person gets two points.

Keep track of points using pencil and paper. The person with the most points after all the cards are placed is the winner.





## Knowing One More and One Less

**Materials:** Connecting Cubes (2 bags of the same color) / Number Cards (1-30) / Number Path (1-30) / +/- Cube

**Purpose:** Student practices knowing how many items result when adding one more or taking one away.

**NOTE:** For the activity below, begin with low Number Cards but move to higher Number Cards as soon as student is able.

Tell student:

**"Pick a Number Card and build a train that has the same number of cubes."**

Put the Number Card visibly next to the train, as a label.

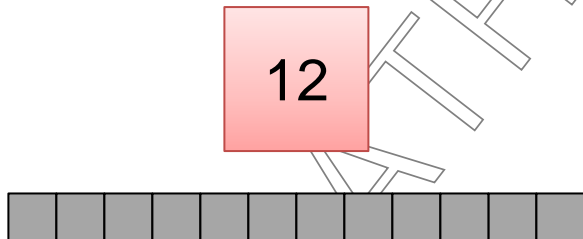

Ask student to roll the +/- Cube to determine whether one cube will be added to or taken away from the existing train.

Ask student to say how long the resulting train will be.

Example:

If student rolls a +, say,

**"You rolled a +. If I add one cube to the train, how long will the new train be?"**



If student knows the new total without recounting, repeat the activity using a variety of Number Cards.

If student does not know the new total and/or guesses the wrong number, have student count the cubes in the train to figure out the answer and then explore the Number Line as a way to help predict the answer as shown below.

Show student the Number Path and say,

**“The Number Path can help you see what happens when we add or take away a cube. Point to the number that matches how long the train was at first, and then how long the train was after I added one more.”**

1	2	3	4	5	6	7	8	9	10
11	12	13	14	15	16	17	18	19	20
21	22	23	24	25	26	27	28	29	30

↑   ↑

Talk about the fact that the numbers are right beside each other.

Repeat activity for different length trains, allowing student to use the Number Path as a resource when necessary.

HEART MATH

## Let's Connect!

**Materials:** Let's Connect Packet for Counting (*enclosed in Student Progress Folder*) / Word Problem Guide Card (*pink card on cart*) / Paper and pencil

**Purpose:** Student practices standards-aligned content to continue reinforcing and developing skills and concepts.

- 1) Together with student, complete one page (four squares) in the **Let's Connect** Counting packet.
- 2) For any word problems, use the pink Word Problem Card (*found on the cart*) as a guide for how to talk about and work through the problems in a meaningful way.
- 3) Refer to the green **Let's Connect** Counting **Answer Key** (*found on the cart*) to check student work and answers.

## GOALS

*Student will be able to:*

1. Count objects consistently and accurately.
2. Recognize and understand numerals.
3. Determine *one more* and *one less* without counting.
4. Recognize that smaller numbers are contained within larger numbers.
5. Solve word problems that involve counting.

## ACTIVITIES

*The time required to complete each activity will vary from student to student. Allow student to move at their own pace. If more time is needed, lessons can be carried over to the next tutoring session.*

### **Measuring Objects**

### **Counting Forward and Backward Game**

### **Mystery Train for Counting**

### **Let's Connect**

## MATERIALS ENCLOSED

Number Cards (1–30)

Number Path (1–30)

## MATERIALS TO GET

Connecting Cubes (3 bags of one color, 1 bag of a different color)

Paper and pencil

## IN PROGRESS FOLDER

Let's Connect Packet  
for Counting

## WRAP-UP

- Compliment student for hard work and provide stickers as a reward.
- Discuss with student the lesson goals that were practiced today.
- Ask student two of the following questions on the way back to class:
  - What was hard about today?
  - What did you feel confident about?
  - Where did you see improvement?
  - What do you still need to practice?
  - How do you feel about your effort today?
- Encourage students to practice counting objects at home.
- Record brief notes on progress log.

## Measuring Objects

**Materials:** Connecting Cubes (2 bags of the same color) / Paper and pencil

**Purpose:** Student practices counting numbers greater than 20 and estimating quantities.

Tell student,

**“Today we are going to practice counting by measuring things with Connecting Cubes.”**

Make a recording sheet that looks like the following:

<i>Object</i>	<i>Length</i>
---------------	---------------

Example 1:

Demonstrate how to measure the height of a chair by making a train of Connecting Cubes to match the height and counting the cubes in the train. Ask the student to tell you the height of the chair.

**“The height is 22 Connecting Cubes long.”**

Record on sheet:

<i>Object</i>	<i>Length</i>
<i>Chair Height</i>	<i>22 Cubes</i>

Example 2:

Ask student,

**“How many cubes do you think match the length of your arm?”**

Notice whether student’s estimate seems reasonable. Help student measure their arm by making a train of Connecting Cubes to match the length. Notice whether student adjusts their estimate while measuring.

If student’s estimate was unreasonable and they do not adjust while measuring, prompt them while they are halfway through by asking,

**“Do you want to change your estimate?”**

Add measurement to recording sheet:

<i>Object</i>	<i>Length</i>
<i>Chair Height</i>	<i>22 cubes</i>
<i>My Arm</i>	<i>?? cubes</i>
<i>...</i>	

Example 3:

Ask student,

**“How many cubes do you think match the width of your desk/table?”**

Notice whether student’s estimate seems reasonable. Help student measure the desk/table by making a train of Connecting Cubes to match the length. Notice whether student adjusts their estimate while measuring.

If student’s estimate was unreasonable and they do not adjust while measuring, prompt them when they are halfway through by asking,

**“Do you want to change your estimate?”**

Add to recording sheet:

<i>Object</i>	<i>Length</i>
<i>Chair Height</i>	<i>22 cubes</i>
<i>My Arm</i>	<i>?? cubes</i>
<i>My Desk</i>	<i>?? cubes</i>

**Other Examples:**

Using other measurements that would be over 20 cubes, repeat with other objects student chooses. Examples may include side or height of the table, distance from knee to floor, etc. Make sure student is estimating first and then counting correctly.

## Counting Forward and Backward Game

**Materials:** Number Cards (1-30) / Number Path (1-30) / Connecting Cubes (2 bags of the same color)

**Purpose:** Student practices counting forward and backward by one from a given number.

### PART I: Knowing "One More"

Ask student to pick a Number Card between 11 and 30 (yellow or green) and ask if they can tell the number that is *one more* than the number on the card without starting at one and counting up from there.

If student is correct, they keep the card.

If student struggles, they should use the Connecting Cubes to test and determine the correct answer. Student gives card back to tutor.

### PART II: Knowing "One Less"

Same rules as Knowing "One More," but student tells the number that is *one less* than the card picked.

**NOTE:** Use Number Path as a visual aid only if needed.

## Mystery Trains for Counting

**Materials:** Connecting Cubes (3 bags of one color, 1 bag of a different color) / Number Path (1-30) / Paper

**Purpose:** Student explores relationships between numbers by counting *on* rather than counting *all* to find the length of a second train.

Say to student,

**"Today we are going to play a game called Mystery Trains. You have to figure out the length of mystery trains that I will make."**

Example 1:

Tell student:

**"Please join 5 Connecting Cubes of one color together to make a train while I make the mystery trains."**

While student is building their train, tutor builds trains of 6, 8 and 10 cubes with a second color and hide the trains under a sheet of paper.

Tell student,

**"I'm going to show you one of the mystery trains. Can you figure out how many cubes are in the mystery train *without* counting every cube in the train? You can use the train you made to help you measure."**

Move the train of 6 cubes out from under the paper. Place it beside the train of 5 and ask,

**"How many cubes are in the mystery train?"**

Some students will count forward by one from the train of 5 to determine that there are 6. (This process is called *counting on*.) Others will count every cube in the train of 6 to figure out its length.

If student counts every cube in the train of 6 to determine its length, allow them to do so and acknowledge their correct answer. Then, help student see relationships between numbers by asking,

**"I want to see if you can figure out the length of the mystery train without having to count every cube. Let's start with the train you made to help us measure."**



**How many cubes are in the train you made?"** (Student answers 5)

**"Since you know there are 5 cubes in the train you made, how many cubes do you think are in the mystery train?"**

If student does not use the length of the first train (5) to determine the length of the second (6), encourage further reflection by laying the train of 5 on the Number Path and putting the train of 6 beside it. Ask student to think again about where they could start counting to find the total. If student cannot figure it out, model the process of "counting on" from 5 to get 6.

Continue activity by showing student the other two mystery trains and asking the same questions.

Example 2:

Restart the activity, asking student to make a train of 7 cubes while tutor makes mystery trains of 8, 10 and 12.

Example 3:

Restart again, asking student to make a train of 11 cubes while tutor makes mystery trains of 10, 9, and 13. *In this example, student counts back from 11 to determine the length of the train of 10 and train of 9. Counting back may be difficult for student. Use the Number Path as a guide, if needed.*

HEART MATH TUTORING

## Let's Connect!

**Materials:** Let's Connect Packet for Counting (*enclosed in Student Progress Folder*) / Word Problem Guide Card (*pink card on cart*) / Paper and pencil

**Purpose:** Student practices standards-aligned content to continue reinforcing and developing skills and concepts.

- 1) Together with student, complete one page (four squares) in the **Let's Connect** Counting packet.
- 2) For any word problems, use the pink Word Problem Card (*found on the cart*) as a guide for how to talk about and work through the problems in a meaningful way.
- 3) Refer to the green **Let's Connect** Counting **Answer Key** (*found on the cart*) to check student work and answers.

## GOALS

*Student will be able to:*

1. Count objects consistently and accurately.
2. Recognize and understand numerals.
3. Determine *one more* and *one less* without counting
4. Recognize that smaller numbers are contained within larger numbers.
5. Solve word problems that involve counting.

## ACTIVITIES

*The time required to complete each activity will vary from student to student. Allow student to move at their own pace. If more time is needed, lessons can be carried over to the next tutoring session.*

### **Number Cards for Counting**

### **Cereal Game for Counting**

### **Story Problems – One More / One Less**

### **Let's Connect**

***After this lesson is completed, check in with the Program Coordinator to determine if student is ready to move on to the next Concept Notebook.***

## MATERIALS ENCLOSED

Number Cards (1-30)

Number Path (1-10)

Number Path (1-30)

## MATERIALS TO GET

Connecting Cubes (2 bags of one color, 2 bags of a different color)

1 Red bowl

Paper and pencil

## IN PROGRESS FOLDER

Let's Connect Packet  
for Counting

## WRAP-UP

- Compliment student for hard work and provide stickers as a reward.
- Discuss with student the lesson goals that were practiced today.
- Ask student two of the following questions on the way back to class:
  - What was hard about today?
  - What did you feel confident about?
  - Where did you see improvement?
  - What do you still need to practice?
  - How do you feel about your effort today?
- Encourage students to practice counting objects at home.
- Record brief notes on progress log.

## Number Cards for Counting

**Materials:** Connecting Cubes (1 bag) / Number Cards (1-10) / Number Path (1-10)

**Purpose:** Student experiments with number relationships, seeing that smaller numbers are contained within larger numbers and learning to *count on* rather than *count all* to add.

Using only Number Cards 1-10, place cards face down on the table.

Ask student to choose a card and make a tower of that height.

Ask student to choose a second card and *change the tower* to match the number on the second card.

**“Change the tower to match the new number.”**

Allow student to use whatever method they need. Notice the following:

- When going from a smaller number to a larger number, does student add on to the original tower without recounting its cubes, or do they need to start counting again from the beginning? Does student build a whole new stack?

*Ultimately the goal is for student to add on without recounting, but student needs to progress at their own speed.*

- When going from a larger number to a smaller number, does student count back from the original tower, count up from the bottom and take off the extras, or guess and check?

After student changes the tower, ask them,

**“What did you do to change the tower?”**

Repeat exercise with additional Number Cards.

*To make this more fun*, see if the student can get to 10 points, using Connecting Cubes as points each time the new tower is built correctly.

*To make this easier*, suggest placing the first tower on the Number Path and using it as a guide for adding and taking away cubes.

## Cereal Game for Counting



**Materials:** Connecting Cubes / 1 Red bowl / Number Cards (1-30) / Number Path (1-30)

**Purpose:** Student practices counting to tell *how many*.

### Part I: Add One More

Tell student,

**“Pretend these cubes are pieces of cereal and the bowl is your cereal bowl. Pick a Number Card and put that many pieces of cereal in the cereal bowl.”**

Put the Number Card visibly next to the bowl, as a label.

Add one cube to the bowl while saying,

**“If I add one more piece of cereal, how much cereal will we have?”**

If student knows the new total without recounting, repeat activity with additional Number Cards.

If student does not know the new total and/or guesses the wrong number, have student count the cubes in the bowl to figure out the answer and explore the Number Path as a way to help predict the answer as shown below.

Show student the Number Path and say,

**“The Number Path can help you see what happened when we add or take away a piece of cereal. Point to the number that matches how many pieces we had at first and then how many we had after I added one more.”**

Talk about the fact that one number follows the other.

Repeat activity using a variety of Number Cards, encouraging student to use the Number Path as a resource if needed.

### Part II: Take one away

Tell student:

**“We are going to play the same game, but this time I will take one cube away. Pick a number card to get us started.”**

After student picks a card and fills his/her bowl with cubes to match the number, take away one cube while saying:

**“If I take away one piece of cereal, how much cereal will we have?”**

If student knows the new total without recounting, repeat activity using a variety of Number Cards.

If student does not know the new total and/or guesses the wrong number, refer to the Number Path and help student as described above.

Repeat activity using a variety of Number Cards.

## Story Problems – One More / One Less

**Materials:** Connecting Cubes (2 bags of the same color) / Number Path (1-30) / Paper and pencil

**Purpose:** Student practices thinking about *one more / one less* without counting when numbers are presented out of sequence.

**NOTE:** Students at this stage may not trust numbers enough to believe it is possible to know how many there will be before they count. Introducing numbers out of sequence and asking student to practice figuring out one more / one less gives them additional confidence.

### Part I: Knowing One More

Tell student,

**Suzy picked out 9 lollipops at the candy store. Her mother told her to go back to the store and get 1 more lollipop. How many lollipops did Suzy have after she went back to the store?"**

Encourage student to answer the question without using any additional tools but allow time for the student to think. If student cannot answer, ask student to use a loose pile of Connecting Cubes to help them find the answer.

**"Let's say this cube represents one lollipop. Can you show me how many lollipops Suzy picked out at the candy store?"**

Watch student count out the 9 cubes, then ask:

**"How many will she have when she goes back to the store for one more lollipop?"**

Student should add one additional cube to the pile of 9. Observe whether they recount the entire pile before stating the new total (10). If student recounts the pile, help them see the relationship between the numbers by suggesting:

**"Let's look at another way we can see how many lollipops she will have. Look at the Number Path. What number represents how many lollipops Suzy had at first? What number represents how many she had after getting *one more*? Do you notice that the number 10 is right next to the number 9?"**

Move to a problem with higher numbers. For example,

**“There were 14 cars in the parking lot. One more car drove in. How many cars are in the parking lot?”**

Repeat the activity with numbers from 12-30 several times. The eventual goal is for the student to become comfortable answering this type of question (*one more*) without using the Number Path or needing to recount the entire pile.

### **Part II: Knowing One Less**

Tell student,

**“Let’s try another story:**

**Suzy is 9 years old. How old was Suzy last year? She had 1 less year.”**

Encourage student to answer the question without using any additional tools. If necessary, introduce cubes or the Number Path to reinforce student’s answer.

Repeat the activity with numbers from 12-30 several times. The eventual goal is for student to become comfortable answering this type of question (*one less*) without using the Number Path or needing to recount the entire pile.

### **Part III: Story Problems**

Write down a number between 12-30 and ask the student to tell a story in which one item is added or taken away. When student tells the story correctly, compliment them and reinforce the idea that they know how many items will result.

If student seems ready, practice with stories where two items are added or taken away.



## Let's Connect!

**Materials:** Let's Connect Packet for Counting (*enclosed in Student Progress Folder*) / Word Problem Guide Card (*pink card on cart*) / Paper and pencil

**Purpose:** Student practices standards-aligned content to continue reinforcing and developing skills and concepts.

- 1) Together with student, complete one page (four squares) in the **Let's Connect** Counting packet.
- 2) For any word problems, use the pink Word Problem Card (*found on the cart*) as a guide for how to talk about and work through the problems in a meaningful way.
- 3) Refer to the green **Let's Connect** Counting **Answer Key** (*found on the cart*) to check student work and answers.



HEART  
MATH TUTORING

Lessons and Activities for

# More or Less

*Volunteer Check-Out Materials*

The materials in this notebook are to be used only in conjunction with Heart Math Tutoring. Please contact the administrator of this program before reproducing any materials found in this notebook.

# MORE OR LESS

## Concept Overview

### CONCEPT GOALS

*Student will be able to:*

1. Determine which quantity is *more* or *less*.
2. Determine *how many more* and *how many less* one quantity is than another.
3. Understand the language of *more* and *less* and use it correctly in spoken and written sentences and with symbols ( $>$ ,  $<$ ).
4. Describe how to change one number to another number and how to make two groups the same.
5. Count forward from a given number.
6. Count back one or two from a given number.

### END OF PROGRAM ASSESSMENT

*Knowing how students will be assessed can help guide instruction.*

**Example 1:** Student will be shown two piles of Connecting Cubes and asked to tell *how many more* or *how many less* cubes are in one pile compared to the other.

**Example 2:** Student will be shown a series of Number Cards and asked to change a pile of cubes to make it match the number shown on each card. Student will be scored based on how they add to or takes away from the original pile. Do they count forward and count back, or do they need to recount the pile from the beginning?

### KEY POINTS

*The information below may assist you in helping your student.*

- In this concept notebook, students will be working both on the *language* of *more* and *less*, and on the *mathematical concept* of telling the difference between two quantities.
- *More* and *less* are relative terms, relying on which numbers are being compared. This can be confusing to students. Comprehension of *less* can be harder than comprehension of *more* because "thinking about what is *not* there is harder than thinking about what *is* there." – Kathy Richardson, *Developing Number Concepts: Counting, Comparing, and Pattern*, 1999.
- Students will work at different levels. Some students will first need to focus on determining whether one quantity is *more* or *less* than another and later move on to determining *how many more* or *how many less* one number is than another.

## GOALS

*Student will be able to:*

1. Determine which quantity is *more* or *less*.
2. Understand the language of *more* and *less* and use it correctly in spoken and written sentences and with symbols ( $>$ ,  $<$ ).

## ACTIVITIES

*The time required to complete each activity will vary from student to student. Allow student to move at their own pace. If more time is needed, lessons can be carried over to the next tutoring session.*

**Break the Train**

**Building Trains**

**Let's Connect**

## MATERIALS ENCLOSED

*None*

## MATERIALS TO GET

Connecting Cubes (2 bags, different colors)

1 Red Number Cube (4-9)

Synonyms Chart

Paper and pencil

Let's Connect Packet for More or Less

## WRAP-UP

- Compliment student for hard work and provide stickers as a reward.
- Discuss with student the lesson goals that were practiced today.
- Ask student two of the following questions on the way back to class:
  - What was hard about today?
  - What did you feel confident about?
  - Where did you see improvement?
  - What do you still need to practice?
  - How do you feel about your effort today?
- Encourage student to compare quantities at home.
- Record brief notes on progress log.

## Break the Train

**Materials:** Connecting Cubes (1 bag) / Synonyms Chart / Paper and pencil

**Purpose:** Student practices language and symbols for *more*, *less*, and *equal*.

### **PART I:**

Build a train 10 cubes long.  
Break off a piece of your train and show student.



Ask student,

**“How many cubes are in the piece of the train that I broke off?”**

**“How many cubes are left on the train?”**

**“How are the two pieces of the train different?”**

Provide positive feedback for any correct statement. If the student does not use the word *more* or *less* in the sentence describing how the pieces are different, then tell student:

**“We are going to be practicing using the words *more*, *less*, and *equal* when comparing numbers. Let’s write down some words that mean the same thing as *more*, *less*, and *equal*.”**

Use the Synonyms Chart to write down all expressions that student equates with the words *more*, *less*, and *equal*. See examples below.

More	Less	Equal
<i>Bigger</i> <i>Taller</i> <i>Longer</i> <i>más (Spanish)</i> <i>grande (Spanish)</i>	<i>Smaller</i> <i>Shorter</i> <i>Fewer</i> <i>menos (Spanish)</i> <i>pequeño (Spanish)</i> <i>poquito (Spanish)</i>	<i>Same</i> <i>Same size</i> <i>Same length</i> <i>igual (Spanish)</i> <i>match</i>

## **PART II:**

Tutor and student each build a train that is 10 cubes long. Each person then breaks off a piece of their train and compares it to the other person's piece.

Ask student to describe the pieces using complete sentences and the words *more*, *less*, and *equal*, using Synonyms Chart as needed.

### Examples:

"8 is more than 5."

"7 is less than 9."

"4 is equal to 4."

**NOTE:** If student struggles to verbalize a complete sentence, try one of the following: (1) Write a sentence frame on paper to serve as a visual aid (examples below), or (2) Ask student to write the full sentence before saying the sentence aloud.

8 is \_\_\_\_\_ than 5.

7 is \_\_\_\_\_ than 9

4 is \_\_\_\_\_ to 4.

## **PART III:**

Say, "There are math symbols that represent the words *more*, *less*, and *equal*."

Help student add the *more/less/equal* symbols to the chart as shown below:

**NOTE:** A tip for helping students learn the correct direction for the more and less symbols is to compare it to a mouth that opens up to eat the bigger number.

More >	Less <	Equal =
<i>Bigger</i>	<i>Smaller</i>	<i>Same</i>
<i>Taller</i>	<i>Shorter</i>	<i>Same size</i>

Tutor and student each build a train that is 10 cubes long. Then each person breaks off a piece of their train and compares it to the other person's piece.

Ask student to write the word sentence and the number sentence describing whether the quantities are *more*, *less*, or *equal* using pencil and paper. Have student read each number sentence aloud after writing.

### Examples:

6 is more than 2.  $6 > 2$ .

4 is less than 9.  $4 < 9$ .

5 is equal to 5.  $5 = 5$ .

Tutor may need to model the first example or take turns with the student as extra support.

SAVE SYNONYMS CHART IN STUDENT PROGRESS FOLDER FOR USE IN FUTURE ACTIVITIES.

## Building Trains

**Materials:** Connecting Cubes (1 bag) / 1 Red Number Cube (4-9)

**Purpose:** Student practices understanding and using the language of *more* and *less*.

### **PART I:**

Student rolls the Red Number Cube and builds a train representing that number. Then student rolls the Red Number Cube again and makes a second train. Place the two trains beside each other.

Ask the student:

**“How are the two trains different?”**

Accept any correct statements. If student does not use the words *more* or *less*, ask student,

**“Can you tell me how they are different, using the words *more* or *less*?”**

Repeat, rolling the Number Cube to make trains of different lengths until the student can confidently identify which has *more* and which has *less*.

### **PART II:**

Ask student to roll the Red Number Cube. Then ask student to build a train with *more* cubes and a train with *less* cubes than the number rolled.

Example for 5:

Ask,

**“Build a train that has *more* than five cubes.”**

**“Build a train that has *less* than five cubes.”**

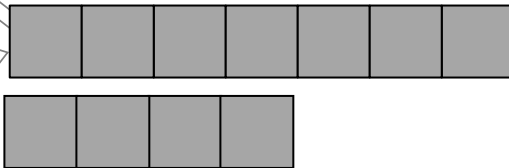

Ask student to use a sentence to say how each train relates to the number rolled.

Students says,

**"Seven is *more* than five. "**

**"Four is *less* than five."**

Repeat by asking student to roll additional numbers.

**NOTE:** *If student struggles to verbalize a sentence, they may write the sentence.*

HEART MATH TUTORING



## Let's Connect!

**Materials:** Let's Connect Packet for More or Less (*enclosed in Student Progress Folder*) / Word Problem Guide Card (*pink card on cart*) / Paper and pencil

**Purpose:** Student practices standards-aligned content to continue reinforcing and developing skills and concepts.

- 1) Together with student, complete one page (four squares) in the **Let's Connect** More or Less packet.
- 2) For any word problems, use the pink Word Problem Card (*found on the cart*) as a guide for how to talk about and work through the problems in a meaningful way.
- 3) Refer to the pink **Let's Connect** More or Less **Answer Key** (*found on the cart*) to check student work and answers.

## GOALS

*Student will be able to:*

1. Describe how to change one number into another number and how to make two groups the same.
2. Count forward from a given number.
3. Count back one or two from a given number.
4. Determine which quantity is *more* or *less*.

## ACTIVITIES

*The time required to complete each activity will vary from student to student. Allow student to move at their own pace. If more time is needed, lessons can be carried over to the next tutoring session.*

### **Roll and Add Game**

### **Give and Take**

### **Let's Connect**

## MATERIALS ENCLOSED

Number Path (1-30)

4 Blank Ten Frames

## MATERIALS TO GET

Connecting Cubes (2 bags,  
different colors)

2 Yellow Dot Cubes (1-6)

2 Yellow Number Cubes (1-6)

Paper and pencil

## IN PROGRESS FOLDER

Synonyms Chart (*if needed*)

Let's Connect Packet  
for More or Less

## WRAP-UP

- Compliment student for hard work and provide stickers as a reward.
- Discuss with student the lesson goals that were practiced today.
- Ask student two of the following questions on the way back to class:
  - What was hard about today?
  - What did you feel confident about?
  - Where did you see improvement?
  - What do you still need to practice?
  - How do you feel about your effort today?
- Encourage student to compare quantities at home.
- Record brief notes on progress log.

## Roll and Add Game

**Materials:** 2 Yellow Dot Cubes (1-6) / 2 Yellow Number Cubes (1-6) / Number Path (1-30) / Paper and pencil

**Purpose:** Student reviews relationships between numbers and practices *counting on* rather than *counting all* to add. (The goal is for students to add on to the original number without recounting from one.)

**NOTE:** When adding, it is typically easier to start with the larger number and add the smaller number to it. This will be particularly helpful for students in Levels 2 and 3 below.

Create a game board with pencil and paper as shown below.

2	3	4	5	6	7	8	9	10	11	12

The following levels increase in difficulty. Spend the most time playing the game in the level that is challenging, but not frustrating for student.

### **Level 1: Using Yellow Dot Cubes**

Ask student to roll 2 Yellow Dot Cubes and to add the number of dots together. Ask student to write their initials in the column that matches the sum.

Tutor and student should take turns doing this.

The first person to write their initials two times in one column is the winner.

Observe method student uses to add. If they must count all the dots on both cubes, challenge them to start with one number and count on, as follows:

- Identify the number of dots on the first cube. (If necessary to avoid forgetting the number, write it on a piece of paper.)
- Start from that number and count forward using the dots on the second cube to determine the total.

## **Level 2: Using one Number Cube and one Dot Cube**

Repeat the game, using 1 Yellow Number Cube and 1 Yellow Dot Cube.

Encourage student to start with the number on the Yellow Number Cube and to “count on” from that number using the dots on the Yellow Dot Cube.

## **Level 3: Using two Number Cubes**

Repeat the game, using 2 Yellow Number Cubes.

Without dots on the second cube to help student *count on*, they may need help keeping track of the units being added.

The Number Path, fingers, or Connecting Cubes are tools that may help. To keep track using the Number Path, student would need to pick one of the Number Cubes to be the starting quantity and to locate it on the Number Path. Then they would move forward the number of steps matching the number rolled on the other Number Cube. Help student understand that each step forward represents adding one unit, and the number you land on is the sum.

For further discussion, ask,

**“Does it matter which number is your starting point?”** *Student should know that the answer would be the same regardless of where they start.*

**“Which way makes you do more work?”** *Starting from the larger number requires less counting.*

## Give and Take

**Materials:** Connecting Cubes (2 bags, different colors) / Blank Ten Frame (4) / Paper and pencil

**Purpose:** Student reviews the relationships between numbers by changing one number to another and describing what was added or taken away.

### **PART I: Match Me**

Student and tutor each build a number of their choice between 1 and 10 by placing Connecting Cubes on their own blank Ten Frame. Players should hide their work while building (using an arm or folder).

Count to three, then tutor and student reveal the numbers they have built.

Ask student,

**“What number did you build? What number did I build?”**

**“What would you need to do to change your Ten Frame so that it matches mine?”**

Responses might include, “*add some more*” or “*take some away*”. Ask student to make a guess of *how many* they will have to add or take away to match your number.

Ask student to check their guess by adding or removing the Connecting Cubes they said are needed.

**“Try it and see.”**

- ***If student’s prediction for how many should be added/subtracted proves correct***, repeat activity 3 additional times. If student continues to be successful, repeat activity with student and tutor each building a number between 1 and 20 (use two blank Ten Frames for numbers 11 and above.)
- ***If student’s prediction is not correct***, allow student to continue adjusting Connecting Cubes until arriving at the matching number. Ask questions to prompt thinking as needed.

Example for 3 and 5:

Student and tutor build and reveal the following:

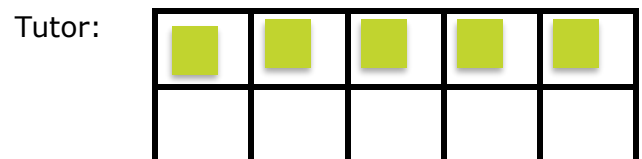
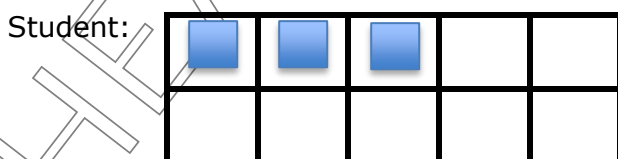

Tutor asks student,

**“What number did you build?” “3” “What number did I build?” “5”**

**“What would you need to do to change your Ten Frame so that it matches mine?”**  
*“Add 2 more.”*

**“Try it and see!”**

Repeat several times with numbers between 1 and 10 or 1 and 20 according to student’s ability to be successful.

## **PART II: Give and Take**

Tell student:

**“Now you will direct me to add or take away a specific number of cubes to change the Ten Frame to a new number.”**

**NOTE:** *This will move student beyond random guessing and checking, toward knowing number relationships.*

Change 3 to 5:

Say,

**“Put 3 cubes on the Ten Frame.”**

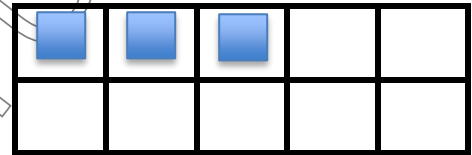

Collect the extra cubes not being used on the Ten Frame.

Ask student,

**“What would you tell me to do to change the Ten Frame to show 5?”**

The student might say, *“Add 2 cubes.”*

Add the cubes as student directs. Let the student check to see if the correct number is showing.

Change 5 to 2:

Ask student,

**“What would you tell me to do to change the Ten Frame to show 2?”**

The student might say, *“You need to take away 3 cubes.”*

Take away the cubes as student directs. Let the student check to see if the correct number is showing.

Repeat for the following examples:

Change 2 to 8

Change 8 to 6

Change 6 to 11

Change 11 to 15

Change 15 to 13

Change 13 to 18

## Let's Connect!

**Materials:** Let's Connect Packet for More or Less (*enclosed in Student Progress Folder*) / Word Problem Guide Card (*pink card on cart*) / Paper and pencil

**Purpose:** Student practices standards-aligned content to continue reinforcing and developing skills and concepts.

- 1) Together with student, complete one page (four squares) in the **Let's Connect** More or Less packet.
- 2) For any word problems, use the pink Word Problem Card (*found on the cart*) as a guide for how to talk about and work through the problems in a meaningful way.
- 3) Refer to the pink **Let's Connect** More or Less **Answer Key** (*found on the cart*) to check student work and answers.

## GOALS

*Student will be able to:*

1. Describe *how many more* and *how many less* one quantity is than another.
2. Count forward from a given number.
3. Count back one or two from a given number.
4. Determine which quantity is *more* or *less*.

## ACTIVITIES

*The time required to complete each activity will vary from student to student. Allow student to move at their own pace. If more time is needed, lessons can be carried over to the next tutoring session.*

**Intro to How Many More/How Many Less**

**Number Path with Stacks**

**Let's Connect**

## MATERIALS ENCLOSED

Number Path (1-10)

Number Path (1-30)

## MATERIALS TO GET

Connecting Cubes (3 bags,  
different colors)

Paper and pencil

## IN PROGRESS FOLDER

Synonyms Chart

Let's Connect Packet  
for More or Less

## WRAP-UP

- Compliment student for hard work and provide stickers as a reward.
- Discuss with student the lesson goals that were practiced today.
- Ask student two of the following questions on the way back to class:
  - What was hard about today?
  - What did you feel confident about?
  - Where did you see improvement?
  - What do you still need to practice?
  - How do you feel about your effort today?
- Encourage student to compare quantities at home.
- Record brief notes on progress log.



## Intro to How Many More/How Many Less

**Materials:** Connecting Cubes (2 bags, 2 colors) / Number Path (1-10) / Synonyms Chart (*Saved in Student's Progress Folder*) / Paper and pencil

**Purpose:** Student practices comparing numbers and describing *how many more* or *how many less* one number is compared to another.

Tell student,

**"So far we have been answering the questions 'which is more' and 'which is less.' Now we are going to be answering the questions 'how many more' and 'how many less.' Let's look at the image below."**

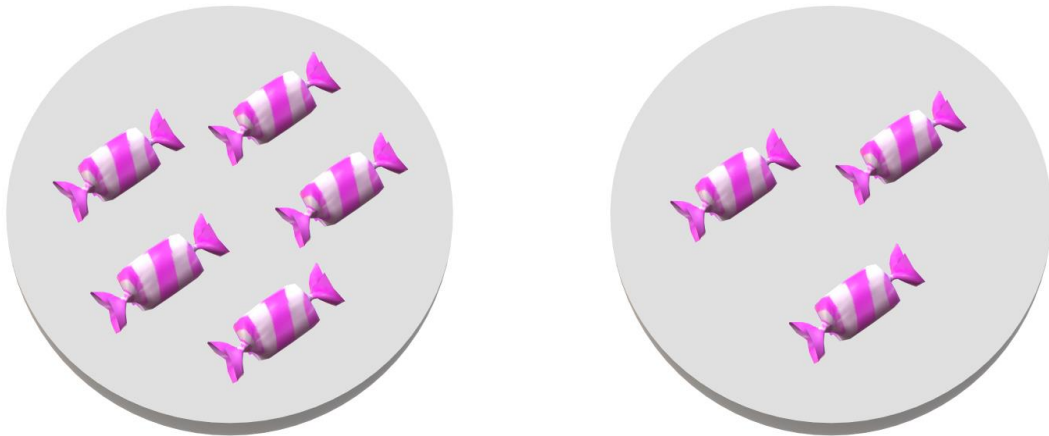

**"The plate on the left has some candy and the plate on the right has some as well. Which one has more?"**

Once student has determined that the left plate has more, say,

**"Great! We know that the left plate has more. That was the easy part! Now we want to know *how many more* pieces of candy are on it."**

If student struggles to figure this out, use additional questions:

**"Another way to ask this, is how many extras does the left plate have?"**

**"How many candies would we need to eat so that the left plate matched the right plate?"**

**"How many candies would we need to add to the right plate to make it the same as the left?"**

NOTE: If the student still struggles, use cubes to represent the pieces of candy and ask the student the above questions again.

Once the student has determined that the left plate has two more, say,

**“Let’s practice the four questions again: – (allowing the student to answer)**

- 1) Which has more?** *The left!*
- 2) How many more?** *Two.*
- 3) Which has less?** *The right!*
- 4) How many less?”** *Two.*

Use the bottom half of the Synonyms Chart (How Many More/How Many Less) to write down all expressions that student equates with the phrases “How Many More” and “How Many Less.”

*(If student started this notebook at Lesson 1, the Synonyms Chart will already be in their folder.)*

How Many More	How Many Less
<i>--How many extras --How many does the smaller pile need to be the same as the larger pile</i>	<i>--How many to catch up --How would you make the larger pile the same as the smaller pile</i>

PLEASE RETURN 20 SAME COLOR CONNECTING CUBES TO EACH BAG.

SAVE SYNONYMS CHART (HOW MANY MORE/LESS) IN STUDENT PROGRESS FOLDER FOR USE IN FUTURE ACTIVITIES.

## Number Path With Stacks- How Many More/Less

**Materials:** Connecting Cubes (3 bags, different colors) / Number Path (1-10) / Completed Synonyms Chart (*Saved in Student's Progress Folder*) / Paper and pencil

**Purpose:** Student practices comparing numbers and describing *how many more* or *how many less* one number is compared to another.

### **PART I:**

Place the Number Path (1-10) on the table.

To help save time, please assist student to make stacks of cubes for each number and to put the stacks behind the corresponding number on the Number Path as shown below.

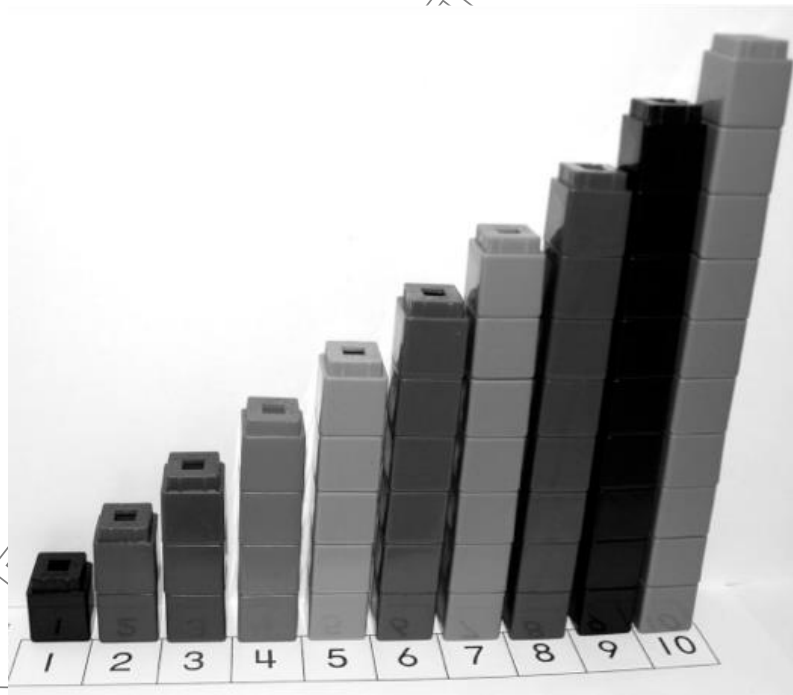

Tell student,

**"In the last activity, you learned about determining *difference* using the questions "how many more?" and "how many less?" Now we will continue learning how to use those questions by comparing stacks. Let's look at the row of stacks we made together."**

Ask student to look at the stacks and to describe what they see. Compliment student on their answer. If student struggles ask,

**“What is different about each stack?”**

Emphasize the number relationships by saying,

**“Going up, each tower has one more than the tower before it. Going down, each tower has one less.”**

Choose two stacks, take them from the Number Path and place them side-by-side on the table.

Ask student,

**“Which stack has more? Can you tell me how many more cubes are in the taller stack?”**

If student struggles, refer to the questions on the Synonyms Chart.

**“How many extras are in the taller stack?”**

**“How many would you need to break off to make the stacks the same size?”**

**“How many does the shorter stack need to catch up to the taller stack?”**

Put the stacks back where they belong along the Number Path and choose two different stacks to take away and compare.

Repeat activity several times, asking *how many more* and referencing Synonyms Chart if student continues to struggle.

## **PART II:**

**“Now we are going to figure out how many less one stack is than the other.”**

Choose two stacks, take them from the Number Path and place them side-by-side on the table.

**“Which stack has less? Can you tell me how many less cubes are the in the shorter stack?”**

If student struggles, refer to the questions on the Synonyms Chart.

**“How many are missing in the shorter stack?”**

**“What would you do to make the tall stack the same as the short stack?”**

Put the stacks back where they belong along the Number Path and choose two different stacks to take away and compare.

Repeat activity several times, asking *how many less* and referencing Synonyms Chart if student continues to struggle.

**PART III:**

As student continues comparing stacks, ask them,

**“What do you notice about the number of *extra* cubes and the number of steps between the numbers?”** (*They are the same.*)

Allow student to discover this relationship as they continue comparing stacks.

If student is able to compare stacks and determine *how many more/less*, show them how to describe the difference between two stacks with complete sentences. Offer two possibilities for *more* and for *less*, using the language modeled below.

Examples for *how many more*:

**“8 is 3 more than 5 OR 8 is more than 5 by 3.”**

**“6 is 2 more than 4 OR 6 is more than 4 by 2.”**

Examples for *how many less*:

**“7 is 3 less than 10 OR 7 is less than 10 by 3.”**

**“5 is 2 less than 7 OR 5 is less than 7 by 2.”**

Ask student to compare stacks using complete sentences on their own. If student struggles, help student visualize sentence structure by writing the sentence on paper, leaving blanks for the student complete.

4 is \_\_\_\_\_ than 6 by \_\_\_\_\_ OR, 8 is \_\_\_\_\_ than 5

PLEASE RETURN 20 SAME COLOR CONNECTING CUBES TO EACH BAG.

## Let's Connect!

**Materials:** Let's Connect Packet for More or Less (*enclosed in Student Progress Folder*) / Word Problem Guide Card (*pink card on cart*) / Paper and pencil

**Purpose:** Student practices standards-aligned content to continue reinforcing and developing skills and concepts.

- 1) Together with student, complete one page (four squares) in the **Let's Connect** More or Less packet.
- 2) For any word problems, use the pink Word Problem Card (*found on the cart*) as a guide for how to talk about and work through the problems in a meaningful way.
- 3) Refer to the pink **Let's Connect** More or Less **Answer Key** (*found on the cart*) to check student work and answers.

### GOALS

*Student will be able to:*

1. Determine which quantity is *more* or *less*.
2. Describe *how many more* and *how many less* one quantity is than another.
3. Understand the language of *more* and *less* and use it correctly in spoken and written sentences.
4. Describe how to change one number to another number and how to make two groups the same.
5. Count forward from a given number.
6. Count back one or two from a given number.

### ACTIVITIES

*The time required to complete each activity will vary from student to student. Allow student to move at their own pace. If more time is needed, lessons can be carried over to the next tutoring session.*

#### **Mystery Trains**

#### **Number Cards**

#### **Stories about More or Less**

#### **Let's Connect**

### MATERIALS ENCLOSED

Number Cards (1-20)

### MATERIALS TO GET

Connecting Cubes (4 bags, 3 the same color, 1 a different color)

Paper and pencil

### IN PROGRESS FOLDER

Let's Connect Packet  
for More or Less

### WRAP-UP

- Compliment student for hard work and provide stickers as a reward.
- Discuss with student the lesson goals that were practiced today.
- Ask student two of the following questions on the way back to class:
  - What was hard about today?
  - What did you feel confident about?
  - Where did you see improvement?
  - What do you still need to practice?
  - How do you feel about your effort today?
- Encourage student to compare quantities at home.
- Record brief notes on progress log.

## Mystery Trains

**Materials:** Connecting Cubes (3 bags of one color, 1 bag of a different color) / Paper

**Purpose:** Student explores relationships between numbers by counting *on* rather than counting *all* to find the length of a second train.

Say to student,

**“Today we are going to play a game called Mystery Trains. You have to figure out the length of mystery trains that I will make.”**

Example 1:

Tell student,

**“Please make a train of one color that is 7 cubes long while I make the mystery trains.”**

While student is building their train, tutor should make trains of 11, 5 and 16 cubes with a second color and hide them under a sheet of paper.

Tell student,

**“I’m going to show you one of the mystery trains. Can you figure out how many cubes are in the mystery train *without* counting every cube in the train? You can use the train you made to help you measure.”**

Move the train of 11 cubes out from under the paper. Place it beside the train of 7 and ask,

**“How many cubes are in the mystery train?”**

Some students will count forward by ones from the train of 7 to determine that there are 11. (This process is called “counting on”. The goal is ultimately for students to “count on” from the original number without recounting from one.)

Others will count every cube in the train of 11 to figure out its length. If student counts every cube in the train of 11 to determine its length, allow them to do so and acknowledge their correct answer. Then, help student see relationships between numbers by saying,

**“I want to see if you can figure out the length of the mystery train without having to count every cube. Let’s start with the train you made to help us measure.”**



**“How many cubes are in the train you made?”** (Student answers 7.)

**“Since you know there are 7 cubes in the train you made, how many cubes do you think are in the mystery train?”**

If student does not use the length of the first train (7) to determine the length of the second (11), encourage further reflection by laying the train of 7 on the Number Path and putting the train of 11 beside it. Ask student to think again about where they could start counting to find the total. If student cannot figure it out, model the process of “counting on” from 7 to get 11.

Continue activity by showing student the other two mystery trains and asking the same questions.

Example 2:

Repeat the activity, asking student to make a train of 9 cubes while tutor makes mystery trains of 13, 6 and 17.

## Number Cards

**Materials:** Connecting Cubes (2 bags of the same color) / Number Cards (1-20)

**Purpose:** Student practices changing one quantity to another and describing how to make two groups the same.

### PART I: Changing a Tower

Using only Number Cards 1-10, place cards face down on the table. Ask student to choose a card and make a tower of that height. Ask student to choose a second card and *change the tower* to match the number on the second card.

Allow student to use whatever method they need to change the cubes to the right number.

After student changes the tower, ask them,

**“What did you do to change the tower?”**

Notice the following:

- When adding, does student add on to the original number without recounting from one, or do they need to start counting again from the beginning? Ultimately, the goal is for student to add on to the original number without recounting from one, though it may take time to become comfortable with this.
- Is student able to keep track of the number of cubes they add or subtract? Encourage them to experiment with ways to keep track.

Repeat exercise with additional Number Cards.

### PART II: Numbers to 20

Use Number Cards 10 – 20 and repeat.

For added fun, keep track of correct answers as “points” and challenge student to earn 10 points.

## Stories About More and Less

**Materials:** Connecting Cubes (2 bags, different colors)

**Purpose:** Student practices using the language of *more* and *less* through stories.

Tell student:

**“Today we are going to make up stories about two groups that can be compared. First we will choose a situation for the story. Then we will determine the amounts (the numbers) we want to represent with our story. Finally, we will use cubes to model the story.”**

Help student choose one of the suggested situations below or to make up their own.

Apples and bananas  
Sharks and minnows  
Tigers and lions  
Boys and girls on the playground  
Ducks and chickens  
Pretzels and crackers

Using two colors of cubes, make up a story that requires comparing the two groups to find the difference. Using the words “more” or “less”, ask the student questions about the two groups in the story.

Example:

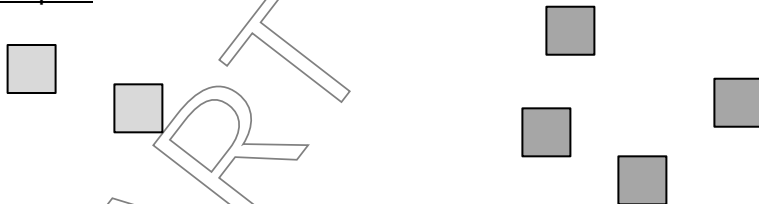

**“After students finished eating breakfast, there were 2 bananas (yellow cubes) and 4 apples (red cubes) on the table. What is the difference between the apples and bananas? How many more apples are there than bananas?”**

Ask student to do this several times, sometimes asking “how many more” and sometimes asking “how many less”.

## Let's Connect!

**Materials:** Let's Connect Packet for More or Less (*enclosed in Student Progress Folder*) / Word Problem Guide Card (*pink card on cart*) / Paper and pencil

**Purpose:** Student practices standards-aligned content to continue reinforcing and developing skills and concepts.

- 1) Together with student, complete one page (four squares) in the **Let's Connect** More or Less packet.
- 2) For any word problems, use the pink Word Problem Card (*found on the cart*) as a guide for how to talk about and work through the problems in a meaningful way.
- 3) Refer to the pink **Let's Connect** More or Less **Answer Key** (*found on the cart*) to check student work and answers.

## GOALS

*Student will be able to:*

1. Determine *how many more* and *how many less* one quantity is than another.
2. Count forward from a given number.
3. Understand the language of *more* and *less* and use it correctly in spoken and written sentences.
4. Describe how to change one number to another number and how to make two groups the same.

## ACTIVITIES

*The time required to complete each activity will vary from student to student. Allow student to move at their own pace. If more time is needed, lessons can be carried over to the next tutoring session.*

### **Mystery Trains Plus**

### **Building Trains of More or Less**

### **Dice War**

### **Let's Connect**

## MATERIALS ENCLOSED

Number Cards (1-3)

Number Path (1-30)

Building Trains Board

## MATERIALS TO GET

Connecting Cubes (3 bags of one color, 1 bag of a different color)

2 Red Number Cubes (4-9)

2 Yellow Number Cubes (1-6)

+/- Cube

Paper and pencil

## IN PROGRESS FOLDER

Let's Connect Packet  
for More or Less

## WRAP-UP

- Compliment student for hard work and provide stickers as a reward.
- Discuss with student the lesson goals that were practiced today.
- Ask student two of the following questions on the way back to class:
  - What was hard about today?
  - What did you feel confident about?
  - Where did you see improvement?
  - What do you still need to practice?
  - How do you feel about your effort today?
- Encourage student to compare quantities at home.
- Record brief notes on progress log.

**Materials:** Connecting Cubes (3 bags of one color, 1 bag of another color) / Paper / Completed Synonyms Chart (*Saved in Student's Progress Folder*)

**Purpose:** Student explores relationships between numbers by counting *on* rather than counting *all* to find the length of a second train.

Say to student,

**"Today we are going to play the game Mystery Trains again. You have to figure out the length of mystery trains that I will make and this time you will also tell the difference between the two trains."**

Example 1:

Tell student,

**"Please make a train of one color that is 4 cubes long while I make the mystery trains."**

While student is building their train, tutor should make trains of 7, 9, and 3 cubes with a second color and hide the trains under a sheet of paper.

Tell student,

**"I'm going to show you one of the mystery trains."**

Move the train of 7 cubes out from under the paper. Place it beside the train of 4 and ask,

**"How many cubes are in the mystery train? Can you figure it out *without* counting every cube in the train? You can use the train you made to help you measure."**

Some students will count forward by ones from the train of 4 to determine that there are 7. Others will count every cube in the train of 7 to figure out its length.

If student does not use the length of the first train (4) to determine the length of the second (7), encourage further reflection by laying the train of 4 on the Number Path and putting the train of 7 beside it. Ask student to think again about where they could start counting to find the total. If student cannot figure it out, model the process of "counting on" from 4 to get 7.

After student determines the length of the mystery train, ask,

**"What is the difference between the two trains?"**

If student doesn't know how to figure out the difference, rephrase by asking, **"How many extras are in the mystery train?"** or **"What could we do to make these trains the same?"** or **"How many does the shorter train need to catch up to the taller train?"**

Continue the activity by showing student the other two mystery trains and asking the same questions.

Example 2:

Repeat the activity, asking student to make a train of 5 cubes while tutor makes mystery trains of 4, 6, and 10.

HEART MATH TUTORING

## Building Trains of More and Less

**Materials:** Connecting Cubes (2 bags of the same color) / Building Trains Board / 1 Yellow Number Cube (1-6) / Number Cards (1-3) / +/- Cube

**Purpose:** Student practices using concepts of more and less to change numbers.

Tell student,

**“Today we are going to build trains of different lengths to practice the language and understanding of *more* and *less*. It is important to be able to talk about numbers using this language.”**

### **PART I: Student builds trains that are more and less than an original train.**

Ask student to roll the Yellow Number Cube and build a train of that length using Connecting Cubes. Place the train on the Building Trains Board.

Ask student to roll the + / - Cube. Based on the + / - Cube, ask student to make a train that is *more* or *less* than the original train and to place it on the Building Trains Board.

Then ask student to say *how many more* or *less* the new train is than the original train.

Roll the + / - cube several times to provide practice building larger trains (“+”) and smaller trains (“-”).

#### Example:

Student rolls a 4 and builds a train on the Building Trains Board.

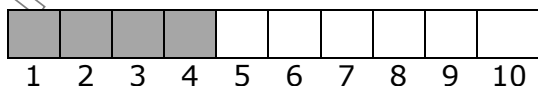

Then student rolls the + / - Cube and it lands on “-”. Student can build any train that is less than 4, and chooses to build a train of 3 (pictured below).

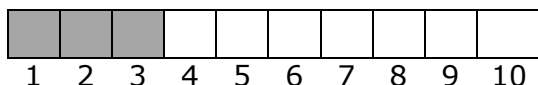

When asked *how many less* the new train is compared to the original train student may say,

*“The train of 3 is 1 less than the train of 4.” or “3 is less than 4 by 1.”*



Student rolls the +/- Cube again, landing on "+" and can build any train that is more than the original train (4). Student chooses to build a train of 6 (pictured below).



When asked *how many more* the new train is compared to the original train, student may say,

*"The train of 6 is 2 more than the train of 4." Or "6 is more than 4 by 2."*

### **PART II: Student builds trains that are a specific number of cubes more or less than the original train**

Ask student to roll the Yellow Number Cube, build a train of that length, and place it on the Building Trains Board.

Pick one of the Number Cards 1, 2, and 3 and ask student to roll the +/- Cube.

Based on the Number Card and the + / - Cube, ask student to build a second train that is that many more or less than the original train and to tell the length of the new train.

#### Example:

Student rolls a 4 and builds the train on the board.

Tutor picks the Number Card 3 and student rolls the + / - Cube landing on +.

Tutor would say,

**"Build a train that is 3 more than your train."**

**Note:** Help student see that the Building Trains Board can serve as a guide for building the second train. The new train should have 3 "extra" cubes.

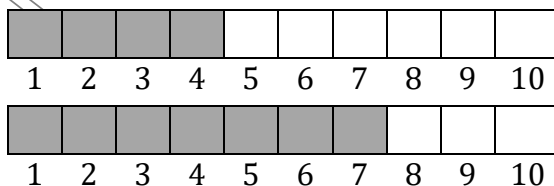

When student finishes the task of creating a new train, ask them to tell you the length of the new train. Model *counting on* by counting forward by ones from the train of 4 to determine the length of the new train (start at 4, and count "5, 6, 7").

Repeat activity several times to provide practice with both *more* and *less*.

## Dice War

**Materials:** Connecting Cubes (1 bag) / 2 Red Number Cubes (4-9) / 2 Yellow Number Cubes (1-6) / Number Cards (1-20) / Paper and pencil

**Purpose:** Student practices comparing two numbers and begins to answer *how many more* and *how many less*.

Each player gets 1 Red Number Cube.

**“Today we are going to play a game where the person who rolls the larger number gets a point. You will also get a point after each roll if you can tell me the difference between the numbers!”**

Each player rolls their Red Number Cube. After each roll, ask student,

**“Which number is larger? What is the difference between the numbers? How many more (or less) would I need to equal your number?”**

If student is unable to figure out the difference in their head or on their fingers, suggest using either the Number Path or Connecting Cubes to figure out the difference.

Example:

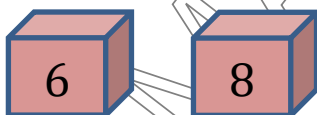

*You would need two more to match my number.*

Award a “point” to the person who rolls the larger number each time and a “point” to the student if they can correctly tell the difference between the two numbers. Play until one player wins 10 points.

At the end of the game, ask the student,

**“Who won? How many points did you win by?”**

Play again, decreasing or increasing difficulty if needed. To decrease the difficulty, use Yellow Number Cubes (1 – 6). To increase the difficulty, play by drawing Number Cards between 10 and 20.

## Let's Connect!

**Materials:** Let's Connect Packet for More or Less (*enclosed in Student Progress Folder*) / Word Problem Guide Card (*pink card on cart*) / Paper and pencil

**Purpose:** Student practices standards-aligned content to continue reinforcing and developing skills and concepts.

- 1) Together with student, complete one page (four squares) in the **Let's Connect** More or Less packet.
- 2) For any word problems, use the pink Word Problem Card (*found on the cart*) as a guide for how to talk about and work through the problems in a meaningful way.
- 3) Refer to the pink **Let's Connect** More or Less **Answer Key** (*found on the cart*) to check student work and answers.



### GOALS

*Student will be able to:*

1. Determine *how many more* and *how many less* one quantity is than another.
2. Use the language of *more* and *less* correctly in spoken and written sentences.
3. Describe how to change one number to another number.

### ACTIVITIES

*The time required to complete each activity will vary from student to student. Allow student to move at their own pace. If more time is needed, lessons can be carried over to the next tutoring session.*

#### **Bird Watching**

#### **Comparing Colors in a Handful**

#### **Let's Connect**

### MATERIALS ENCLOSED

Number Cards (1-20)

### MATERIALS TO GET

Connecting Cubes (2 bags,  
different colors)

Paper and Pencil

### IN PROGRESS FOLDER

Let's Connect Packet  
for More or Less

### WRAP-UP

- Compliment student for hard work and provide stickers as a reward.
- Discuss with student the lesson goals that were practiced today.
- Ask student two of the following questions on the way back to class:
  - What was hard about today?
  - What did you feel confident about?
  - Where did you see improvement?
  - What do you still need to practice?
  - How do you feel about your effort today?
- Encourage student to compare quantities at home.
- Record brief notes on progress log.

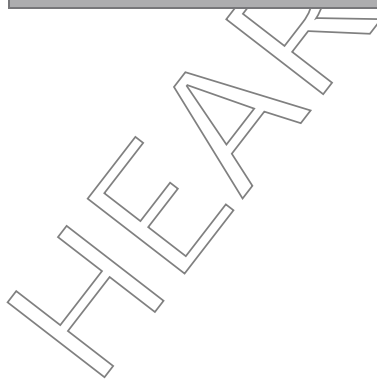

## Bird Watching

**Materials:** Connecting Cubes (1 bag) / Number Cards (1-20) / Paper and Pencil

**Purpose:** Student practices changing one number to another and telling how many were added or taken away.

Say to student,

**"We are going to play a game that involves birds getting on and off of a telephone wire. The cubes will represent birds. On our paper you can draw the telephone wire. It needs to be long enough to hold up to 20 cubes.**

**To play the game I will tell you how many birds are on the wire at each time of the day. You will add or take away cubes to show that number and tell me how many birds got on or off the wire.**

**If you change the number correctly, you get a point. If you can tell me how many birds got on or off the wire, you get another point. We'll play the game until you get 12 points."**

Give student paper and cubes. Allow them to draw telephone poles with a wire across them.

### **Bird Watching Level I**

Tutor finds the number cards 4, 7 and 5 and 9 and has them ready to use as labels as they read the story below and ask the related questions.

**"At 8:00AM, you look outside and see 4 birds on the telephone wire.**

*Tutor puts the 4 card down as a label and waits for student to add the cubes.*

**At 9:00AM, you check again and see 7 birds on the telephone wire.**

*Tutor puts the 7 card down as a label and waits for student to change the cubes.*

**Did more birds land on the wire or did some fly away? How many got on/off?**

**At 10:00AM, you look out the window and see 5 birds on the telephone wire.**

*Tutor puts 5 card down as a label and waits for student to change the cubes.*

**Did more birds land on the wire or did some fly away? How many got on/off?**

**At 11:00AM you look out the window and see 9 birds on the telephone wire.**  
*Tutor puts the 9 card down as a label and waits for student to change the cubes.*

**Did more birds land on the wire or did some fly away? How many got on/off?**

Allow student to use whatever method they need to change the cubes to the right number.

Notice the following:

- When adding, does student add on to the original number without recounting, or do they need to start counting again from the beginning? Ultimately, the goal is for student to add on to the original number without recounting, though it may take time to become comfortable with this.
- Is student able to keep track of the number of cubes they add or subtract? Encourage them to experiment with ways to keep track.

**NOTE:** *If student struggles with Bird Watching Level I, provide additional practice with numbers between 1 and 10. If student is successful with above activity move on to Bird Watching Level II.*

### **Bird Watching Level II**

Using the format above, tutor changes the number of birds on the wire from 12 to 16 to 13 to 17.

**NOTE:** *If student struggles with Bird Watching Level II, provide additional practice with numbers between 11 and 20.*

## Comparing Colors in a Handful

**Materials:** Connecting Cubes (2 bags, different colors) / Completed Synonyms Chart (Saved in Student's Progress Folder) / Paper and pencil

**Purpose:** Student practices determining *how many more* or *how many less* one group has than another.

### PART I: Less / How Many Less

Using the two bags of cubes, put ten cubes of each color in one bag.

Ask student to reach in and take out as many cubes as they would like and place them on the table, sorting the cubes by color and leaving them in piles. For added fun, student may choose to pretend the cubes are other objects (candy, toys, hair ribbons, etc.)

Ask student,

**"Which color has less cubes? How many less?"**

If the student has trouble answering the question, ask them if they can think about ways to organize the cubes to figure out the difference.

Some possibilities include:

- Make two trains by snapping together all the cubes of the same color, as shown below. Place the trains side by side to compare them. He/she may want to break off the "extras" to make the trains the same length before counting them.

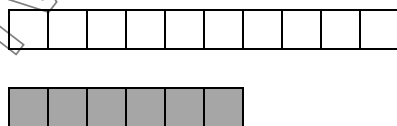

- Pair one of each color and see the leftovers.

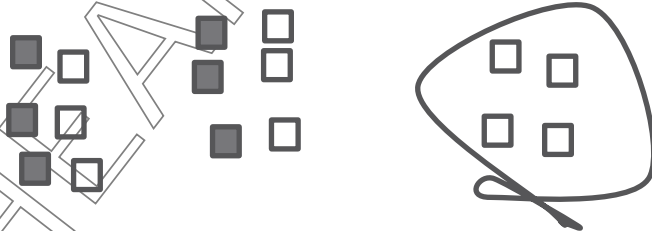

*I paired each gray with a white cube and I have 4 white left over.*

- Recognize one number within the other.

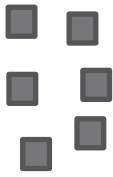

*I counted 6 grey.*



*I counted 6 white and I have 4 white left over.*



Repeat for several different handfuls.

### **PART II: More / How Many More**

Repeat the activity, using a different handful of cubes, but this time ask the student which pile has more cubes.

Ask student,

**“Which color has more cubes? How many more cubes are that color?”**

Repeat for several different handfuls.

(See options above for ways to organize cubes that can help student find the difference.)

### **PART III: Using Sentences with How Many More/Less?**

When student feels comfortable figuring out *how many more* or *less*, demonstrate to them how to make complete sentences to compare the number of cubes, as shown below:

**7 cubes are 5 more than 2 -OR- 7 cubes are more than 2 by 5.**  
**4 cubes are 5 less than 9 -OR- 4 cubes are less than 9 by 5.**

Ask student to try saying complete sentences on their own. Write on paper and say aloud to help student practice the sentence structure. Provide encouragement and help as needed.

**NOTE:** *If student struggles to verbalize a sentence, they may write the sentence instead.*

PLEASE RETURN 20 SAME COLOR CONNECTING CUBES TO EACH BAG.



## Let's Connect!

**Materials:** Let's Connect Packet for More or Less (*enclosed in Student Progress Folder*) / Word Problem Guide Card (*pink card on cart*) / Paper and pencil

**Purpose:** Student practices standards-aligned content to continue reinforcing and developing skills and concepts.

- 1) Together with student, complete one page (four squares) in the **Let's Connect** More or Less packet.
- 2) For any word problems, use the pink Word Problem Card (*found on the cart*) as a guide for how to talk about and work through the problems in a meaningful way.
- 3) Refer to the pink **Let's Connect** More or Less **Answer Key** (*found on the cart*) to check student work and answers.



### GOALS

*Student will be able to:*

1. Determine *how many more* and *how many less* one quantity is than another.
2. Understand the language of *more* and *less* and use it correctly in spoken and written sentences and with symbols ( $>$ ,  $<$ ).
3. Describe how to change one number to another number and how to make two groups the same.

### ACTIVITIES

*The time required to complete each activity will vary from student to student. Allow student to move at their own pace. If more time is needed, lessons can be carried over to the next tutoring session.*

**Cereal Game for How Many More or Less**

**The School Bus Ride**

**War - How Many More or Less**

**Let's Connect**

***After this lesson is completed, check in with the Program Coordinator to determine if student is ready to move on to the next Concept Notebook.***

### MATERIALS ENCLOSED

Number Cards (1-20)

Number Path (1-30)

### MATERIALS TO GET

Connecting Cubes (2 bags, different colors)

Deck of Cards

2 Red bowls

+/- Cube

Paper and pencil

### IN PROGRESS FOLDER

Let's Connect Packet  
for More or Less

### WRAP-UP

- Compliment student for hard work and provide stickers as a reward.
- Discuss with student the lesson goals that were practiced today.
- Ask student two of the following questions on the way back to class:
  - What was hard about today?
  - What did you feel confident about?
  - Where did you see improvement?
  - What do you still need to practice?
  - How do you feel about your effort today?
- Encourage student to compare quantities at home.
- Record brief notes on progress log.

## Cereal Game for How Many More or Less

**Materials:** Connecting Cubes (2 bags, different colors) / 2 Red bowls / +/- Cube / Number Cards (1-20) / Completed Synonyms Chart (*Saved in Student's Progress Folder*) / Paper and Pencil

**Purpose:** Student practices describing the difference between two quantities in terms of *how many more* and *how many less*.

Each player starts with 1 Red bowl and 1 bag of Connecting Cubes broken apart.

Each player grabs a random number of Connecting Cubes ("cereal") out of their bag and puts them into their bowl ("cereal bowl"). Each player counts their "cereal" and selects the Number Card of the corresponding quantity to place beside the bowls as a label.

One player rolls the +/- Cube.

- If the cube lands on "+", the player with *more* cereal must answer the question, **"How many more pieces of cereal do I have?"** They get a point after answering with a complete sentence. (For example, "9 is 5 more than 4." Or, "I have 5 more.")
- If the cube lands on "-", the player with *less* cereal must answer the question, **"How many less pieces of cereal do I have?"** They get a point after answering with a complete sentence. (For example, "I have 3 less." Or "5 is 3 less than 8")

If needed, write the sentence structure as a model and visual aid: "5 is \_\_\_ less than 8" -OR- "5 is less than 8 by \_\_\_".

If student struggles to answer *how many more* or *how many less*:

- Remind student that *how many more/less* is asking for the *difference* between the bowls of cereal. Refer to questions in Synonyms Chart to help with comparisons.
- Suggest making trains or organizing the piles in a way that helps them determine the difference.

Play the game until one player has 5 points. After each few turns ask student,

**"Who has more points? How many more? Who has less points? How many less?"**

Repeat if student needs additional practice.

Ultimately, the goal is for students to answer the questions "how many more" and "how many less" without the help of rephrasing the questions.

PLEASE RETURN 20 SAME COLOR CONNECTING CUBES TO EACH BAG.

## The School Bus Ride

**Materials:** Connecting Cubes (1 bag) / Number Cards (1-20) / Paper and Pencil

**Purpose:** Student practices changing one number to another and telling how many were added or taken away.

Say to student,

**"We are going to play a game that involves students getting on and off of a school bus. The cubes will represent students. This piece of paper will be the bus. You can draw a picture of the school bus if you like or we can just leave it blank. The bus needs to be big enough to hold up to 20 cubes."**

**To play the game I will tell you how many students are on the bus after it leaves each stop. You will add or take away cubes to show that number and tell me how many students got on or got off the bus.**

**If you change the number correctly, you get a point. If you can tell me how many students got on or off the bus, you get another point. We'll play the game until you get 12 points."**

Give student paper and cubes. Allow them to draw a bus or to leave it blank.

### **Bus Ride Level I**

Tutor finds the number cards 5, 8 and 6 and 10 and has them ready to use as labels as they read the story below and asks the related questions.

**"After the bus leaves the first stop, there are 5 students on the bus.**

*Tutor puts the 5 card down as a label and waits for student to add the cubes.*

**After the bus leaves the second stop, there are 8 students on the bus.**

*Tutor puts the 8 card down as a label and waits for student to change the cubes.*

**Did students get on or get off the bus? How many got on/off?**

**After the bus leaves the next stop, there are 6 students on the bus.**

*Tutor puts 6 card down as a label and waits for student to change the cubes.*

**Did students get on or get off the bus? How many got on/off?**

**After the bus leaves the final stop, there are 10 students on the bus.**

*Tutor puts the 10 card down as a label and waits for student to change the cubes.*

**Did students get on or off the bus? How many got on/off?"**

Allow student to use whatever method they need to change the cubes to the right number.

Notice the following:

- When adding, does student add on to the original number without recounting, or do they need to start counting again from the beginning? Ultimately, the goal is for student to add on to the original number without recounting, though it may take time to become comfortable with this.
- Is student able to keep track of the number of cubes they add or subtract? Encourage them to experiment with ways to keep track.

**NOTE:** *If student struggles with Bus Ride Level I, provide additional practice with numbers between 1 and 10. If student is successful with above activity move on to Bus Ride Level II.*

### **Bus Ride Level II**

Using the format above, tutor changes the number of students on the bus from 11 to 15 to 12 to 19.

**NOTE:** *If student struggles with Bus Ride Level II, provide additional practice with numbers between 11 and 20.*

## War – How Many More or Less

**Materials:** Connecting Cubes (1 bag) / Deck of Cards

**Purpose:** Student practices understanding and using the language of *how many more* and *how many less*.

### **PART I: War for Less**

Remove the Jack, Queen and King or let them equal 11, 12 and 13. The Ace represents 1.

Split the cards evenly between two players.

Both players turn over their top cards. The player with the lower number takes both cards after saying a complete sentence to describe *how many less* their card is than the other.

Example:

**8 is 2 less than 10.**

**1 is 4 less than 5.** (The Ace represents 1.)

**7 is less than 9 by 2.**

If the two players turn over the same card, both must do the following to “beat the tie”:

- Place three cards face down and then one card face up.
- The player with the lower card takes all the cards after using a sentence to describe the difference.

Continue until there are no more cards to turn over. The player with the most cards wins. Ask student, **“Who won? By how many?”**

### **PART II: War for More**

Same rules as above but the player with the higher number wins after saying a complete sentence to describe *how many more* their card is than the other.

Example:

**10 is 2 more than 8.**

**5 is 4 more than 1.** (The Ace represents 1.)

**8 is more than 5 by 3.**

**NOTE:** If student struggles to verbalize a sentence, they may write the sentence. If needed, tutor can also write an example sentence on paper to demonstrate the structure of the language of more/less.

## Let's Connect!

**Materials:** Let's Connect Packet for More or Less (*enclosed in Student Progress Folder*) / Word Problem Guide Card (*pink card on cart*) / Paper and pencil

**Purpose:** Student practices standards-aligned content to continue reinforcing and developing skills and concepts.

- 1) Together with student, complete one page (four squares) in the **Let's Connect** More or Less packet.
- 2) For any word problems, use the pink Word Problem Card (*found on the cart*) as a guide for how to talk about and work through the problems in a meaningful way.
- 3) Refer to the pink **Let's Connect** More or Less **Answer Key** (*found on the cart*) to check student work and answers.



HEART  
MATH TUTORING

Lessons and Activities for

# Combinations to 10

*Volunteer Check-Out Materials*

The materials in this notebook are to be used only in conjunction with Heart Math Tutoring. Please contact the administrator of this program before reproducing any materials found in this notebook.



# COMBINATIONS TO 10

## Concept Overview

**IMPORTANT NOTE:** Student will do ALL of the lessons in this notebook for one "Focus Number" at a time, learning all of the "combinations" (two part pairs) for that number before having the coordinator assess and determine the next "Focus Number." The Program Coordinator will let tutors know the appropriate starting Focus Number for each student.

### CONCEPT GOALS

*For every number up to 10, student will be able to:*

1. Find and describe all the ways a number can be broken into two parts.
2. Determine the missing part of numbers without counting, when the other part is known.
3. Describe the parts of numbers using symbols +, -, and =.
4. Use knowledge of combinations to solve word problems.

### END OF PROGRAM ASSESSMENT

*Knowing how students will be assessed can help guide instruction.*

**Example 1: Dot Arrangements** – Student will be shown a variety of Dot Arrangement Cards and asked to determine the total number of dots on each by pointing out recognizable groups and combining them.

**Example 2: Hiding Assessment** – The assessor will hide a specific quantity of Connecting Cubes under his/her hand. Then he/she will reveal part of the total and ask student to tell how many are still hiding. Student must be able to tell the number "quickly," without counting.

### KEY POINTS

*The information below may assist you in helping your student.*

- When students can break up any number to ten and put the parts together again with ease, they will be able to work flexibly and powerfully with larger numbers.
- Internalizing combinations of numbers to 10 is critical to building a strong foundation and may take several months, requiring frequent review.
- Subitizing – recognizing small groups of objects without counting each one. This is a fundamental skill in the development of number sense.

**GOALS**

*For his/her Focus Number, student will be able to:*

1. Find and describe all the ways the Focus Number can be broken into two parts.
2. Describe the parts of the Focus Number using the symbols +, -, and =.
3. Use knowledge of combinations to solve word problems.

**ACTIVITIES**

*The time required to complete each activity will vary from student to student. Allow student to move at his/her own pace. If more time is needed, lessons can be carried over to the next tutoring session.*

**On/Off Game****Dot Arrangement Flash Cards – My Focus Number and Below****Let's Connect****MATERIALS ENCLOSED**

None

**MATERIALS TO GET**

Base Ten Cubes (1 bag)

Dot Arrangement Flash Cards

Paper (2) and pencil

Let's Connect Packet  
for Combinations to 10**WRAP-UP**

- Compliment student for hard work and provide stickers as a reward.
- Discuss with student the lesson goals that were practiced today.
- Ask student two of the following questions on the way back to class:
  - What was hard about today?
  - What did you feel confident about?
  - Where did you see improvement?
  - What do you still need to practice?
  - How do you feel about your effort today?
- Encourage student to tell someone at home about the doubles strategies used today.
- Record brief notes on progress log.

## On / Off Game

**Materials:** Base Ten Cubes (1 bag) / Paper (2) and pencil

**Purpose:** Student explores the ways the focus number can be broken into two parts.

Create a recording sheet on one sheet of paper as shown below and fold the second sheet into quarters (see image below).

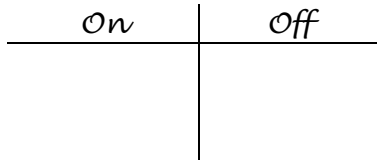

Ask student to count out Base Ten cubes equal to his/her Focus Number.

Ask student to hold the cubes over the folded second sheet of paper and to let them drop on the paper. Some cubes will stay on the paper and some will fall off.

Ask student to write the number of cubes "on" versus "off" the paper on the recording sheet.

Ask student to repeat 10 or more times, continuing to record. Discuss any patterns the student sees.

**NOTE:** Watch to see if student is able to predict how many cubes are off the paper after identifying the number on, OR whether he/she needs to count each cube to determine the number off. If student is counting, challenge him/her to predict the second number.

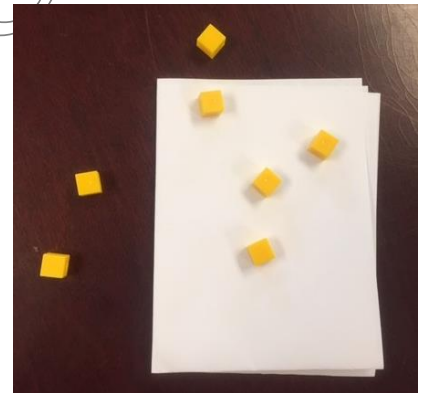

### **Make the Task a Game**

Say to student,

**"We are going to drop these cubes 7 more times on the folded paper. Each of us will pick a combination and we will see whose combination comes up the most. What combination do you think will come up the most?"**

After student chooses a combination, tutor chooses a different one. The person whose combination comes up the most is the winner!

### **Play What If**

Ask student,

**"What if "x" cubes landed on the paper. How many cubes would be off?"**

Repeat for a variety of combinations. Have student model the combination with cubes on the folded paper to support and verify the predictions.

## Play True or False

Ask student to determine if the following equations for his/her focus number are true or false. Encourage student to use the recording sheet for reference if needed.

### **For Focus Number 6**

$$5 + 1 = 1 + 5 \quad 3 + 3 = 4 + 2 \quad 3 + 4 = 6 \quad 6 = 0 + 6 \quad 6 = 5 + 1$$

### **For Focus Number 7**

$$7 + 1 = 7 \quad 6 + 1 = 5 + 2 \quad 3 + 4 = 4 + 3 \quad 7 = 7 + 0 \quad 7 = 2 + 5$$

### **For Focus Number 8**

$$6 + 2 = 3 + 5 \quad 5 + 3 = 7 \quad 8 = 8 + 0 \quad 1 + 7 = 7 + 1 \quad 8 = 4 + 4$$

### **For Focus Number 9**

$$9 = 6 + 3 \quad 4 + 5 = 7 + 2 \quad 1 + 8 = 0 + 9 \quad 6 + 4 = 9 \quad 9 = 8 + 1$$

### **For Focus Number 10**

$$8 + 2 = 6 + 4 \quad 10 = 7 + 3 \quad 1 + 8 = 10 \quad 0 + 10 = 9 + 1 \quad 10 = 5 + 5$$

HEART MATH TUTORING

## Dot Arrangement Flash Cards – My Focus Number and Below

**Materials:** Dot Arrangement Flash Cards

**Purpose:** Student practices recognizing groups within numbers for their Focus Number and below.

**NOTE:** Dot Arrangement Flash Cards are printed by color as shown below:

- Orange = Focus #5 and below
- Yellow = Focus #6
- Blue = Focus #7
- Green = Focus #8
- Pink = Focus #9
- White = Focus #10

Choose the Dot Arrangement Flash Cards for the current focus number your student is working on, **as well as any numbers lower than your student's focus number.** Mix the cards!

Tell student,

**"We are going to practice figuring out how many shapes we see without counting by ones or twos. The best way to do this is to practice breaking big numbers into groups we can see right away and then combining those groups."**

Show student a Dot Arrangement Flash Card. Ask student to identify the total shown on the card by looking for groups and combining them.

To prompt student to use and combine recognizable groups, ask,

**"What groups do you see?"**  
**"How many is that altogether?"**

Or, if student begins by telling the total, ask,

**"How did you see that?" "What groups did you see?"**

Example for 9 Card:

The student might see groups of 4 and 5 and say, " $4 + 5 = 9$ ."



Or a student might tell you, "I see 3 and 6." Ask them, "How many is that altogether?"



Another student might say they see 9, and when you ask them what groups they saw to get 9, they tell you, "I saw  $4 + 3 + 2$ ."



**NOTE:** If student counts by ones or twos to find the total, ask them, **“Is there another way you can see that?”** \*\*Counting by twos is still considered "counting" and is not the same skill as recognizing groups and adding them together.\*\* Encourage student to identify larger groups emphasizing the combinations for their Focus Number.

Together with student, go through one-by-one the remainder of the Dot Arrangement Flash Cards (for the student’s current Focus Number, and the numbers below). Ensure the cards are mixed so it’s not all the same Focus Number total in a row. Ask student to identify the total shown on the cards by looking for groups and combining them. Please ensure the student is identifying the parts they saw.

\*Students do not need to identify all the ways groups could be seen on the card. Once they’ve identified the groups they saw, move to the next card.

### **Optional – Timed Game**

For students who enjoy a race, time student to see how long it takes to identify the number of dots/shapes on each card for their focus number, using known combinations, for all cards. Write down the time, then play again to see if they can beat the first time.

HEART MATH TUTORING

## Let's Connect!

**Materials:** Let's Connect Packet for Combinations to 10 (*enclosed in Student Progress Folder*) / Word Problem Guide Card (*pink card on cart*) / Paper and pencil

**Purpose:** Student practices standards-aligned content to continue reinforcing and developing skills and concepts.

- 1) Together with student, complete half of a page (two squares) in the **Let's Connect** Combinations to 10 packet.
- 2) For any word problems, use the pink Word Problem Card (*found on the cart*) as a guide for how to talk about and work through the problems in a meaningful way.
- 3) Refer to the blue **Let's Connect** Combinations to 10 **Answer Key** (*found on the cart*) to check student work and answers.

### GOALS

*For his/her Focus Number, student will be able to:*

1. Find and describe all the ways the Focus Number can be broken into two parts.
2. Determine the missing part of the Focus Number without counting, when the other part is known.
3. Describe the parts of the Focus Number using the symbols +, -, and =.
4. Use knowledge of combinations to solve word problems.

### ACTIVITIES

*The time required to complete each activity will vary from student to student. Allow student to move at his/her own pace. If more time is needed, lessons can be carried over to the next tutoring session.*

**Combinations Reference Sheet Side 1**

**Combinations Reference Sheet Side 2**

**Drawing Arrangements**

**Let's Connect**

### MATERIALS ENCLOSED

None

### MATERIALS TO GET

Connecting Cubes (3 bags of one color, 1 bag of a different color)

Base Ten Cubes (1 bag)

Combinations Reference Sheet

Drawing Arrangements Recording Sheet

Crayons – 2 different colors

Paper and pencil

Let's Connect Packet for Combinations to 10

### WRAP-UP

- Compliment student for hard work and provide stickers as a reward.
- Discuss with student the lesson goals that were practiced today.
- Ask student two of the following questions on the way back to class:
  - What was hard about today?
  - What did you feel confident about?
  - Where did you see improvement?
  - What do you still need to practice?
  - How do you feel about your effort today?
- Encourage student to practice "tricky" combinations at home.
- Record brief notes on progress log.



## Combinations Reference Sheet Side 1



**Materials:** Connecting Cubes (3 bags of one color, 1 bag of a different color) / Combinations Reference Sheet / Crayons - 2 different colors / Paper and pencil

**Purpose:** Student practices identifying and visualizing combinations for his/her Focus Number.

### PART I: Making Combination Trains

Using the grid and a pencil, create outlines for student's Focus Number as shown below:

Focus Number 6, draw 4 outlines  
Focus Number 7, draw 4 outlines

Focus Number 8, draw 5 outlines  
Focus Number 9, draw 5 outlines  
Focus Number 10, draw 6 outlines

Example for Focus Number 6:

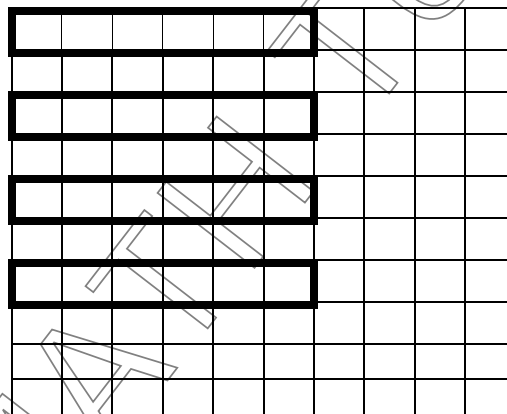

Tell student,

**“Let’s use two colors of cubes to help us find all the ways your Focus Number can be broken into two parts. I’ve made outlines for you to use for building the trains.”**

Ask student to create all the possible combinations for his/her Focus Number on the outlines.

Let student experiment with any method he/she chooses. If student struggles to get started, prompt student's thinking by asking questions such as:

**“If you start by putting 2 red cubes on the outline, how may yellow cubes would you need to fill it all the way up?”**

**NOTE:** *If student builds two different trains that show the same combination, such as 2 red cubes with 4 yellow cubes and 2 yellow cubes with 4 red cubes, use the opportunity to encourage student to compare the two trains and discover they are the same.*

After student has made all the trains, ask him/her to put them in order as shown in the example below.

Example for Focus Number 6:

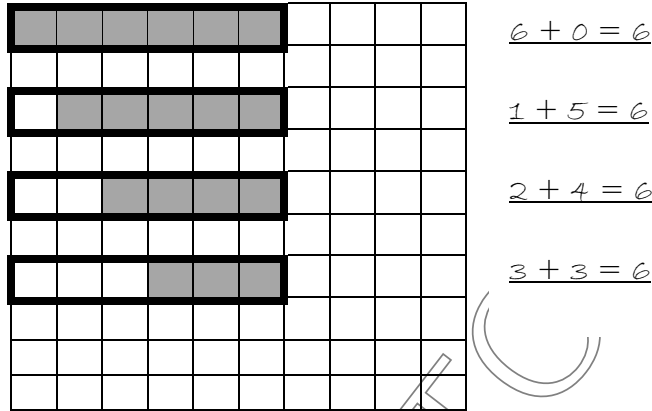

**PART II: Coloring the Grid and Writing Equations**

Ask student to move trains to the side of the paper and use crayons to color the grid to match each train.

For each train, ask student to write the matching equation beside each combination on the grid. After student has written the equations, tell student,

**“Let’s flip our paper over. What do you notice about the equations now? Is there a second way we can write each of these equations?”**

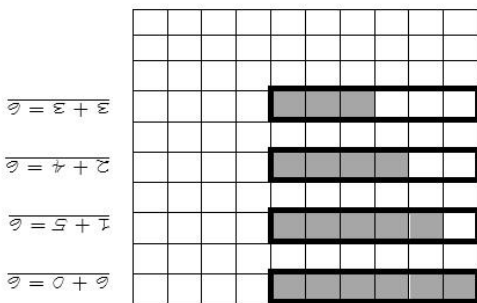

Help student recognize that the order of the two parts being added does not matter. For example, 1 + 5 is the same combination as 5 + 1.

**PART III: Snap It!**

Break one of the combination trains and hide one of the “parts” behind your back. Showing the remaining part of the train ask student,

**“How many cubes are hiding behind my back?”**

If student has trouble, have student use the coloring grid for reference and check using the cubes.

Rebuild the train and repeat for all of the combination trains.

*KEEP THE REFERENCE SHEET IN PROGRESS FOLDER FOR FUTURE ACTIVITIES.*

## Combinations Reference Sheet Side 2



**Materials:** Connecting Cubes (2 bags, different colors) / Combinations Reference Sheet (*In Progress Folder*) / Paper and pencil

**Purpose:** Student practices identifying and visualizing combinations for his/her Focus Number.

### Part I:

Using Combinations Reference Sheet Side 1, have student pick one combination drawing and, on Side 2, fill in one of the diagrams that represents a fact family. Help student write the four equations that go with this fact family.

Example for Focus Number 6:

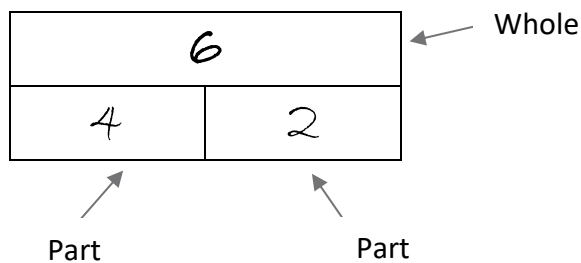

$$4 + 2 = 6$$

$$2 + 4 = 6$$

$$6 - 2 = 4$$

$$6 - 4 = 2$$

Ask student to repeat for all combinations of the Focus Number. A completed example for the Focus Number 6 is below. If needed, prompt student to check their work (using Side 1 or using cubes) to identify corrections needed rather than making the correction for them.

*If student struggles with creating the subtraction equations, tell them that when subtracting we start with the whole and take away one of the parts. Feel free to build the combination train needed.*

### Combinations Reference Sheet Side 2

Fact Families Focus # 6

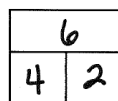

$$\begin{aligned} 4 + 2 &= 6 \\ 2 + 4 &= 6 \\ 6 - 2 &= 4 \\ 6 - 4 &= 2 \end{aligned}$$

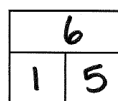

$$\begin{aligned} 1 + 5 &= 6 \\ 5 + 1 &= 6 \\ 6 - 1 &= 5 \\ 6 - 5 &= 1 \end{aligned}$$

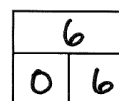

$$\begin{aligned} 6 + 0 &= 6 \\ 0 + 6 &= 6 \\ 6 - 0 &= 6 \\ 6 - 6 &= 0 \end{aligned}$$

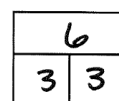

$$\begin{aligned} 3 + 3 &= 6 \\ 6 - 3 &= 3 \end{aligned}$$

Once student has completed the fact families, ask questions to ensure that the student understands the relationship between the addition and subtraction equations. For example,

**“If you know that 2 and 4 are parts that makes 6, then if I take away the 2 part from the 6, what part should be left?”**

**Part II:**

Without looking at the Combinations Reference Sheet, have your student tell you the missing piece in each of the fact families below that correspond to their focus number.

Focus #6

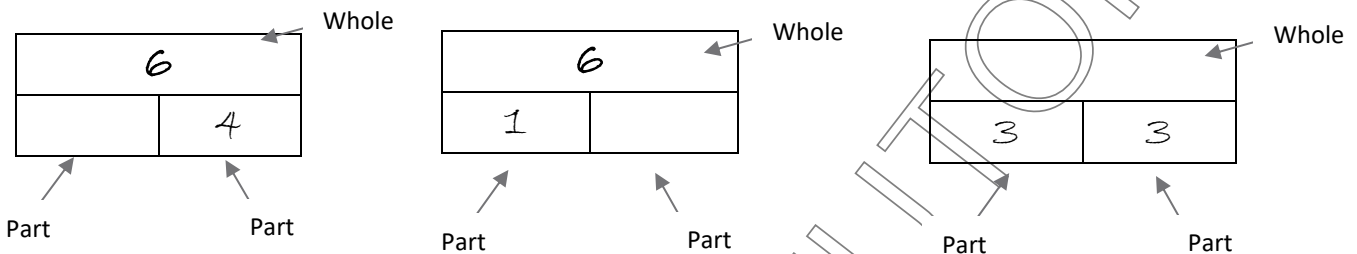

Focus #7

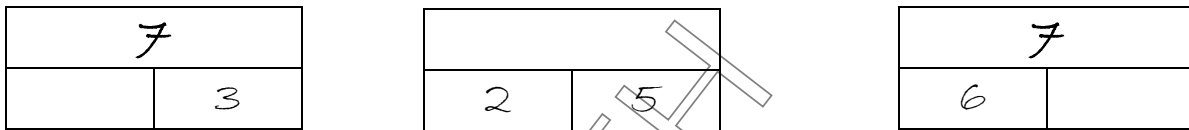

Focus #8

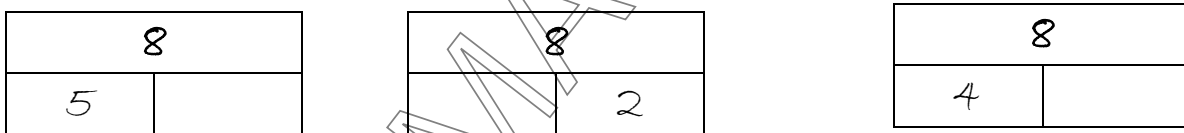

Focus #9

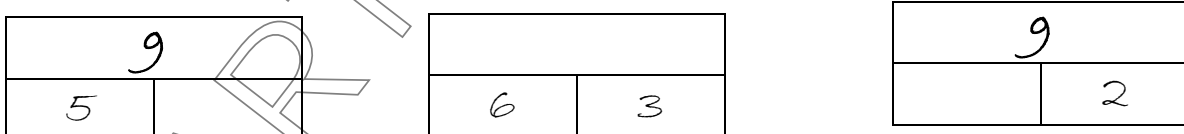

Focus #10

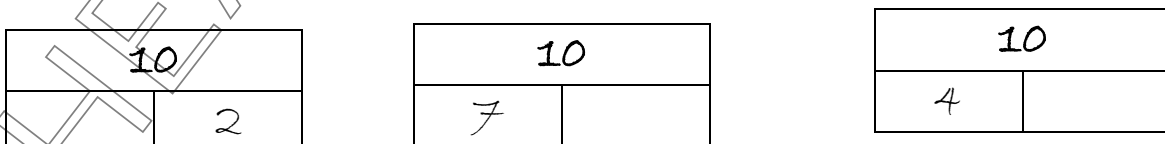

## Drawing Arrangements

**Materials:** Base Ten Cubes (1 bag) / Drawing Arrangements Recording Sheet / Pencil

**Purpose:** Student practices seeing groups of numbers within a specific number.

Ask student to count out Base Ten Cubes equal to their Focus Number. Tell student,

**“We are going to practice figuring out different ways we can break apart our Focus Number into two groups that we can see right away. Let’s organize the cubes into a design that shows the two groups you see that helps you know how many there are without having to count by ones or twos.**

**Once you’ve put the cubes in the design, then we will draw the same design in pencil on the sheet.”**

Ask student to circle the recognizable groups and write the combination equation under the drawing. Complete three designs for student’s Focus Number.

Example for Focus Number 7:

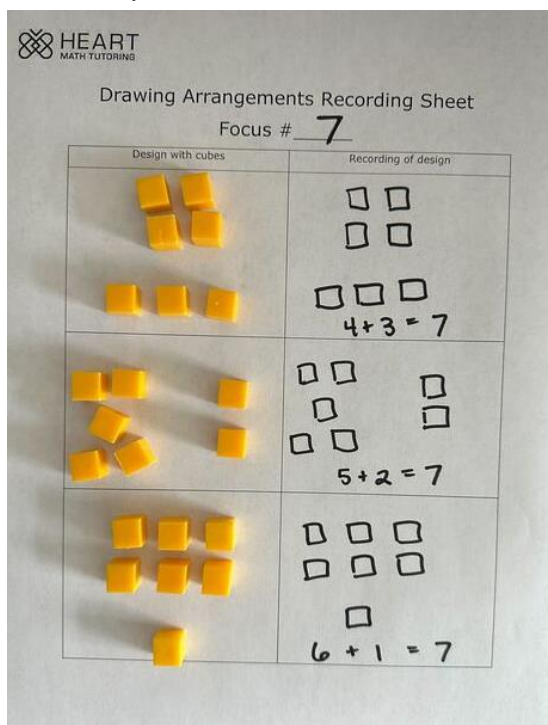

If student struggles to make recognizable groups, use patterns you have seen on dice or playing cards to help them make recognizable cube arrangements for the Focus Number. You can also refer back to the Combinations Reference sheet from the last lesson if needed.

Additional examples for each Focus Number are below:

Focus #6  
Examples:

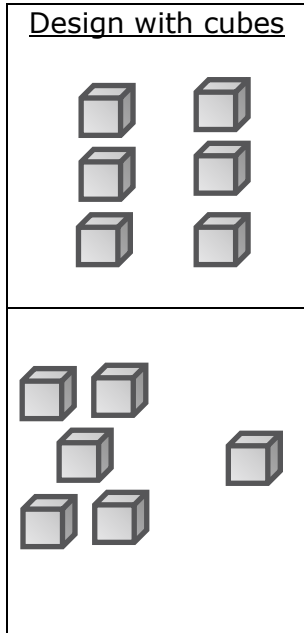

Focus #8  
Examples:

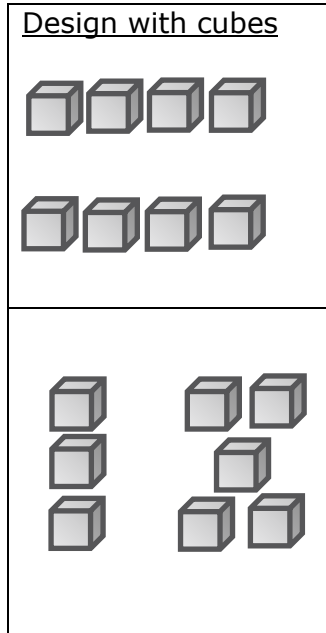

Focus #9  
Examples:

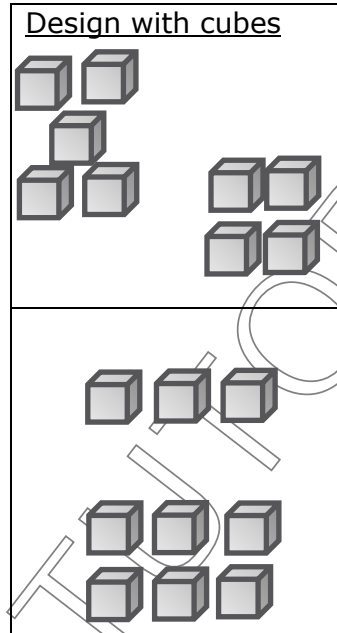

Focus #10  
Examples:

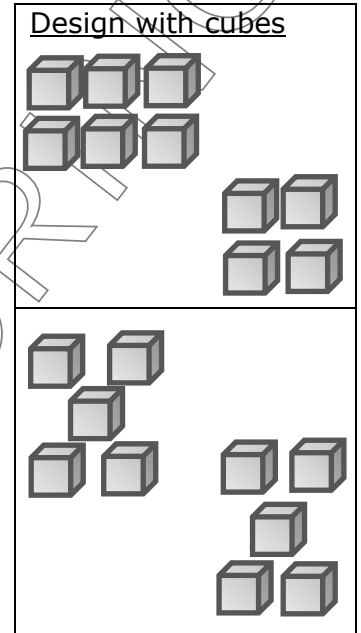

SAVE DRAWING ARRANGEMENTS RECORDING SHEET IN STUDENT PROGRESS FOLDER FOR USE IN FUTURE ACTIVITIES.

HEART MATH

## Let's Connect!

**Materials:** Let's Connect Packet for Combinations to 10 (*enclosed in Student Progress Folder*) / Word Problem Guide Card (*pink card on cart*) / Paper and pencil

**Purpose:** Student practices standards-aligned content to continue reinforcing and developing skills and concepts.

- 1) Together with student, complete half of a page (two squares) in the **Let's Connect** Combinations to 10 packet.
- 2) For any word problems, use the pink Word Problem Card (*found on the cart*) as a guide for how to talk about and work through the problems in a meaningful way.
- 3) Refer to the blue **Let's Connect** Combinations to 10 **Answer Key** (*found on the cart*) to check student work and answers.

### GOALS

*For his/her Focus Number, student will be able to:*

1. Find and describe all the ways the Focus Number can be broken into two parts.
2. Determine the missing part of the Focus Number without counting, when the other part is known.
3. Describe the parts of the Focus Number using the symbols  $+$ ,  $-$ , and  $=$ .
4. Use knowledge of combinations to solve word problems.

### ACTIVITIES

*The time required to complete each activity will vary from student to student. Allow student to move at his/her own pace. If more time is needed, lessons can be carried over to the next tutoring session.*

**Ten Frame**

**Name the Missing Part**

**Let's Connect**

### MATERIALS ENCLOSED

Blank Ten Frame

### MATERIALS TO GET

Connecting Cubes (2 bags,  
different colors)

1 Red bowl

Paper and pencil

### IN PROGRESS FOLDER

Completed Combinations  
Reference Sheet for Current Focus  
Number

Let's Connect Packet  
for Combinations to 10

### WRAP-UP

- Compliment student for hard work and provide stickers as a reward.
- Discuss with student the lesson goals that were practiced today.
- Ask student two of the following questions on the way back to class:
  - What was hard about today?
  - What did you feel confident about?
  - Where did you see improvement?
  - What do you still need to practice?
  - How do you feel about your effort today?
- Encourage student to practice "tricky" combinations at home.
- Record brief notes on progress log.



## Ten Frame

**Materials:** Connecting Cubes (1 bag) / Blank Ten Frame

**Purpose:** Student practices visualizing and describing the Focus Number in relation to 5 and 10.

Tell student,

**“Ten is the most important number in our number system, so it is helpful for us to think about numbers as they relate to 10. Five is also an important number because it is halfway to the number 10.”**

**The Ten Frame can help us see numbers in relation to 5 and 10. The *standard* way to fill a Ten Frame is to fill the top row first, starting at the left. When the top row is full, the bottom row can be filled, starting at the left.”**

Ask student to place cubes on the Ten Frame for his/her Focus Number.

Example for 6:

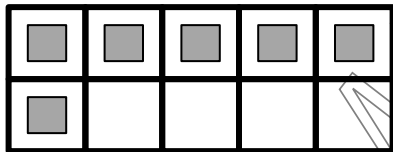

Example for 8:

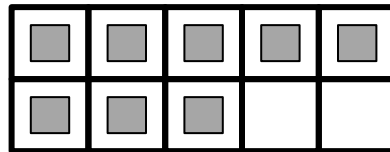

Then ask,

**“What does this number look like on the ten frame?” “How many are on the top, and how many are on the bottom?”**

**“How many more is this number than 5?”**

**“How many more do you need to have 10?”**

Help student see that his/her fingers can also be used to visualize numbers in relation to 5 and 10. Hold up as many fingers as are in the Focus Number, then ask,

**“How many fingers more than 5 are showing?”**

**“How many fingers (of 10) are not showing?”**

## Name the Missing Part

**Materials:** Connecting Cubes (1 bag) / 1 Red bowl / Completed Combinations Reference Sheet for Current Focus Number (*Saved in Student's Progress Folder*) / Paper and pencil

**Purpose:** Student practices naming the missing part of the Focus Number when one part is known.

**NOTE:** When working with combinations, naming the missing part (subtraction) is much more difficult for students than naming the sum of two known quantities. A student who has truly internalized a combination should be able to identify the missing part within three seconds and without counting. This often requires much practice!

### Part I:

Tell student,

**"Today we are going to use your Focus Number to play a game called *Name the Missing Part*. I will hide cubes under the table and you will tell me how many cubes are underneath as quickly as you can!"**

Ask student to fill the bowl with the number of Connecting Cubes equal to the Focus Number.

Hide the bowl under the table, out of student's sight. Take some cubes out of the bowl and place them on the table for student to see.

Ask,

**"How many are still in the bowl?"**

Allow student to check his/her answer by counting cubes in the bowl if needed.

Return all cubes to the bowl and make sure student knows that the bowl once again contains the number of cubes equal to the Focus Number.

Repeat several times by hiding the bowl and placing a different number of cubes on the table.

If student struggles, tell student the following, substituting his/her own focus number.

**"Let's see if your Combinations Reference Sheet with fact families can help us with this game. If we know the total in the bowl is (8) and I show you 2, how many are still in the bowl? Which fact family equation helps you most?"**

Allow student to discuss. He/she may think of  $8 - 2 = 6$  or  $2 + 6 = 8$ .

Part II:

Tell student,

**“When you are naming the missing part, we can also represent that as an equation with one of the parts missing. Look at the following equations for your focus number and tell me what is missing.”**

**For Focus Number 6**

$6 = \underline{\quad} + 2$        $6 = \underline{\quad} + 3$        $\underline{\quad} + 5 = 6$        $6 - 4 = \underline{\quad}$

**For Focus Number 7**

$7 = \underline{\quad} + 3$        $7 = \underline{\quad} + 1$        $\underline{\quad} + 5 = 7$        $7 - 4 = \underline{\quad}$

**For Focus Number 8**

$8 = 6 + \underline{\quad}$        $5 + \underline{\quad} = 8$        $\underline{\quad} + 7 = 8$        $8 - 3 = \underline{\quad}$

**For Focus Number 9**

$\underline{\quad} + 3 = 9$        $6 + \underline{\quad} = 9$        $9 = \underline{\quad} + 4$        $9 - 5 = \underline{\quad}$

**For Focus Number 10**

$7 + \underline{\quad} = 10$        $\underline{\quad} + 2 = 10$        $10 = \underline{\quad} + 5$        $10 - 4 = \underline{\quad}$

Tell student,

**“Now we will look at our Combinations Reference Sheet Side 1 and star the combinations that were tricky.”**

Help student recognize which combinations he/she knew within three seconds and which ones were more challenging.

**Making the Activity a Game**

Reverse roles by letting the student hide the cubes under the table. Then, without looking in the bowl, student should place some cubes on the table and ask you to identify the amount still in the bowl.

Tell student that sometimes you will answer correctly but sometimes you will answer incorrectly. If you answer incorrectly and your student catches you, he/she gets a point. If you answer incorrectly and he/she doesn't catch you, you get a point. The first person to get five points is the winner.

## Let's Connect!

**Materials:** Let's Connect Packet for Combinations to 10 (*enclosed in Student Progress Folder*) / Word Problem Guide Card (*pink card on cart*) / Paper and pencil

**Purpose:** Student practices standards-aligned content to continue reinforcing and developing skills and concepts.

- 1) Together with student, complete half of a page (two squares) in the **Let's Connect** Combinations to 10 packet.
- 2) For any word problems, use the pink Word Problem Card (*found on the cart*) as a guide for how to talk about and work through the problems in a meaningful way.
- 3) Refer to the blue **Let's Connect** Combinations to 10 **Answer Key** (*found on the cart*) to check student work and answers.

**GOALS**

*For his/her Focus Number, student will be able to:*

1. Find and describe all the ways the Focus Number can be broken into two parts.
2. Determine the missing part of the Focus Number without counting, when the other part is known.
3. Describe the parts of the Focus Number using the symbols  $+$ , and  $=$ .
4. Use knowledge of combinations to solve word problems.

**ACTIVITIES**

*The time required to complete each activity will vary from student to student. Allow student to move at his/her own pace. If more time is needed, lessons can be carried over to the next tutoring session.*

**Domino Fact Families****Finding Combos Card Game****Let's Connect****MATERIALS ENCLOSED**

Domino Cards

**MATERIALS TO GET**Connecting Cubes (2 bags,  
different colors)

Deck of Cards

Paper and pencil

**IN PROGRESS FOLDER**Let's Connect Packet  
for Combinations to 10**WRAP-UP**

- Compliment student for hard work and provide stickers as a reward.
- Discuss with student the lesson goals that were practiced today.
- Ask student two of the following questions on the way back to class:
  - What was hard about today?
  - What did you feel confident about?
  - Where did you see improvement?
  - What do you still need to practice?
  - How do you feel about your effort today?
- Encourage student to practice "tricky" combinations at home.
- Record brief notes on progress log.

## Domino Fact Families

**Materials:** Domino Cards / Paper and pencil

**Purpose:** Student gains familiarity with the parts of the Focus Number.

### PART I:

Ask student to find Domino Cards with dots that add up to the Focus Number. Ensure the student is determining the number of dots by recognizing groups rather than counting by ones or twos.

Example for Focus Number 7:

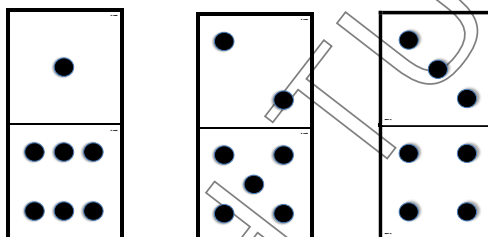

### PART II:

Ask student to draw the fact families on paper and to say the four equations that match each of the different dominos.

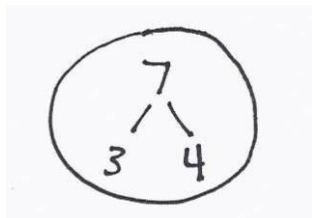

$$\begin{aligned} 3 + 4 &= 7 \\ 4 + 3 &= 7 \\ 7 - 4 &= 3 \\ 7 - 3 &= 4 \end{aligned}$$

### PART III:

Ask student to put the Domino Cards in order so that the number of dots on the top half increases by one. Ask student if he/she sees a pattern. (*When the dots on the top half increase by one, the dots on the bottom half decrease by one.*)

### PART IV:

Turn the Domino Cards face down.

One by one, pick up a Domino Card and show student **only** the top or bottom half of the card. Ask student to name the number on the hidden side. Again, ensure the student is determining the number of dots by recognizing groups rather than counting by ones or twos.

## Finding Combos Card Game

**Materials:** Deck of Cards / Paper and pencil

**Purpose:** Student practices finding combinations for the Focus Number.

Remove from the deck all numbers higher than student's Focus Number, keeping the focus number in the deck.

Split the cards evenly between tutor and student.

### **PART I:**

Ask student to spread all of his/her cards face up on the table. Ask student to find all of the combinations that add up to the Focus Number.

Ask student to place each pair in separate piles face down.

Tutor then does the same thing with his/her cards. Ask student to be sure the tutor is making the right combinations.

The person who finds the most combinations is the winner.

### **PART II:**

Turn the top card in each pair face up and leave the other card face down. Ask student to tell which card is "hiding" in each pair.

Pick up the cards as each pair is completed until the table is clear.

For added fun, time how long it takes for student to tell which card is "hiding" for all of the pairs.

### **PART III:**

Choose three pairs and help student write equations that demonstrate the written form of naming the hidden card. (E.g. If 2 is the card showing and the focus number is 6, student would write  $2 + \_ = 6$ )

**NOTE:** This will help prepare the student for higher levels of math (e.g., algebra) and is an important way to begin thinking abstractly about known and unknown quantities.

## Let's Connect!

**Materials:** Let's Connect Packet for Combinations to 10 (*enclosed in Student Progress Folder*) / Word Problem Guide Card (*pink card on cart*) / Paper and pencil

**Purpose:** Student practices standards-aligned content to continue reinforcing and developing skills and concepts.

- 1) Together with student, complete half of a page (two squares) in the **Let's Connect** Combinations to 10 packet.
- 2) For any word problems, use the pink Word Problem Card (*found on the cart*) as a guide for how to talk about and work through the problems in a meaningful way.
- 3) Refer to the blue **Let's Connect** Combinations to 10 **Answer Key** (*found on the cart*) to check student work and answers.



### GOALS

*For his/her Focus Number, student will be able to:*

1. Find and describe all the ways the Focus Number can be broken into two parts.
2. Determine the missing part of the Focus Number without counting, when the other part is known.
3. Describe the parts of the Focus Number using the symbols  $+$ ,  $-$ , and  $=$ .
4. Use knowledge of combinations to solve word problems.

### ACTIVITIES

*The time required to complete each activity will vary from student to student. Allow student to move at his/her own pace. If more time is needed, lessons can be carried over to the next tutoring session.*

#### **Adding and Subtracting on the Ten Frame**

#### **Creating Story Problems with Cubes**

#### **Hiding Game**

#### **Let's Connect**

### MATERIALS ENCLOSED

Blank Ten Frame

### MATERIALS TO GET

Connecting Cubes (2 bags, different colors)

1 Number Cube

*Focus Number 5: Green*

*Focus Number 6-8: Yellow*

*Focus Number 9-10: Yellow or Red*

Paper and pencil

### IN PROGRESS FOLDER

Let's Connect Packet  
for Combinations to 10

### WRAP-UP

- Compliment student for hard work and provide stickers as a reward.
- Discuss with student the lesson goals that were practiced today.
- Ask student two of the following questions on the way back to class:
  - What was hard about today?
  - What did you feel confident about?
  - Where did you see improvement?
  - What do you still need to practice?
  - How do you feel about your effort today?
- Encourage student to practice "tricky" combinations at home.
- Record brief notes on progress log.

## Adding and Subtracting on the Ten Frame

**Materials:** Connecting Cubes (2 bags, different colors) / Blank Ten Frame / Paper and pencil  
 1 Number Cube:  
 Focus Number 5 - Green (0-4)  
 Focus Numbers 6, 7, or 8 - Yellow (1-6)  
 Focus Number 9 or 10 - Yellow (1-6) or Red (4-9)

**Purpose:** Student practices two types of subtraction - finding the missing part and taking cubes away.

### **PART I: Adding to Find the Missing Part**

Ask student to roll the Number Cube and to place that many Connecting Cubes on the Ten Frame. Then ask him/her to use cubes of a **different color** to add the number needed to make the Focus Number.

Ask him/her to write on paper the equation shown on the Ten Frame and to draw the corresponding fact family diagram.

#### Example for Focus Number 8:

Student rolls 3 and places 3 red cubes on the Ten Frame.

Student determines how many he/she needs to make 8 and places 5 yellow cubes on the Ten Frame to make 8.

Student writes and draws the following:

$$3 + 5 = 8$$

8	
3	5

Repeat the process several times by re-rolling the Number Cube.

### **PART II: Subtracting from the Focus Number**

Fill the blank Ten Frame with cubes equal to the Focus Number. Ask student to roll the Number Cube again and to take away that many cubes from his/her Focus Number. Write the equation that matches the action taken and to draw the corresponding fact family diagram.

Example for 8:

Student begins with 8 cubes on the ten frame. Student rolls a 6 and takes 6 cubes off the frame, leaving 2.

Student writes and draws the following:

$$8 - 6 = 2$$

8	
6	2

Repeat the process several times by re-rolling the Number Cube.

HEART MATH TUTORING

## Creating Story Problems with Cubes

**Materials:** Connecting Cubes (1 bag)

**Purpose:** Student practices relating combinations to real world situations.

Tell Student,

**“Today you are going to make up stories using combinations for your Focus Number. First you will choose a situation for your story. Next you will look at the equations you are trying to represent with your story. You can use cubes to model.”**

Ask student to pick one of the suggested situations below or to make up his/her own.

Fish in the ocean  
Tigers in a cage  
Children at the park  
Children on a bus  
Dinosaurs taking a walk  
Birds in a tree

Ask student to count out cubes of one color equal to the Focus Number and create story problems to represent the equations below for his/her Focus Number using the cubes as a model. See examples at the end of the activity if needed.

### Focus Number 6:

$$6 - 2 = \underline{\quad}$$

$$5 + 1 = \underline{\quad}$$

### Focus Number 7:

$$3 + 4 = \underline{\quad}$$

$$7 - 2 = \underline{\quad}$$

### Focus Number 8:

$$8 - 4 = \underline{\quad}$$

$$5 + 3 = \underline{\quad}$$

**Focus Number 9:**

$7 + 2 = \underline{\quad}$

$9 - 3 = \underline{\quad}$

**Focus Number 10:**

$10 - 3 = \underline{\quad}$

$6 + 4 = \underline{\quad}$

**Examples story problems:**

- There were 6 children on the bus then 2 got off at their stop. How many children are still on the bus?
- There were 3 Pterodactyls flying near the volcano and 4 more joined them. How many Pterodactyls are there now?
- There were 8 Robins in the tree and 4 flew away to look for worms. How many birds are still in the tree?
- There are 7 tigers in a cage and the zookeeper adds 2 more. How many tigers are in the cage now?
- There were 10 minnows in a pond and a fisherman caught 3 of them. How many minnows are left?

## Hiding Game

**Materials:** Connecting Cubes (1 bag)

**Purpose:** Student practices naming the missing part of the Focus Number when one part is known.

**NOTE:** The Hiding Game involves naming the missing part (subtraction) which is much more difficult for students than adding. The goal is for students to quickly "know" or be able to quickly reason to the answers.

Ask student to count out the number of cubes for the Focus Number.

Hide all of the cubes under your hand.

Pull out 2 cubes and leave them showing on the table.

Tell student,

**"The goal is for you to tell me what's hiding as quickly as you can without counting."**

**"How many are still hidden?"**

Repeat by showing different quantities of cubes until every possible combination has been tested.

Tips for helping students:

- If the quantity shown is large, it may be easier to think about the problem as addition. (If  $8 - 6$  is difficult, suggest thinking about  $6 + \underline{\quad} = 8$ )
- If the quantity shown is close to a double, it may be easier to think of the double and make an adjustment to find the answer. ( $8 - 4 = 4$ , so  $8 - 3$  must be 5)

## Let's Connect!

**Materials:** Let's Connect Packet for Combinations to 10 (*enclosed in Student Progress Folder*) / Word Problem Guide Card (*pink card on cart*) / Paper and pencil

**Purpose:** Student practices standards-aligned content to continue reinforcing and developing skills and concepts.

- 1) Together with student, complete half of a page (two squares) in the **Let's Connect** Combinations to 10 packet.
- 2) For any word problems, use the pink Word Problem Card (*found on the cart*) as a guide for how to talk about and work through the problems in a meaningful way.
- 3) Refer to the blue **Let's Connect** Combinations to 10 **Answer Key** (*found on the cart*) to check student work and answers.

### GOALS

1. Identify known combinations and discover new combinations using existing knowledge.

*For his/her Focus Number, student will be able to:*

2. Find and describe all the ways the Focus Number can be broken into two parts.
3. Determine the missing part of the Focus Number without counting, when the other part is known.
4. Describe the parts of the Focus Number using the symbols  $+$ ,  $-$ , and  $=$ .
5. Use knowledge of combinations to solve word problems.

### ACTIVITIES

*The time required to complete each activity will vary from student to student. Allow student to move at his/her own pace. If more time is needed, lessons can be carried over to the next tutoring session.*

**Doubles Plus One/Minus One** (*ONLY play on student's first time through notebook*)

**Domino War**

**Name the Missing Part – Review**

**Let's Connect**

***-For Focus Numbers 6-9, check with your Program Coordinator after this lesson to see if your student is ready to move to the next Focus Number, and then start over with Lesson 1.***

***-If your student is working on Focus Number 10 please continue to Lesson 7.***

**MATERIALS  
ENCLOSED**  
Domino Cards

**MATERIALS TO GET**  
Connecting Cubes (2 bags,  
different colors)

1 Red bowl

Paper and pencil

**IN PROGRESS  
FOLDER**

Let's Connect Packet  
for Combinations to 10

### WRAP-UP

- Compliment student for hard work and provide stickers as a reward.
- Discuss with student the lesson goals that were practiced today.
- Ask student two of the following questions on the way back to class:
  - What was hard about today?
  - What did you feel confident about?
  - Where did you see improvement?
  - What do you still need to practice?
  - How do you feel about your effort today?
- Encourage student to practice "tricky" combinations at home.
- Record brief notes on progress log.



## Doubles Plus One / Minus One

**Materials:** Connecting Cubes (2 bags, different colors) / Paper and pencil

**Purpose:** Student uses known doubles combinations to learn new combinations.

Tell student,

**“Let’s talk about the combinations you already know and see how you can use these to learn new combinations.”**

### **PART I: Doubles Plus One**

For each doubles combination student already knows, help him/her explore what happens when one is added to a number in that combination. (Examples of doubles combinations include  $2 + 2 = 4$ ,  $4 + 4 = 8$ ,  $5 + 5 = 10$ .)

Example for  $2 + 2 = 4$  :

Ask student to use two colors of connecting cubes to build a train that shows the doubles combination.



Ask student,

**“You know that  $2 + 2 = 4$ . What if we add one more cube?”** *There would be 5.*

Ask him/her to add a cube of matching color to one end of the train as shown below:



**“What combination is showing now?”**  $2 + 3 = 5$

Ask student to write the doubles equation and the new equation on paper.

$$2 + 2 = 4$$

$$2 + 3 = 5$$

Repeat for each doubles combination student already knows.

## **PART II: Doubles Minus One**

For each doubles combination student already knows, help him/her explore what happens when one is taken away from a number in that combination.

Example for  $3 + 3 = 6$ :

Ask student to use two colors to build a train that shows the doubles combination.



Ask student,

**"You know that  $3 + 3 = 6$ . What if we take away one cube?"** *There would be 5.*

Then ask him/her to take a cube away from one end of the train to make the new combination as shown below:



**"What combination is showing now?"**  $2 + 3 = 5$

Ask student to write the doubles equation and the new equation.

$$3 + 3 = 6$$

$$3 + 2 = 5$$

Repeat for each doubles combination student already knows.

## Domino War

**Materials:** Domino Cards

**Purpose:** Student practices recognizing combinations for multiple Focus Numbers and finding the difference between them.

Together with student, flip through the Domino Cards. For each Domino Card that is equal to or lower than the Focus Number, ask student to identify the total shown on the card without counting by ones. Ask student to sort and take out all Domino Cards showing numbers higher than the student's Focus Number.

Split the remaining cards evenly between the two players.

First, tutor and student each turn over a card and say the sum that is showing on their card.

Then, student tries to say the difference between the two cards while tutor counts slowly to 3.

If student says the answer before tutor gets to 3, he/she keeps both cards. If not, tutor keeps the cards.

Play continues until all of the cards are turned over. The person with the most Domino Cards is the winner.

## Name the Missing Part - Review

**Materials:** Connecting Cubes (2 bags, different colors) / 1 Red bowl / Paper and pencil

**Purpose:** Student practices naming the missing part of a number when one part is known.

Tell student,

**“Today we are going to use your Focus Number to review a game we learned in an earlier lesson, called *Name the Missing Part*. I will hide cubes under the table and you will tell me as quickly as you can without counting – how many cubes are underneath!”**

Ask student to fill the bowl with the number of Connecting Cubes equal to the Focus Number.

Hide the bowl under the table, out of student’s sight. Take some cubes out of the bowl and place them on the table for student to see.

Ask,

**“How many are still in the bowl?”**

Allow student to check his/her answer by counting cubes in the bowl if needed.

Return all cubes to the bowl and make sure student knows that the bowl once again contains the number of cubes equal to the Focus Number.

Repeat several times by hiding the bowl and placing a different number of cubes on the table.

### **Variation: Making the Activity a Game**

Reverse roles by letting the student hide the cubes under the table. Then, without looking in the bowl, student should place some cubes on the table and ask you to identify the amount still in the bowl.

Tell student that sometimes you will answer correctly but sometimes you will answer incorrectly. If you answer incorrectly and your student catches you, he/she gets a point. If you answer incorrectly and he/she doesn’t catch you, you get a point. The first person to get five points is the winner.

## Let's Connect!

**Materials:** Let's Connect Packet for Combinations to 10 (*enclosed in Student Progress Folder*) / Word Problem Guide Card (*pink card on cart*) / Paper and pencil

**Purpose:** Student practices standards-aligned content to continue reinforcing and developing skills and concepts.

- 1) Together with student, complete half of a page (two squares) in the **Let's Connect** Combinations to 10 packet.
- 2) For any word problems, use the pink Word Problem Card (*found on the cart*) as a guide for how to talk about and work through the problems in a meaningful way.
- 3) Refer to the blue **Let's Connect** Combinations to 10 **Answer Key** (*found on the cart*) to check student work and answers.

***Please see your Program Coordinator! He/she will do a "brain check" to determine if your student is ready to go back to Lesson 1 with the next Focus Number, or to review all numbers.***



HEART

# COMBINATIONS TO 10 LESSON 7 "COMBINATION DOMINATION"

This lesson is for students who are finishing Focus Number 10.

## GOALS

Student reviews combinations for all Focus Numbers.

## ACTIVITIES

*The time required to complete each activity will vary from student to student. Allow student to move at his/her own pace. If more time is needed, lessons can be carried over to the next tutoring session.*

### **Dot Arrangement Review Flash Cards – All Focus Numbers**

### **Dice Race!**

### **Park Place**

### **Elimination**

***After this lesson, check with your Program Coordinator to see if your student is ready to move to the next Concept Notebook.***

## MATERIALS ENCLOSED

None

## MATERIALS TO GET

Connecting Cubes (2 bags,  
different colors)

2 Number Lines (1-10)

2 Yellow Dot Cubes (1-6)

2 Yellow Number Cubes (1-6)

Dot Arrangement Review Flash  
Cards

Paper and pencil

## WRAP-UP

- Compliment student for hard work and provide stickers as a reward.
- Discuss with student the lesson goals that were practiced today.
- Ask student two of the following questions on the way back to class:
  - What was hard about today?
  - What did you feel confident about?
  - Where did you see improvement?
  - What do you still need to practice?
  - How do you feel about your effort today?
- Encourage student to practice "tricky" combinations at home.
- Record brief notes on progress log.

## Dot Arrangement Review Flash Cards – All Focus Numbers

**Materials:** Dot Arrangement Review Flash Cards

**Purpose:** Student practices recognizing groups within numbers for a variety of Focus Numbers.

**“Congratulations on learning all combinations for numbers to 10! It is time for ‘Combination Domination’. We will play the next three games to review combinations for all Focus Numbers.”**

Together with student, flip through the Dot Arrangement Cards one by one. Ask student to identify the total shown on the cards as quickly as possible without counting by ones or twos. After student identifies the total, ask him/her to point out the groups he/she sees within the number.

To prompt student to use and combine recognizable groups, ask,

**“What groups do you see?”**

**“How many is that altogether?”**

Or, if student begins by telling the total, ask,

**“How did you see that?”**

Example for 9 Card:

The student might see groups of 4 and 5 and say, “ $4 + 5 = 9$ .” Another student might see groups of 4, 3, and 2 and say “ $4 + 3 + 2 = 9$ .”

If student counts by ones or twos, ask him/her **“Is there another way you can see that?”**

Encourage student to identify larger groups emphasizing the combinations for his/her Focus Number. Counting by twos is still considered “counting” and is not the same skill as recognizing groups and adding them together.

### **Optional – Timed Game**

For students who enjoy a race, time student to see how many cards he/she can identify, using known combinations, in 3 minutes. Write down the number of cards, then play again to see if he/she can beat the number.



## Dice Race!

**Materials:** Connecting Cubes (2 bags, different colors) / 2 Yellow Dot Cubes (1-6) / 2 Yellow Number Cubes (1-6)

**Purpose:** Student reviews combinations up to 10.

### Part I: Dot Cubes

Using Connecting Cubes of one color as “points”, award a cube to the winner.

Ask student to roll 2 Yellow Dot Cubes and to tell the sum as quickly as he/she can.

If student tells the sum within 3 seconds, *without counting by ones*, student gets a point. If student has not announced the sum within tutor’s count of three, tutor tells the sum and gets the point.

Continue until 20 Connecting Cubes of one color are awarded as points.

Keep student’s cubes in a pile off to one side.

### Part II: Number Cubes

Use 2 Yellow Number Cubes and the second color of Connecting Cubes as points and repeat activity.

When 20 Connecting Cubes of the second color have been awarded as points, note whether student is better at recognizing dots or numerals by comparing the student’s two piles of cubes.

Provide more practice with either dots or numerals, depending on what student needs.

It’s important to practice with both numerals and dots to ensure student is recognizing groups of dots (rather than counting) and is associating numerals with quantities (rather than memorizing equations).

## Park Place

**Materials:** Paper and pencil

**Purpose:** Student practices finding recognizable groups and combining them.

Tell student,

**“Today we are going to look at a picture of a park and answer questions about the total number of items. You are going to practice finding recognizable groups of objects and combining them to find the total, rather than counting by ones.”**

Ask the student the following questions about the picture below. Ensure student is telling you the groups and/or equation he/she sees rather than counting by ones.

- How many clouds do you see?
- How many swings do you see?
- How many balls do you see?
- How many balloons do you see?
- How many flowers do you see?

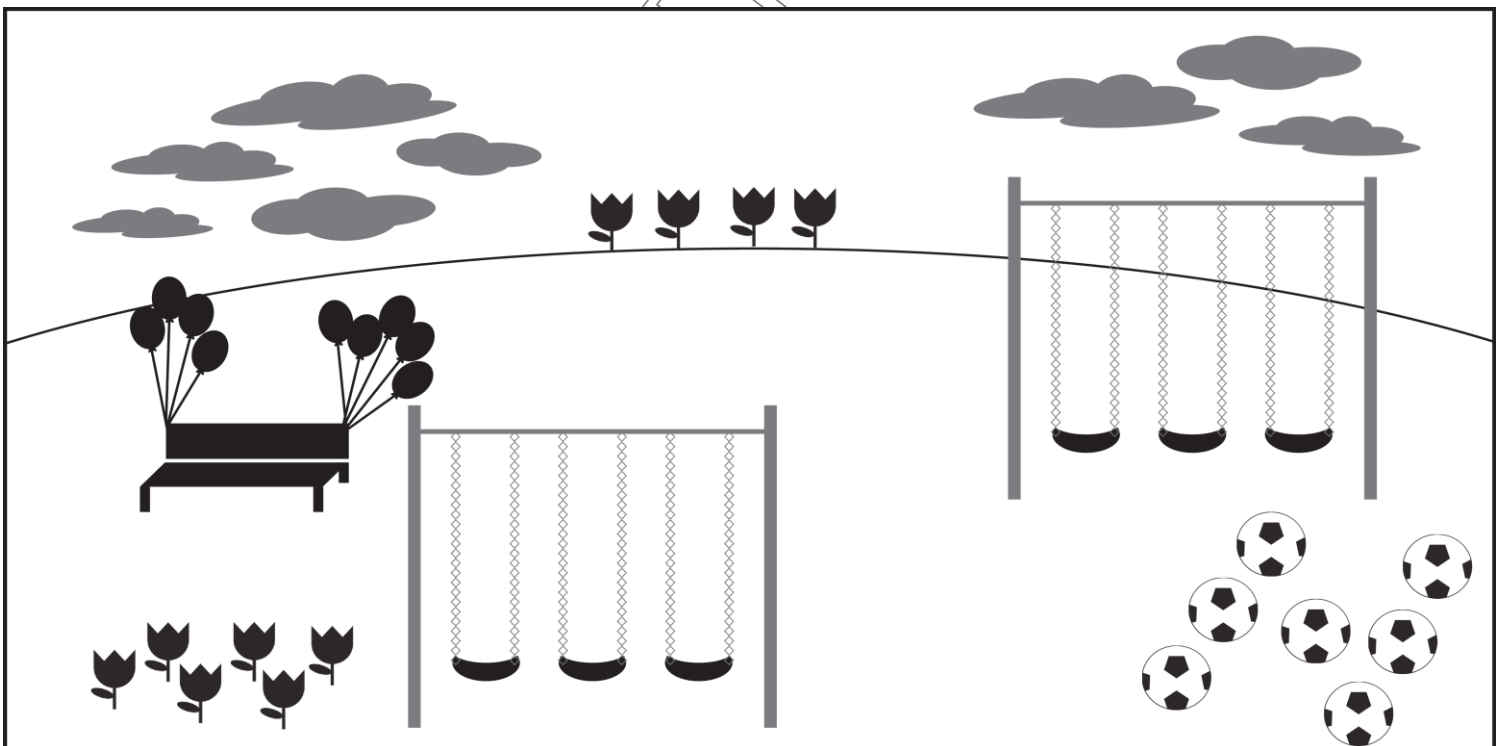

## Elimination

**Materials:** 2 Yellow Number Cubes (1-6) / Connecting Cubes (2 bags, different colors) / 2 Number Lines (1-10)

**Purpose:** Student reviews combinations up to 10.

**NOTE:** Players should use knowledge of combinations *WITHOUT COUNTING BY ONES!*

Each player chooses their color of Connecting Cubes and places the Number Line in front of them.

First player's turn:

- First player rolls two Number Cubes and determines the sum. He/she then places Connecting Cubes on his/her board to cover EITHER the sum OR any combination that adds up to the sum.

*For example, if a player rolls 4 and 5, he/she can cross off one of the following:*

9  
8 and 1  
7 and 2  
6 and 3  
5 and 4

- First player continues to roll and cover numbers until he/she is stuck, meaning all possible combinations for the numbers rolled have already been crossed out, and he/she is not able to do anything on the board.
- When the first player becomes stuck, he/she calculates his/her final score by adding all number that are not yet crossed out.

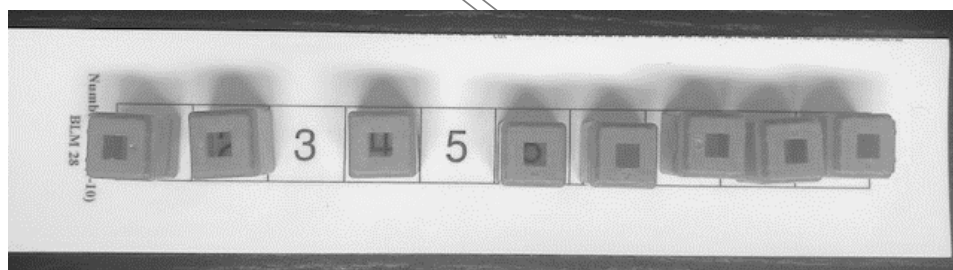

Example final score board where final score is 8.

Second player repeats what first player has done.

Whoever has the lowest score wins!

Play game multiple times.



HEART  
MATH TUTORING

Lessons and Activities for

# Strategies to 20

*Volunteer Check-Out Materials*

The materials in this notebook are to be used only in conjunction with Heart Math Tutoring. Please contact the administrator of this program before reproducing any materials found in this notebook.

# STRATEGIES TO 20

## Concept Overview

### CONCEPT GOALS

*Student will be able to:*

1. Recognize groups of 10 as units that can be added.
2. Add and subtract groups of 10 to numbers without counting.
3. Add and subtract numbers up to 20 using known combinations and the underlying structure of tens and ones. Explain.
4. Solve word problems for numbers up to 20.

### END OF PROGRAM ASSESSMENT

*Knowing how students will be assessed can help guide instruction.*

**Example 1: Ten Frames for Addition** – Assessor will show two ten frames with numbers that can be added to equal a number between 11 and 20 and ask student, “How many would this be altogether? How do you know?” Student’s explanation should demonstrate ability to use known combinations and reorganize parts into a ten and leftovers.

**Example 2: Ten Frames for Subtraction** – Assessor will show a number between 10 and 20 on ten frames and ask “How many would be left if I take ‘x’ away? How do you know?” Student’s explanation should demonstrate knowledge of combinations that relate to the underlying structure of tens and ones.

**Example 3: Mental Addition and Subtraction** – Assessor will give student an addition or subtraction problem verbally (without ten frames). Student must explain his/her method of solving as described above.

### KEY POINTS

*The information below may assist you in helping your student.*

- Our number system is based on tens. Ten Frames are used in this unit to help students use 10 as a reference point when adding and subtracting. These skills are important for working in the “teens” (numbers between 11 and 20) and for future work with much higher numbers.
- Tutors should focus on helping student use his/her knowledge of parts of numbers (combinations) to work efficiently in the base ten system.
- The questions being asked in this Notebook are “How many do you need to make a ten?” and “How many do you have left over?”

### GOALS

*Student will be able to:*

1. Recognize groups of 10 as units that can be added.
2. Add and subtract groups of 10 to numbers without counting.
3. Solve word problems for numbers up to 20.

### ACTIVITIES

*The time required to complete each activity will vary from student to student. Allow student to move at his/her own pace. If more time is needed, lessons can be carried over to the next tutoring session.*

**Doubles Plus One/Minus One for Sums Greater than Ten**

**Making Tens**

**Adding Tens with Ten Frame Cards**

**Let's Connect**

### MATERIALS ENCLOSED

Ten Frame Cards

### MATERIALS TO GET

Connecting Cubes (3 bags of one color, 1 bag of a different color)

3 Red bowls

Paper and pencil

Let's Connect Packet for  
Strategies to 20

### WRAP-UP

- Compliment student for hard work and provide stickers as a reward.
- Discuss with student the lesson goals that were practiced today.
- Ask student two of the following questions on the way back to class:
  - What was hard about today?
  - What did you feel confident about?
  - Where did you see improvement?
  - What do you still need to practice?
  - How do you feel about your effort today?
- Record brief notes on progress log.

## Doubles Plus One/Minus One for Sums Greater than Ten

**Materials:** Connecting Cubes (2 bags, different colors) / Paper and pencil

**Purpose:** Student practices using the strategy of adding one or subtracting one from known doubles greater than ten.

Tell student,

**“We are starting a new concept notebook that focuses on adding and subtracting numbers up to 20. You will use combinations you already know to figure out sums of larger numbers.**

**What are some doubles combinations you already know with sums greater than 10?”**

If student doesn't understand, provide examples such as  $6 + 6 = 12$ , and  $8 + 8 = 16$ .

Write down the equation for each doubles combination student names.

### Doubles Plus One

Ask student,

**“Since you know that  $6 + 6$  equals 12, do you know what  $6 + 7$  equals?”**

If student doesn't immediately know the answer, ask him/her to use two colors of cubes to create a train that matches this combination as shown below.



Then ask student to add one cube of matching color to one end of the train to show/figure out the answer to the new combination.



Ask student to write the doubles equation ( $6 + 6 = 12$ ) and the new equation ( $6 + 7 = 13$ ).

Ask student to describe what he/she notices about the two equations. *When one of the numbers added increases by one, the sum increases by one.*

## Doubles Minus One

Ask student,

**“Since you know that  $6 + 6 = 12$ , do you know what  $6 + 5$  equals?”**

If student doesn't immediately know the answer, ask him/her to figure it out making the  $6 + 6$  train as he/she did before and taking one cube off the end.



Ask student to write the two equations and discuss how they are related. *When one of the numbers added decreases by 1, the sum also decreases by one.*

Ask student to write the “Doubles Plus One” and “Doubles Minus One” equations for each of the doubles he/she knows. Student can use cube trains to show the equations if needed.



## Making Tens

**Materials:** Connecting Cubes (3 bags of the same color) / 3 Red bowls

**Purpose:** Student becomes comfortable seeing tens as units and relating that to the total.

Fill two bowls with Connecting Cubes and ask student to guess/estimate how many there are all together.

**“How many cubes do you think are in the bowls?”**

After student says a number, ask,

**“If you think there are ‘x’ in all, how many groups of ten do you think there are?”**

Ask student to determine the total number of cubes by putting them into groups of ten, counting the groups of ten and adding the leftovers.

**NOTE:** Some students will count by tens (10, 20, 30) and then add the leftovers. Others will count the tens as units (“three tens is 30”) and add the leftovers. Both ways are acceptable for this activity, but students should eventually be able to recognize tens as units and know immediately that three groups of 10 make 30.

Repeat, asking student to fill three bowls with cubes.

This time, both tutor and student should make estimates.

Based on student’s estimate, ask him/her to tell how many groups of tens there should be. Then ask him her to find the total as described above.

Repeat the activity several times for different quantities.

## Adding Tens with Ten Frame Cards

**Materials:** Ten Frame Cards / Paper and pencil

**Purpose:** Student becomes comfortable adding and subtracting multiples of ten.

Tell student,

**“We are going to practice knowing how many dots are on a Ten Frame and being able to add one or more completed tens to that number.”**

### **PART I: Looking at Partially Filled Ten Frames**

Show student the Ten Frame Cards in random order and ask him/her to say quickly how many dots are on each card.

If student is slow to recognize any of the numbers, look at the cards together and ask student to notice how the dots relate to 5 and to 10 as shown below.

Example for 9:

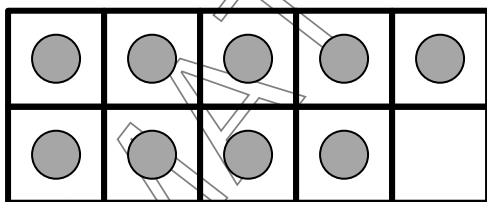

Ask student,

**“What’s an easy way to see that there are 9 dots here?”**

Help student see the groups of 5 and 4 and to see that one dot is missing from 10.

### **PART II: Adding One Ten to Partially Filled Ten Frames**

Place a Ten Frame Card with between 1 and 9 dots on the table and ask student to tell the number it represents.

Place a filled Ten Frame Card beside the first card and ask student,

**“How many dots are on both cards together?”**

Example for 7 and 10:

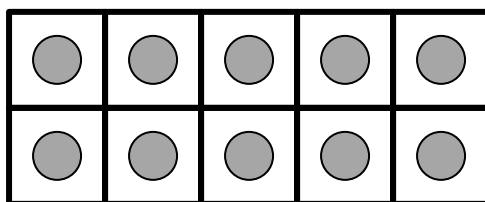
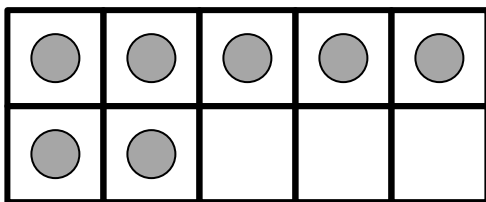

Let student figure out the total in whatever way he/she chooses.

Repeat with a variety of numbers. Ask student to write the addition equation on paper to help him/her recognize the structure of tens and ones.

Write on paper a mixture of problems as shown below and ask student to tell the answers. Allow him/her to use Ten Frames if needed.

$4 + 10$

$16 - 10$

$5 + 10$

$19 - 10$

$8 + 10$

$11 - 10$

$2 + 10$

$17 - 10$

### **PART III: Adding More Than One Ten to a Partially Filled Ten Frame**

Repeat PART II, adding two or more tens to the original number. (e.g.,  $4 + 20$ ,  $9 + 30$ )

### **PART IV: Story Problems**

Make up story problems that involve adding one or more tens to a given number and subtracting 10 from a given number. Ask student to write the number problem on paper and to tell the answer. Allow him/her to use Ten Frames if needed.

Ask student to make up his/her own problems and to tell the answers.

## Let's Connect!

**Materials:** Let's Connect Packet for Strategies to 20 (*enclosed in Student Progress Folder*) / Word Problem Guide Card (*pink card on cart*) / Paper and pencil

**Purpose:** Student practices standards-aligned content to continue reinforcing and developing skills and concepts.

- 1) Together with student, complete one page (four squares) in the **Let's Connect** Strategies to 20 packet.
- 2) For any word problems, use the pink Word Problem Card (*found on the cart*) as a guide for how to talk about and work through the problems in a meaningful way.
- 3) Refer to the purple **Let's Connect** Strategies to 20 **Answer Key** (*found on the cart*) to check student work and answers.

### GOALS

*Student will be able to:*

1. Add and subtract numbers up to 20 using known combinations and the underlying structure of tens and ones. Explain.
2. Solve word problems for numbers up to 20.

### ACTIVITIES

*The time required to complete each activity will vary from student to student. Allow student to move at his/her own pace. If more time is needed, lessons can be carried over to the next tutoring session.*

#### **Rearranging into Tens and Leftovers**

#### **Ten Frame Addition (9+ and 8+)**

#### **Let's Connect**

#### **Combos to 10 Review Games**

### MATERIALS ENCLOSED

2 Blank Ten Frames

Ten Frame Cards

### MATERIALS TO GET

Connecting Cubes (2 bags, different colors)

1 Red Number Cube (4-9)

2 Yellow Number Cubes (1-6)

Paper and pencil

### IN PROGRESS FOLDER

Let's Connect Packet for  
Strategies to 20

### WRAP-UP

- Compliment student for hard work and provide stickers as a reward.
- Discuss with student the lesson goals that were practiced today.
- Ask student two of the following questions on the way back to class:
  - What was hard about today?
  - What did you feel confident about?
  - Where did you see improvement?
  - What do you still need to practice?
  - How do you feel about your effort today?
- Record brief notes on progress log.

## Rearranging into Ten and Leftovers

**Materials:** Connecting Cubes (2 bags, different colors) / 2 Blank Ten Frames

**Purpose:** Student practices adding two numbers whose sum is greater than 10 by rearranging cubes to make a ten with leftovers.

Tell student,

**“Our number system is organized into tens. You have seen how easy it is to add a ten to any number. You also know how to break numbers into two parts (combinations). We are going to practice using combinations to rearrange numbers into tens and leftovers.”**

Choose two numbers that add up to a number between 11 and 20. Ask student to put cubes representing the two numbers on the Blank Ten Frames as shown below. (Use two different colors for the two numbers.)

Example for 8 red and 5 yellow cubes:

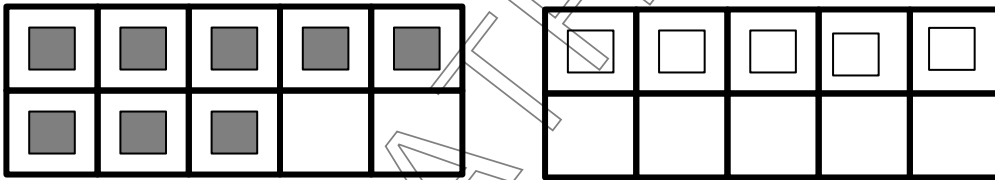

Ask student,

**“How can you rearrange these cubes so it is easy for you to quickly see how many you have in all?”**

Allow student to brainstorm about ways to make it easier. After exploring whatever options student recommends, encourage student to move the yellow cubes to complete the Ten Frame with the red cubes as shown below:

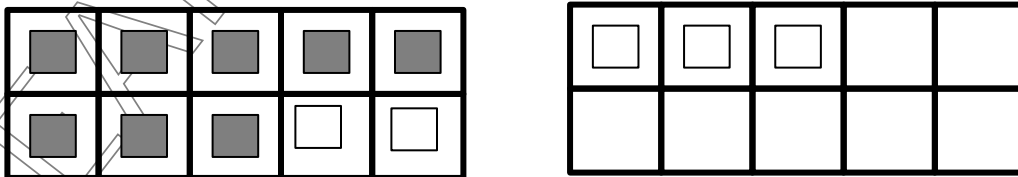

Ask student:

**"Now that you've rearranged the cubes, can you tell me easily how many you have altogether?"**

**"How many cubes are in the filled frame? How many are leftover? How many do we have altogether?"**

Repeat activity several times, rearranging cubes into one ten and leftovers. Ask student, "*How many leftovers?*" and "*How many altogether?*" after the cubes are rearranged.

HEART MATH TUTORING

## Ten Frame Addition (9+ and 8+)

**Materials:** Connecting Cubes (1 bag) / 1 Red Number Cube (4-9) / Ten Frame Cards

**Purpose:** Student explores completing a ten and determining leftovers when adding above 10.

### PART I: Adding Any Number to 9

Tell student,

**“We are going to practice adding any number to 9.”**

Place a Ten Frame Card filled with 9 dots on the table.

Put a pile of 4 cubes beside the card and say,

**“We have 9 on the Ten Frame. I want to add 4 cubes to this 9. (So,  $9 + 4$ .)”**

**“How many will I have altogether?”**

Allow student to answer in whatever way they choose.

Model how to use knowledge of tens to find the total without having to count by ones saying,

**“How many cubes would I need to complete this frame of 10?”** *Student should answer 1. Tutor should put one cube on the empty square as shown below.*

**“When you take 1 cube from the 4 cubes we started with, how many cubes would be leftover?”** *Student should say 3.*

**“How many cubes would we have altogether?”** *Student should see that there are  $10 + 3$  or  $13$ .*

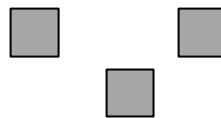
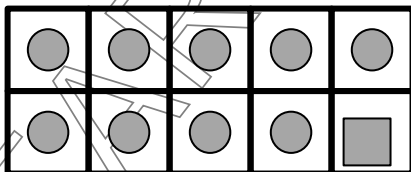

Tell student,

**“Now I want you to try a few more. You can roll the Number Cube to determine what number to add to 9.”**



Ask student to roll the Number Cube several times and add a variety of numbers to 9.

For the first few rolls, allow student to work with the cubes to complete the 10 and to see the leftovers.

For the next few rolls, encourage student to use their knowledge of combinations to predict what the leftovers will be.

**NOTE:** After student rolls the Number Cube, tutor can hide the group of cubes under their hand and make the student request the number of cubes needed to complete the ten. Student must then use their knowledge of combinations to determine the "leftovers".

**PART II: Adding Any Number to 8**

Repeat PART I using the 8 dot Ten Frame Card instead of the 9.

**PART III: Using Fact Families to Add**

Tell student,

**"It's important that you are always using your knowledge of combinations to add, rather than counting by ones. One way to help us with this is to use the visual of fact families to see what combination will allow us to make a new ten. "**

Have your student determine the missing pieces in each fact family that will allow them to make a new ten. Then complete the problem by adding the ten plus leftovers to find the total. (As you work through the problems, help students make the connection to what they just did with the Ten Frame cards in Part I & II. It's now just represented with fact family boxes.)

Examples:

① "Let's think about how we can take our starting number (8) and make a friendly 10. What number do we need to add to 8 to make it a 10?"

② Ensure student understands to break the number being added (6) into a combination where one piece of the combo will help them make the starting number (8) into a 10.

③ "Now we can think about the addition problem as adding the ten + leftovers to find the total!"

Part Makes 9 into a 10

Part leftovers

**\*\*Note:** To determine the parts, students shouldn't be counting since they have mastered Combinations to 10- you may need to briefly review relevant combinations (in this case, combos to make 6 and combos to make 10).

Whole

Part Part

Whole

Part Part

Whole

Part Part

## Let's Connect!

**Materials:** Let's Connect Packet for Strategies to 20 (*enclosed in Student Progress Folder*) / Word Problem Guide Card (*pink card on cart*) / Paper and pencil

**Purpose:** Student practices standards-aligned content to continue reinforcing and developing skills and concepts.

- 1) Together with student, complete one page (four squares) in the **Let's Connect** Strategies to 20 packet.
- 2) For any word problems, use the pink Word Problem Card (*found on the cart*) as a guide for how to talk about and work through the problems in a meaningful way.
- 3) Refer to the purple **Let's Connect** Strategies to 20 **Answer Key** (*found on the cart*) to check student work and answers.

## Combos to 10 Review Games

**Materials:** Connecting Cubes (1 bag) / 2 Yellow Number Cubes (1-6) / Paper and pencil

**Purpose:** Student reviews combinations for a variety of Focus Numbers up to 10.

### **Mandatory Review Game: Elimination**

**NOTE:** *Players should use knowledge of combinations WITHOUT COUNTING BY ONES!*

Each player makes a game board by writing the numbers 1 through 10 horizontally on a sheet of paper.

First player's turn:

- First player rolls two Number Cubes and determines the sum. He/she then crosses out on his/her board EITHER the sum OR any combination that adds up to the sum.

*For example, if a player rolls 4 and 5, he/she can cross off one of the following:*

9  
8 and 1  
7 and 2  
6 and 3  
5 and 4

- First player continues to roll and cross out numbers until he/she is stuck, meaning all possible combinations for the numbers rolled have already been crossed out, and he/she is not able to do anything on the board.
- When the first player becomes stuck, he/she calculates his/her final score by adding all number that are not yet crossed out.

Second player repeats what first player has done. Whoever has the lowest score wins!

Play game multiple times.

### **Additional Optional Game (as needed): Hiding Game**

**NOTE:** *The Hiding Game involves naming the missing part (subtraction) which is much more difficult for students than adding. The goal is for students to quickly "know" or be able to quickly reason to the answers.*

Ask student to count out the number of cubes for the Focus Number.

◇ Hide all of the cubes under your hand.

Pull out 2 cubes and leave them showing on the table.

Ask student,

**“How many are still hidden?”**

Repeat by showing different quantities of cubes until every possible combination has been tested.

Tips for helping students:

- If the quantity shown is large, it may be easier to think about the problem as addition. (If  $8 - 6$  is difficult, suggest thinking about  $6 + \underline{\quad} = 8$ )
- If the quantity shown is close to a double, it may be easier to think of the double and make an adjustment to find the answer. ( $8 - 4 = 4$ , so  $8 - 3$  must be 5)

HEART MATH TUTOR

### GOALS

*Student will be able to:*

1. Add and subtract numbers up to 20 using known combinations and the underlying structure of tens and ones. Explain.
2. Solve word problems for numbers up to 20.

### ACTIVITIES

*The time required to complete each activity will vary from student to student. Allow student to move at his/her own pace. If more time is needed, lessons can be carried over to the next tutoring session.*

#### **Visualizing Addition with Ten Frames**

#### **Ten Frame Card Game – Addition**

#### **Let's Connect**

#### **Combos to 10 Review Games**

### MATERIALS ENCLOSED

Ten Frame Cards

### MATERIALS TO GET

Connecting Cubes (2 bags, different colors)

Deck of Cards

2 Yellow Number Cubes (1-6)

2 Yellow Dot Cubes (1-6)

Domino Cards

Paper and pencil

### IN PROGRESS FOLDER

Let's Connect Packet for Strategies to 20

### WRAP-UP

- Compliment student for hard work and provide stickers as a reward.
- Discuss with student the lesson goals that were practiced today.
- Ask student two of the following questions on the way back to class:
  - What was hard about today?
  - What did you feel confident about?
  - Where did you see improvement?
  - What do you still need to practice?
  - How do you feel about your effort today?
- Record brief notes on progress log.

## Visualizing Addition with Ten Frames

**Materials:** Ten Frame Cards

**Purpose:** Student visualizes number in relation to ten to add a variety of numbers.

Tell Student,

**“We are going to continue to use our knowledge of combinations and tens to add up to make larger numbers.”**

**NOTE:** If student is unable to understand the process visually, continue to work with cubes.

### **PART I: Visualizing 9+**

Present the 9 dot Ten Frame Card and another partially filled card. Ask student how he/she could use ten and knowledge of combinations to help determine the total.

Example for  $9 + 6$ :

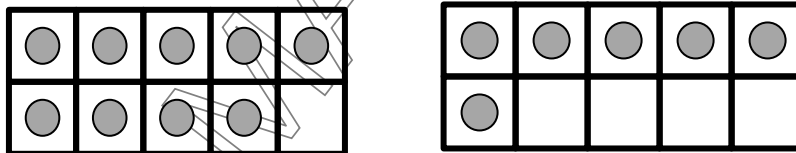

If help is needed, use loose cubes to present the second number. Allow student to complete the ten and find the leftovers with cubes.

To prompt student thinking, ask:

**“How many would you need to make 10?”** Answer: 1.

**“How many “left overs” would you have?”** Answer: 5 (I broke the 6 into 1 and 5).

**“If you have one complete 10 and 5 left over, what is the total?”** Answer:  $10 + 5 = 15$ .

**NOTE:** Encourage student to think about combinations rather than counting to determine the leftovers. One way to do so in the example above is to ask, **"What combination of 6 would you use to break it apart?"**

Repeat for 9 plus other numbers.

### **PART II: Visualizing 8+**

Present the 8 dot Ten Frame Card and another partially filled card. Ask student how he/she could use ten and knowledge of combinations to help determine the total.

Example for 8 + 6:

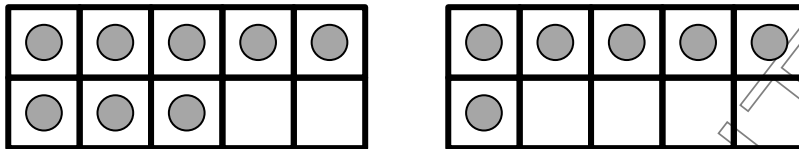

If help is needed, use loose cubes to present the second number. Allow student to complete the ten and find the leftovers with cubes.

To prompt student thinking, ask:

**"How many would you need to make 10?"** Answer: 2.

**"How many "left overs" would you have?"** Answer: 4 (I broke the 6 into 2 and 4).

**"If you have one complete 10 and 4 left over, what is the total?"** Answer:  $10 + 4 = 14$ .

Repeat for 8 plus other numbers.

**NOTE:** Encourage student to think about combinations rather than counting to determine the leftovers. One way to do so in the example above is to ask, **"What combination of 6 would you use to break it apart?"**

### **PART III: Visualizing 7+ and 6+**

Continue the activity using 7 and 6 as the starting Ten Frame numbers.

### **PART IV: Visualizing Any Number**

Continue the activity but mix up the starting Ten Frame numbers.

## Ten Frame Card Game – Addition

**Materials:** Deck of Cards / Ten Frame Cards

**Purpose:** Student practices adding a variety of numbers using relationships to ten.

### Part I: Addition with Ten Frame Cards

Remove Jack, Queen and King from card deck and set deck on table.

Ask student to pick a starting number for the game (6, 7, 8, or 9) and put the Ten Frame Card for that number on the table.

Ask student to turn over the top card in the deck and to add the number to the Ten Frame Card. He/she should be able to rearrange the numbers to complete a full ten and have some left over. Ask student to explain his/her answer in three parts:

I need \_\_\_\_\_ to make a ten.  
I would have \_\_\_\_\_ left over.  
The total is \_\_\_\_\_.

If student answers correctly, he/she keeps the card. If not, tutor gets the card.

**NOTE:** Encourage student to rely on his/her knowledge of combinations rather than counting to determine the leftovers. One way to do so is to ask, "**What combination will you use to break apart the card?**"

### Part II: Addition without Ten Frame Cards

Play the game again, but take away the Ten Frame Card and use a playing card to show the starting number (6, 7, 8, or 9). This will challenge student to think about what is needed to complete the ten without using the Ten Frame as a visual.



## Let's Connect!

**Materials:** Let's Connect Packet for Strategies to 20 (*enclosed in Student Progress Folder*) / Word Problem Guide Card (*pink card on cart*) / Paper and pencil

**Purpose:** Student practices standards-aligned content to continue reinforcing and developing skills and concepts.

- 1) Together with student, complete one page (four squares) in the **Let's Connect** Strategies to 20 packet.
- 2) For any word problems, use the pink Word Problem Card (*found on the cart*) as a guide for how to talk about and work through the problems in a meaningful way.
- 3) Refer to the purple **Let's Connect** Strategies to 20 **Answer Key** (*found on the cart*) to check student work and answers.

## Combos to 10 Review Games

**Materials:** Connecting Cubes (2 bags, different colors) / Domino Cards / 2 Yellow Dot Cubes (1-6) / 2 Yellow Number Cubes (1-6)

**Purpose:** Student reviews combinations for a variety of Focus Numbers up to 10.

### **Mandatory Review Game: Domino War**

Split the cards evenly between the two players.

First, tutor and student each turn over a card and say the sum that is showing on their card. Ensure students are not counting dots by ones or twos. Encourage students to use known combinations to determine the sum on each card.

Then, student tries to say the difference between the two cards while tutor counts slowly to 3.

If student says the answer before tutor gets to 3, he/she keeps both cards. If not, tutor keeps the cards.

Play continues until all of the cards are turned over. The person with the most Domino Cards is the winner.

### **Additional Optional Game (as needed): Dice Race**

#### Part I: Dot Cubes

Using Connecting Cubes of one color as "points", award a cube to the winner.

Ask student to roll 2 Yellow Dot Cubes and to tell the sum as quickly as he/she can.

If student tells the sum within 3 seconds, without counting by ones, student gets a point. If student has not announced the sum within tutor's count of three, tutor tells the sum and gets the point.

Continue until 20 Connecting Cubes of one color are awarded as points.

Keep student's cubes in a pile off to one side.

#### Part II: Number Cubes

Use 2 Yellow Number Cubes and the second color of Connecting Cubes as points and repeat activity.

When 20 Connecting Cubes of the second color have been awarded as points, note whether student is better at recognizing dots or numerals by comparing the student's two piles of cubes.

Provide more practice with either dots or numerals, depending on what student needs.

It's important to practice with both numerals and dots to ensure student is recognizing groups of dots (rather than counting) and is associating numerals with quantities (rather than memorizing equations).

HEART MATH TUTORING

**GOALS**

*Student will be able to:*

1. Add and subtract numbers up to 20 using known combinations and the underlying structure of tens and ones. Explain.
2. Solve word problems for numbers up to 20.

**ACTIVITIES**

*The time required to complete each activity will vary from student to student. Allow student to move at his/her own pace. If more time is needed, lessons can be carried over to the next tutoring session.*

**Subtracting 9 and 8 with Ten Frames****Roll and Subtract with Ten Frames****Ten Frame Card Game – Subtraction****Let's Connect****Combos to 10 Review Games****MATERIALS ENCLOSED**

Ten Frame Cards

**MATERIALS TO GET**

1 Red Number Cube (4–9)

Deck of Cards

Dot Arrangement Cards (All colors)

Paper and pencil

**IN PROGRESS FOLDER**Let's Connect Packet for  
Strategies to 20**WRAP-UP**

- Compliment student for hard work and provide stickers as a reward.
- Discuss with student the lesson goals that were practiced today.
- Ask student two of the following questions on the way back to class:
  - What was hard about today?
  - What did you feel confident about?
  - Where did you see improvement?
  - What do you still need to practice?
  - How do you feel about your effort today?
- Record brief notes on progress log.

## Subtracting 9 and 8 with Ten Frames

**Materials:** Ten Frame Cards

**Purpose:** Student practices using knowledge of parts of numbers (*combinations*) to subtract from numbers between 11 and 20.

Tell student,

**“We know that thinking of numbers as tens and some leftover ones helped us add numbers with sums greater than 10. Now we are going to think about tens and leftover ones when we subtract.”**

### PART I: Subtracting 9 Using Ten Frames

Present two Ten Frames Cards (one filled and one partially filled) and ask student to subtract 9, as shown in the example below.

Example for  $16 - 9$ :

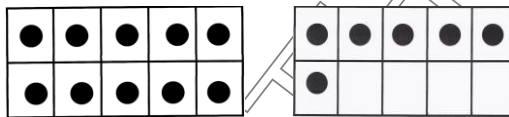

Ask student,

**“If we subtract 9 from this number, how many would be left?”**

If student counts by ones to take away 9, let student know that his/her answer is correct, but encourage him/her to use knowledge of parts of numbers (*combinations*) and tens and ones to subtract more quickly and consistently. Say,

**“Can you do this without counting by 1s? For example, can you take away 9 in parts, using the Ten Frame to help you?”**

If help is needed, model the following as two ways to subtract using knowledge of combinations:

**“If you take the card showing 6 away first, how many would you still need to take from the ten?”**

*Answer: 3, because 9 take away 6 leaves 3.*

**“After you take away 3 how many would be left?”** *Answer: 7.*

**NOTE:** Student may need to use fingers to cover dots. Encourage him/her to use known combinations rather than counting one by one. One way to do so in the example above is to ask **“What combination of 9 will you use to take the 9 away?”**

Continuing to look at the problem above, tell student,

**"We can also look at this problem in a different way."**

**"If you take 9 away from the completed ten first, how many would be left on that Ten Frame?"** *Answer: 1.*

**"If you have 1 left and 6 left, how many are left in all?"** *Answer: 7.*

Repeat, subtracting 9 from different sets of Ten Frame Cards (one filled and one partially filled).

## **PART II: Subtracting 8 Using Ten Frames**

Present two Ten Frames (one filled and one partially filled) and ask student to subtract 8, as shown in the example below:

Example for  $14 - 8$ :

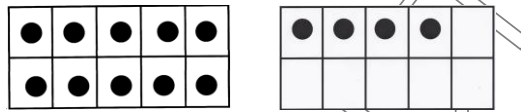

Ask student,

**"If we subtract 8 from this number, how many will be left?"**

If student counts by ones to determine the answer, help him/her use knowledge of combinations and tens and leftovers to subtract.

If help is needed ask,

**"If you take the group of 4 away first, how many will you still need to take from the ten?"**

*Answer: 4, because 8 take away 4 leaves 4.*

**"After you take 4 more away how many would be left on the Ten Frame?"** *Answer: 6.*

**NOTE:** Student may need to use fingers to cover dots. Encourage him/her to use known combinations rather than counting one by one. One way to do so in the example above is to ask, **"What combination of 8 will you use to take 8 away?"**

Continuing to look at the problem above, tell student,

**"We can also look at this problem in a different way."**

**"If you take 8 away from the completed ten first, how many would be left on that Ten Frame?"** *Answer: 2.*

**"If you have 2 left and 4 left, how many are left in all?"** *Answer: 6*

## Roll and Subtract with Ten Frames

**Materials:** 1 Red Number Cube (4-9) / Ten Frame Cards

**Purpose:** Student practices subtracting a variety of numbers that require breaking up a complete ten.

Tell student,

**“We are going to practice subtracting a variety of numbers. Try to use your knowledge of combinations so you won’t need to count. The Ten Frame Cards might help you visualize what you are doing.”**

Place a filled Ten Frame Card face up in front of student and spread Ten Frame Cards for numbers 1 to 5 face down on the table.

Tell student,

**“To determine our starting number, pick one of the cards that are face down and place it face up beside the filled Ten Frame.”**

**Now roll the Number Cube to determine what number we will subtract. Think about how you can use parts of numbers (combinations) to help you.”**

Ask student to subtract the number rolled from the two Ten Frames and to explain his/her method for doing so.

Example for  $12 - 7$ :

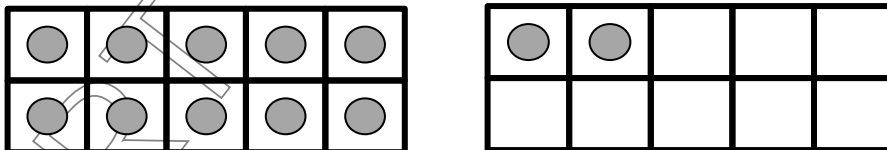

Two possible methods for subtracting:

- Take away the group of two and then take 5 from the 10, leaving 5.
- Take 7 from the completed 10, leaving 3 and 2, for a total of 5.

Example for 15 - 4:

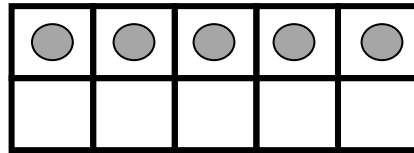
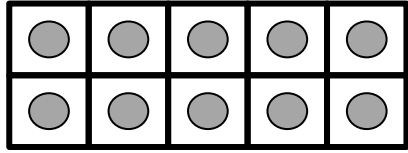

Two possible methods for subtracting:

- Take away a 4 from the 5, leaving 10 and 1 for a total of 11. *(This is the easiest.)*
- Take 4 from the completed 10, leaving 6 and 5 for a total of 11.

After several rolls, ask student to pick a different card to go with the filled Ten Frame.

Repeat until all the cards on the table have been used.

HEART MATH TUTORING



## Ten Frame Card Game – Subtraction

**Materials:** Deck of Cards / Ten Frame Cards

**Purpose:** Student practices subtracting from a variety of numbers between 11 and 20 using relationships to ten.

### **Part I: Subtraction with Ten Frame Cards**

Remove face cards (Jack, Queen and King) from card deck.

Ask student to pick a starting number for the game (between 11 and 20) and to put a filled Ten Frame Card and a partially filled Ten Frame Card on the table to represent that number.

**NOTE:** Ensure that student spends at least half of his/her practice subtracting from numbers between 11 and 15, where he/she will more frequently be required to take away some ones from the completed ten to determine the difference.

Ask student to turn over the top card in the deck and to subtract that number from the Ten Frame. Ask student to explain his/her steps for doing so.

If student answers correctly, he/she keeps the card. If not, tutor gets the card. Whoever has more cards at the end wins.

In the beginning, student may want to cover some of the dots to help him/her see what is left. Allow him/her to do this for a short period of time, then encourage student to rely on knowledge of combinations.

### **Part II: Subtraction without Ten Frame Cards**

Play the game again, but take away the Ten Frame Cards. Choose a starting number between 11 and 20. This will challenge student to think about the combination needed for subtracting without a visual aid.

If student answers correctly, he/she keeps the card. If not, tutor gets the card. Whoever has more cards at the end wins.

If student struggles, alternate between using the Ten Frame Cards as visuals and solving problems without the visuals, and/or use prompts like in the example problem below to support him/her.

Example for 14-8:

**“Describe what ten frame cards would be used to make the 14. Now where do you want to take the 8 from?”**

## Let's Connect!

**Materials:** Let's Connect Packet for Strategies to 20 (*enclosed in Student Progress Folder*) / Word Problem Guide Card (*pink card on cart*) / Paper and pencil

**Purpose:** Student practices standards-aligned content to continue reinforcing and developing skills and concepts.

- 1) Together with student, complete one page (four squares) in the **Let's Connect** Strategies to 20 packet.
- 2) For any word problems, use the pink Word Problem Card (*found on the cart*) as a guide for how to talk about and work through the problems in a meaningful way.
- 3) Refer to the purple **Let's Connect** Strategies to 20 **Answer Key** (*found on the cart*) to check student work and answers.

## Combos to 10 Review Games

**Materials:** Deck of Cards / Dot Arrangement Flash Cards (All colors)

**Purpose:** Student reviews combinations for a variety of Focus Numbers up to 10.

### Mandatory Review Game: War with Playing Cards

Divide cards evenly between players. Each player turns over a card. Student must say the difference between the cards before tutor completes a slow count to three. If student does so, he/she keeps the cards. If not, tutor keeps the cards.

You can either remove the Jack, Queen, and King, or keep them in as an added challenge. Jack = 11, Queen = 12, and King = 13

### Additional Optional Game (as needed): Dot Arrangement Card Flash

Together with student, flip through the Dot Arrangement Cards one by one. Ask student to identify the total shown on the cards as quickly as possible without counting by ones. After student identifies the total, ask him/her to point out the groups he/she sees within the number.

For example, for a card showing 9, the student might say, "4 + 5 = 9" if he/she sees a group of 4 and of 5 on the card. (Other combinations to 9 are acceptable, depending on how the student sees the groups of dots/shapes.)

To prompt student to use and combine recognizable groups, ask,

**"What groups do you see?"**

**"How many is that altogether?"**

Or, if student begins by telling the total, ask,

**"How did you see that?"**

**Note:** *Counting by ones or twos is not satisfactory. Encourage student to identify larger groups, emphasizing the combinations you have practiced in the Combinations to 10 concept level.*

### GOALS

*Student will be able to:*

1. Apply and explain strategies for adding and subtracting numbers up to 20.
  - Using knowledge of combinations, combine two numbers by reorganizing the parts into a ten and ones.
  - Subtract using combinations that relate to the underlying structure of tens and ones.
2. Solve word problems for numbers up to 20.

### ACTIVITIES

*The time required to complete each activity will vary from student to student. Allow student to move at his/her own pace. If more time is needed, lessons can be carried over to the next tutoring session.*

#### **Teen Addition and Subtraction**

#### **Teen Word Problems**

#### **War for Sums Greater than 10**

#### **Let's Connect**

### MATERIALS ENCLOSED

None

### MATERIALS TO GET

Deck of Cards

Paper and pencil

### IN PROGRESS FOLDER

Let's Connect Packet for  
Strategies to 20

### WRAP-UP

- Compliment student for hard work and provide stickers as a reward.
- Discuss with student the lesson goals that were practiced today.
- Ask student two of the following questions on the way back to class:
  - What was hard about today?
  - What did you feel confident about?
  - Where did you see improvement?
  - What do you still need to practice?
  - How do you feel about your effort today?
- Record brief notes on progress log.

## Teen Addition and Subtraction

**Materials:** Paper and pencil

**Purpose:** Student practices using combinations and relationships to ten to solve written problems.

Write the problems below on a piece of paper for student to solve. Encourage student to think about the problem and what he/she knows about the number relationships before beginning to work on it.

After student solves each problem, ask,

**“How did you solve the problem?”**

If needed to encourage more thorough explanations, ask,

(For addition) **“How did you make a ten with leftovers?”**

(For subtraction) **“Describe the ten frame cards you would use. From where did you take the number?”**

Notice how he/she approaches the problems.

- Does he/she revert back to counting?
- Does he/she try to employ a learned procedure that it not needed? (For example, some students have learned the procedure of “borrowing” from the tens place, which is unnecessary for problems with numbers up to 20.)

**NOTE:** If needed, students may alternate between using Ten Frame Cards and solving without visuals. If student struggles with a particular subtraction problem, suggest that he/she experiment with finding the answer by thinking in terms of addition. For example, if the problem is  $12 - 8$ , some students may prefer to think about “8 plus what makes 12”. This is especially true when the number being subtracted is large.

$5 + 8 =$

$6 + 9 =$

$9 + 4 =$

$7 + 6 =$

$12 - 7 =$

$14 - 5 =$

$13 - 9 =$

$11 - 8 =$

Write additional problems on the paper, if more practice is needed.

## Teen Word Problems

**Materials:** Paper and pencil

**Purpose:** Student practices using combinations and relationships to ten to solve word problems.

Ask student to read and solve on blank paper the word problems below. Encourage the use of strategies he/she has learned.

After student solves each problem, ask,

**“How did you solve the problem?”**

If needed to encourage more thorough explanations, ask,

(For addition) **“How did you make a ten with leftovers?”**

(For subtraction) **“Describe the ten frame cards you would use. From where did you take the number?”**

**NOTE:** The word “more” can sometimes mislead students because they see it as a key word for needing to add. While this is sometimes true, they must remember that the question “how many more?” requires comparing to find the difference, which is subtraction.

Sarah invited 7 boys and 9 girls to her party. How many people did she invite in all?

Fourteen ducks were swimming on the pond. Eight flew away. How many ducks were left on the pond?

Jose read 8 pages of history homework before dinner. He read 7 pages after dinner. How many pages did Jose read in all?

John has 5 cousins. Rodney has 12 cousins. How many more cousins does Rodney have than John?

Raquel ran for 6 minutes and took a break. Then she ran for 9 minutes. How many minutes did Raquel run in total?

Jaquez collected 17 video games. Davis collected 8. How many more video games does Jaquez have than Davis?

## War for Sums Greater than 10

**Materials:** Deck of Cards

**Purpose:** Student practices adding numbers with sums of 10 or greater.

Remove cards less than 4 and face cards (Jack, Queen, King) from the deck.

Split the cards evenly between the two players.

Each player turns over two cards, tells the sum of his/her cards, and explains how he/she knows the sum. The player's explanation must refer to some strategy other than counting (by ones). For example, the player could use his/her knowledge of doubles combinations or his/her ability to rearrange a number into tens and leftovers using known combinations to 10.

In taking turns, model for student how to explain his/her thinking, using doubles combinations or knowledge of tens and leftovers.

If student needs help creating an adequate explanation, prompt with the following questions:

- How many are needed to make one of the numbers a ten?
- How many leftovers would there be?
- What is the sum of the numbers?

The player with the higher sum gets to take all 4 cards.

If there is a tie, each player turns over a second pair of cards and the player with the higher sum wins all 8 cards.

When all the cards have been used, the player who has kept the most cards is the winner.

## Let's Connect!

**Materials:** Let's Connect Packet for Strategies to 20 (*enclosed in Student Progress Folder*) / Word Problem Guide Card (*pink card on cart*) / Paper and pencil

**Purpose:** Student practices standards-aligned content to continue reinforcing and developing skills and concepts.

- 1) Together with student, complete one page (four squares) in the **Let's Connect** Strategies to 20 packet.
- 2) For any word problems, use the pink Word Problem Card (*found on the cart*) as a guide for how to talk about and work through the problems in a meaningful way.
- 3) Refer to the purple **Let's Connect** Strategies to 20 **Answer Key** (*found on the cart*) to check student work and answers.



### GOALS

*Student will be able to:*

1. Apply and explain strategies for adding and subtracting numbers up to 20.
  - Using knowledge of combinations, combine two numbers by reorganizing the parts into a ten and ones.
  - Subtract using combinations that relate to the underlying structure of tens and ones.
2. Solve word problems for numbers up to 20.

### ACTIVITIES

*The time required to complete each activity will vary from student to student. Allow student to move at his/her own pace. If more time is needed, lessons can be carried over to the next tutoring session.*

#### **War for Subtraction in the Teens**

#### **Near 10**

#### **Let's Connect**

### MATERIALS ENCLOSED

Ten Frame Cards (optional)

### MATERIALS TO GET

Deck of Cards

Paper and pencil

### IN PROGRESS FOLDER

Let's Connect Packet for  
Strategies to 20

### WRAP-UP

- Compliment student for hard work and provide stickers as a reward.
- Discuss with student the lesson goals that were practiced today.
- Ask student two of the following questions on the way back to class:
  - What was hard about today?
  - What did you feel confident about?
  - Where did you see improvement?
  - What do you still need to practice?
  - How do you feel about your effort today?
- Record brief notes on progress log.

## War for Subtraction in the Teens

**Materials:** Deck of Cards / Ten Frame Cards (optional)

**Purpose:** Student practices subtracting from a variety of numbers between 11 and 20.

Remove face cards (Jack, Queen, and King) from card deck.

Find two "ten" cards and place one in front of each player.

Divide remaining cards evenly between each player.

Play war as follows:

- Tutor turns over their top card, places it beside their ten and says the total of the two cards.
- Tutor turns over a second card and subtracts it from the total and says the answer. Tutor-please model for student: explain how you knew the answer, and the explanation must refer to a strategy other than counting (by ones).
- Student does the same as tutor.

NOTE: If student needs help creating an adequate explanation, prompt with the following questions:

- Think about Ten Frame cards and imagine them in your head. Describe to me where you took the (number) from.
- Did you take the number you're subtracting from the full ten, or did you break it into parts before you subtracted?
- What did you do with your leftovers to find your answer?

*\*If student still needs additional help visualizing subtraction, use Ten Frame Cards as the two starting cards instead of playing cards.*

- The player with the higher answer takes both second cards, keeping the tens on the table. If there is a tie, repeat the process, and the player with the higher final answer takes the four additional cards, keeping the tens on the table.
- Continue until the cards in the original piles are used up. The player who "wins" the most cards is the winner.

**Extra Challenge:** To introduce Ten Frame thinking for subtracting above 20, use two or more "ten" cards as the starting point for addition.

## Near 10

**Materials:** Deck of Cards / Paper and pencil

**Purpose:** Student practices adding and subtracting numbers between 10 and 20.

### **Part I: Warm Up**

Remove from the deck cards above 10 and below 4. Flip over three cards, face up.

Tell student,

**“We are going to play a game where each of us gets three cards. Whoever can add and subtract them to make a number closest to 10 gets a point.**

**First we will play a practice round, helping each other see the different ways cards can be added and subtracted.”**

Tutor and student each write several possible ways to add and subtract these three numbers. Compare answers. Help student identify ways he/she hasn't tried. Then, discuss which of the answers is closest to ten.

Example for 4, 8, and 9:

- $4 + 8 - 9 = 3$
- $8 + 9 - 4 = 13$  (closest to 10)
- $9 + 4 - 8 = 5$

Example for 5, 7 and 9:

- $7 + 9 - 5 = 11$  (closest to 10)
- $5 + 7 - 9 = 3$

Do this several times with different sets of three cards until student feels comfortable.

### **Part II: Game**

Deal three cards face up to tutor and three more face up to student.

Tutor and student each choose how they would like to add and subtract their cards, with the goal of finding a total as close to 10 as possible, using all three cards.

**NOTE:** Student may write on paper all of the possible ways to add and subtract the numbers, if needed.

Tutor should occasionally help student see different answers which may be closer to 10 if student is not doing so.

The first player to get 5 points is the winner. (Shuffle and reuse cards as needed.)

**Extra Challenge:** Deal out 4 cards to each player. Players must add three cards and subtract one from the total to get as close to 20 as possible.

## Let's Connect!

**Materials:** Let's Connect Packet for Strategies to 20 (*enclosed in Student Progress Folder*) / Word Problem Guide Card (*pink card on cart*) / Paper and pencil

**Purpose:** Student practices standards-aligned content to continue reinforcing and developing skills and concepts.

- 1) Together with student, complete one page (four squares) in the **Let's Connect** Strategies to 20 packet.
- 2) For any word problems, use the pink Word Problem Card (*found on the cart*) as a guide for how to talk about and work through the problems in a meaningful way.
- 3) Refer to the purple **Let's Connect** Strategies to 20 **Answer Key** (*found on the cart*) to check student work and answers.

**GOALS**

*Student will be able to:*

1. Apply and explain strategies for adding and subtracting numbers up to 50.
  - Using knowledge of combinations, combine two numbers by reorganizing the parts into a ten and ones.
  - Subtract using combinations that relate to the underlying structure of tens and ones.

**ACTIVITIES**

*The time required to complete each activity will vary from student to student. Allow student to move at his/her own pace. If more time is needed, lessons can be carried over to the next tutoring session.*

**Ten Frame Connection – Addition and Subtraction**

***After this lesson is completed, check in with the Program Coordinator to determine if your student is ready to move on to the next Concept Notebook.***

**MATERIALS ENCLOSED**

Ten Frame Cards

**MATERIALS TO GET**

Connecting Cubes (2 bags of the same color)

Paper and pencil

**WRAP-UP**

- Compliment student for hard work and provide stickers as a reward.
- Discuss with student the lesson goals that were practiced today.
- Ask student two of the following questions on the way back to class:
  - What was hard about today?
  - What did you feel confident about?
  - Where did you see improvement?
  - What do you still need to practice?
  - How do you feel about your effort today?
- Record brief notes on progress log.

## Ten Frame Connection – Addition and Subtraction

**Materials:** Connecting Cubes (2 bags of the same color) / Ten Frame Cards for Strategies / Paper and pencil

**Purpose:** Student practices solving multi-digit addition and subtraction problems based on knowledge of place value and parts of numbers.

Tell student,

**“Today we are going to practice connecting the work you’ve done so far in this notebook to adding and subtracting larger numbers.”**

### Part I:

Place the Ten Frame Card showing 8 dots in front of the student. Ask him/her,

**“How many dots are on this Ten Frame Card? 8**

**“How many would there be if we added 6 more?”**

Ensure student is simply visualizing the additional 6 cubes rather than physically adding them. Ask student to explain his/her answer in three parts:

I need \_\_\_\_\_ to make a ten.

I would have \_\_\_\_\_ left over.

The total is \_\_\_\_\_.

Next, add two filled Ten Frames above the Ten Frame Card showing 8 dots. (See diagram to the right.)

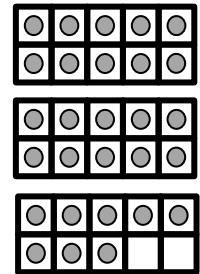

Ask student,

**“How many dots are on the Ten Frame Cards now?” 28**

**“How many would there be if we added 6 more?”**

Ask student to explain his/her answer in three parts:

I need \_\_\_\_\_ to make a *new* ten.

I would have \_\_\_\_\_ left over.

The total is \_\_\_\_\_.

Complete this process (using the Ten Frame Cards as visuals and having student explain his/her answers in three parts) with the following additional problems:

$$7 + 5 = ?$$



$$9 + 6 = ?$$



$37 + 5 = ?$

$29 + 6 = ?$

### **Part II:**

Build 28 with connecting cubes of one color and place in front of student (see picture to the right).

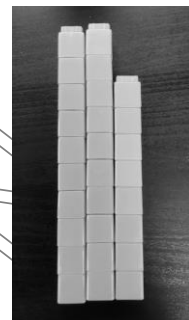

Tell student,

**“Now we are going to solve the same set of problems using connecting cubes rather than Ten Frame Cards.”**

Ask student,

**“How many cubes are on the table?”** 28

**“How many would there be if we added 6 more?”**

If student doesn't use this structure on his/her own, prompt student to explain answer in the following three parts:

I need \_\_\_\_\_ to make a *new* ten.

I would have \_\_\_\_\_ left over.

The total is \_\_\_\_\_.

Complete this process (using the cubes as a visual and having the student explain his/her answers in three parts) with the following additional problems:

$37 + 5 = ?$

$29 + 6 = ?$

### **Part III:**

Tell student,

**“Now we will practice subtraction problems in the same way, starting with Ten Frame Cards.”**

Place two Ten Frame Cards showing 13 dots in front of the student (10 and 3). Ask him/her,

**“How many dots are on this Ten Frame Card?”** 13

**“How many would there be if took away 6?”** *Student's answer should not include counting back or counting by ones.*

If student struggles, ask,

**“Where could you take the 6 from?”**

Next, add two filled Ten Frame Cards above the Ten Frame Card showing 13 dots. (See diagram to the right.)

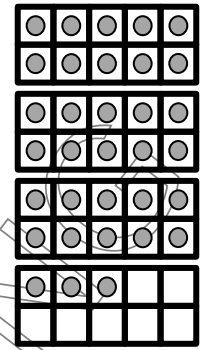

Ask student,

**"How many dots are on the Ten Frame Cards now?"** 33

**"How many would there be if we took away 6?"** *Student's answer should not include counting back or counting by ones.*

Complete this process (using the Ten Frame Cards as visuals and having student explain his/her answers) with the following additional problems:

$14 - 8 = ?$



$24 - 8 = ?$

$12 - 5 = ?$



$32 - 5 = ?$

Build 33 with connecting cubes of one color and place in front of student (see picture to the right).

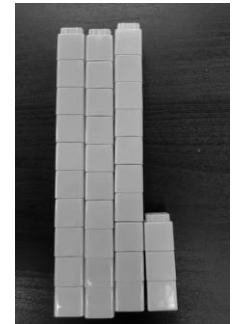

Tell student,

**"Now we are going to solve the same set of problems using connecting cubes rather than Ten Frame Cards."**

Ask student,

**"How many cubes are on the table?"** 33

**"How many would there be if we took away 6?"** *Student's answer should not include counting back or counting by ones.*

Complete this process (using the cubes as a visual and having the student explain his/her answers) with the following additional problems:

$24 - 8 = ?$

$32 - 5 = ?$





Lessons and Activities for

Place Value

&

Multi-Digit Addition and Subtraction

*Volunteer Check-Out Materials*

The materials in this notebook are to be used only in conjunction with Heart Math Tutoring. Please contact the administrator of this program before reproducing any materials found in this notebook.

# PLACE VALUE AND MULTI-DIGIT ADDITION AND SUBTRACTION

## Concept Overview

### CONCEPT GOALS

*Student will be able to:*

1. Make as many hundreds and tens as possible and see the leftovers to determine the total.
2. Mentally add and subtract groups of 10 and 100 fluently.
3. Represent two- and three-digit numbers in different ways by breaking apart and rearranging hundreds, tens, and ones.
4. Solve multi-digit addition and subtraction problems based on knowledge of place value and parts of numbers.
5. Show understanding by explaining solutions verbally or by demonstrating with cubes, a number line, or numeric form.

### END OF PROGRAM ASSESSMENT

*Knowing how students will be assessed can help guide instruction.*

**Example:**

Student will be asked to add and subtract two- and three-digit numbers and to explain using knowledge of place value and parts of numbers. (Pencil and paper will be available as tools.)

### KEY POINTS

*The information below may assist you in helping your student.*

- Our number system is based on forming groups of ten. Once formed, groups of ten ("tens") can be counted as though they were single objects. This is a new concept compared to counting by ones (one-to-one correspondence).
- In this concept notebook, students will be asked to solve two- and three-digit addition and subtraction problems in a variety of ways to strengthen their ability to think flexibly about numbers.
- Some students may already know the standard algorithms that call for "borrowing" and "carrying over", but often they have learned these as *procedures* without truly understanding the number relationships behind the steps involved. Tutors should not refer to "borrowing" and "carrying over" when working in this concept notebook. Instead, tutors should encourage students to make "new tens" and/or "make new hundreds" when adding, and "break up a ten into ones" or "break up a hundred into tens" when subtracting.
- While using standard algorithms is not wrong, relying on rules and procedures can prevent students from thinking logically and efficiently about problems, and when a calculation error occurs, they may be unable to recognize that their answers are unreasonable.
- Some students will move quickly through the lessons. Others may need multiple tutoring sessions on the same lesson.

## GOALS

*Student will be able to:*

1. Make as many tens as possible and see the leftovers to determine the total.
2. Represent two-digit numbers in different ways by breaking apart and rearranging hundreds, tens, and ones.

## ACTIVITIES

*The time required to complete each activity will vary from student to student. Allow student to move at his/her own pace. If more time is needed, lessons can be carried over to the next tutoring session.*

### **Candy Store**

### **Making Tens – Measuring**

### **Different Ways**

### **Let's Connect**

## MATERIALS ENCLOSED

First to 50 Worksheets (2)

## MATERIALS TO GET

Connecting Cubes (5 bags of one color, 3 bags of a different color, 3 bags of a different color)

Different Ways Worksheet

Let's Connect Packet for  
Place Value

Paper and pencil

## WRAP-UP

- Compliment student for hard work and provide stickers as a reward.
- Discuss with student the lesson goals that were practiced today.
- Ask student two of the following questions on the way back to class:
  - What was hard about today?
  - What did you feel confident about?
  - Where did you see improvement?
  - What do you still need to practice?
  - How do you feel about your effort today?
- Record brief notes on progress log.

## Candy Store

**Materials:** Connecting Cubes (2 blue bags, 2 green bags, 1 red bag), First to 50 Worksheets (2), Pencil and paper

**Purpose:** Student works with cubes to make groups of ten and relates them to the total number.

### Before beginning:

- **Tutor** will put 26 blue Connecting Cubes in one bag, 35 green Connecting Cubes in one bag, and 17 red Connecting Cubes in one bag. (This will require consolidating two bags of cubes for the blue and green). Note: If green, red, and blue cubes are not available please swap with other colors!
- **Student** will create a recording sheet like the one below:

<u>Boxes</u>	<u>Individuals</u>	<u>Total Candies</u>

Together with student, read the following situation and subsequent questions.

**“Congratulations! You have purchased a candy store and are preparing for the grand opening. The candy is shipped to you in bags. Each bag holds a different number of pieces depending on the type of candy. You are going to sell your candy to customers in boxes of ten same colored candies or as individually wrapped pieces. Let’s get ready!”**

Tell student,

**“Place your ‘Blue Blast’ candies on the ten frames to see how many boxes you will need for those candies.”**

Once completed, ask student,

**“How many boxes will you need for ‘Blue Blast’ and how many individuals will you have leftover? How many total pieces of blue candy do you have?”**

Have student record his/her findings on the recording sheet.

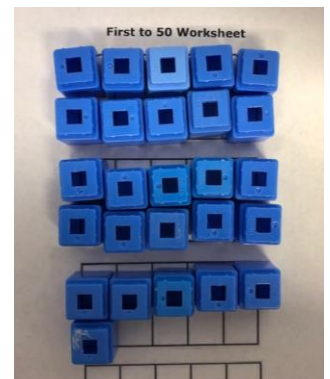

Tell student,

**“Now place your ‘Green Gobstoppers’ candies on the ten frames to see how many boxes you will need for those candies.”**

Once completed, ask student,

**“How many boxes will you need for ‘Green Gobstoppers’ and how many individuals will you have leftover? How many total pieces of green candy do you have?”**

Have student record his/her findings on the recording sheet.

Repeat this process with the “Cherry Chews.”

To ensure understanding, ask student,

**“If you order a bag of ‘Lemon Limes’ with 52 pieces how many boxes would you need and would you have any leftover to sell individually?”**

If student struggles, have them get cubes to represent the candy and place them on the ten frames.

Finally, ask student,

**“If I bought 7 boxes of candy and 6 individual pieces, how many total pieces would I have?”**

HEART MATH TUTORING

## Making Tens - Measuring

**Materials:** Connecting Cubes (3 bags of one color, 3 bags of a different color) / Paper and pencil

**Purpose:** Student works with cubes to make groups of ten and relates them to the total number.

Tell student,

**“Today we are going to practice measuring the length of objects in tens and ones.”**

Make a recording sheet that looks like the following:

<u>Object</u>	<u>Estimate</u>	<u>Actual</u>
Table length	39 (3 tens and 9 ones)	52 (5 tens and 2 ones)

Ask student to select three objects around the room to measure using Connecting Cubes. Ask student to estimate the length and record it before measuring and recording on the recording sheet as shown.

While the student is measuring, ask,

**“Is there a way to keep track of how many tens you have, using the Connecting Cubes?”**

Students may want to change colors with each new group of 10, make every tenth Connecting Cube a different color, arrange each tenth cube differently, etc.

**“Keeping track of the number of tens and ones you have should allow you to know the total number right away.”**

Student should be able to recognize tens as units and know immediately that 3 tens is 30 and 5 tens is 50.

Repeat this for at least three objects.

Ask student,

**“What if a table measurement was 7 tens and 2 ones. Is that the same as 72?”**

If your student seems to struggle with this concept, have them use Connecting Cubes to build the measurement and discover the answer on their own.

## Different Ways

**Materials:** Connecting Cubes (5 bags of the same color) / Different Ways Worksheet / Paper and pencil

**Purpose:** Student practices representing two- and three-digit numbers in different ways by breaking apart and rearranging hundreds, tens, and ones.

Ask student to build 45 with Connecting Cubes, ensuring the groups of ten are stuck together as a ten. (See example below.) Then help student fill out the Different Ways Worksheet, drawing rods and dots to represent tens and ones as shown below. Help them write the "Expanded Form Equation" which shows the value of each digit. (See example below.)

After writing the equation ask,

**"How do your cubes show  $40 + 5$ ?"**

Have student point to his/her cube arrangement.



Different Ways Worksheet		
Number <u>45</u>		
Traditional Way Hundreds	Tens	Ones
		•••••
Traditional Expanded Form Equation $40 + 5 = 45$		

Ask student to re-arrange the cubes, making a different arrangement. Then ask student to fill in the worksheet to match the new arrangement. (See the example below.) Ask student to write the new equation to mirror the new arrangement of cubes.



Different Way 1		
Hundreds	Tens	Ones
		••••• ••••• •••••
Different Way Equation $30 + 15 = 45$		

For the new arrangement, ask the student if the total is the same. For the above example, tutor would ask,

**“Is 3 tens and 15 ones the same as 45?”**

If your student seems to struggle with this concept, have them count out the Connecting Cubes by tens and ones, or by ones to discover this on their own.

Repeat with a *three-digit number* between 115 and 150 using the second side of the Different Ways Worksheet. Tutor may help student build trains of ten to speed up the process.

Example for 136:

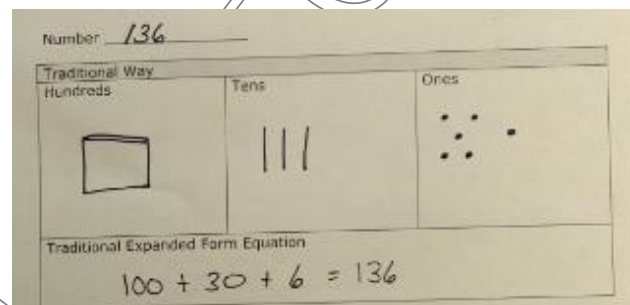
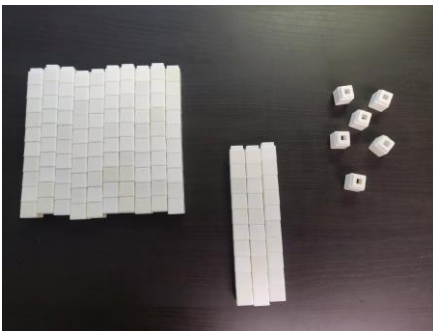

After creating a different arrangement (one example below):

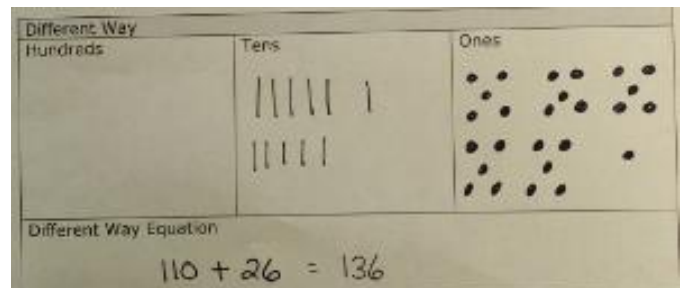

**NOTE:** If student struggles throughout this activity, please make note in Student Progress Log to repeat this activity in the next tutoring session.



## Let's Connect!

**Materials:** Let's Connect Packet for Place Value (*enclosed in Student Progress Folder*) / Word Problem Guide Card (*pink card on cart*) / Paper and pencil

**Purpose:** Student practices standards-aligned content to continue reinforcing and developing skills and concepts.

- 1) Together with student, complete one page (four squares) in the **Let's Connect** Place Value packet.
- 2) For any word problems, use the pink Word Problem Card (*found on the cart*) as a guide for how to talk about and work through the problems in a meaningful way.
- 3) Refer to the orange **Let's Connect** Place Value **Answer Key** (*found on the cart*) to check student work and answers.

## GOALS

*Student will be able to:*

1. Make as many tens as possible and see the leftovers to determine the total.
2. Subtract using known combinations and the underlying structure of tens and ones.

## ACTIVITIES

*The time required to complete each activity will vary from student to student. Allow student to move at his/her own pace. If more time is needed, lessons can be carried over to the next tutoring session.*

### Ten Frame Quick Image Cards

### First to 50 with Ten Frames

### First to Zero with Ten Frames (from 50)

### What's It Worth?

### Let's Connect

## MATERIALS ENCLOSED

First to 50 Worksheets (2)

What's It Worth? Pictures (1-3)

Ten Frame Tornado Cards (1-4)

## MATERIALS TO GET

Connecting Cubes (3 bags of one color, 3 bags of a different color)

Base Ten Cubes (3 bags)

Base Ten Rods (2 bags)

Red Number Cube

Paper and pencil

## IN PROGRESS FOLDER

Let's Connect Packet for  
Place Value

## WRAP-UP

- Compliment student for hard work and provide stickers as a reward.
- Discuss with student the lesson goals that were practiced today.
- Ask student two of the following questions on the way back to class:
  - What was hard about today?
  - What did you feel confident about?
  - Where did you see improvement?
  - What do you still need to practice?
  - How do you feel about your effort today?
- Record brief notes on progress log.

## Ten Frame Quick Image Cards

**Materials:** Ten Frame Tornado Cards (1-4)

**Purpose:** Student practices determining the total by finding the number of tens and ones.

Show student Ten Frame Tornado Card 1 Side 1 for approximately 3 seconds then cover. Ask student,

**“How many tens did you see? How many ones? What was the total number of dots?”**

Complete this activity for all Ten Frame Tornado Cards (showing only one side at a time).

If student struggles, place the Ten Frame Tornado Card on the table and support with questions like those below.

Example for 63:

Ask student,

**“Is there an easy way to see how many tens we have?”** (*eg. two groups of three*)

**“How many dots are in 6 tens?”** (*60*)

**“How many are on the unfilled Ten Frame?”** (*3*)

**“So, what is 60 and 3, or 6 tens and three ones?”** (*63*)

## First to 50 with Ten Frames

**Materials:** Connecting Cubes (3 bags of one color, 3 bags of a different color) / First to 50 Worksheets (2) / Red Number Cube / Paper and pencil

**Purpose:** Student practices creating groups of ten.

Tell student,

**“In the last notebook, Strategies to 20, you learned how to add numbers by making tens and determining the leftovers. Today we are going to play a game that uses the same kind of thinking to help you add larger numbers.”**

**As you know, our number system is based on tens, so keeping our cubes organized into tens will make it easy to see how many we have altogether.”**

Tutor and student both put their own First to 50 Worksheet in front of them. Then they take turns rolling the Red Number Cube (4-9) to determine how many Connecting Cubes to add to their worksheet, placing the cubes into the ten frame squares. The winner of the game is the first to reach 50.

Make sure student pays attention to the need for completing a ten and determining the leftovers. Tutor and student should record their equations and totals on a sheet of paper after each turn. (See Example Recoding Sheet below.)

Once student is comfortable using cubes to determine the total, increase the challenge by asking,

**“Can you use the strategy of thinking about tens and leftovers to predict your new total before putting the cubes on the board?”**

The student must determine whether the number added will complete a ten and if so, what the leftovers will be. Model this way of thinking aloud on your turn. (See Example Response below.)

Example:  $28 + 5$

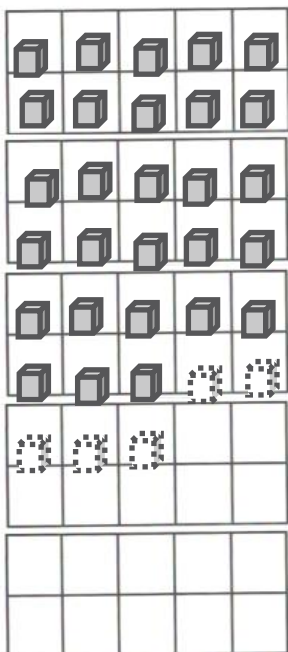

Example Student and Tutor  
Recording Sheets

Student

$0+8=8$   
 $8+7=15$   
 $15+9=24$   
 $24+4=28$

Tutor

$0+7=7$   
 $7+6=13$   
 $13+5=18$   
 $18+9=27$

Example Response  
 $28 + 5$

*“I rolled a 5. I can use 2 to complete a ten and reach 30. I will have 3 left over, so my new score will be 33.”*

After each new total is reached, ask student,

**“How many tens do you have and how many ones? What is the total?”**

**NOTE:** Encourage students to use known combinations rather than counting by ones even when working with single Connecting Cubes.

## First to Zero with Ten Frames (from 50)

**Materials:** Connecting Cubes (3 bags of one color, 3 bags of a different color) / First to 50 Worksheets (2) / Red Number Cube / Paper and pencil

**Purpose:** Student practices subtracting by using the underlying structure of tens and ones.

Tutor and student both put their own First to 50 Worksheet on the table in front of them. Before starting the game, both players place 50 Connecting Cubes on the worksheet filling all five ten frames.

Players take turns rolling the Red Number Cube to determine how many cubes to **remove** from their mats. The winner of the game is the first to clear his/her worksheet.

Make sure student is not counting by ones. Rather, they should use known combinations to remove the cubes. Student should also determine the total left without counting by ones. Model this by thinking out loud on your turn. To elicit this way of thinking ask,

**“How can you break apart the number you rolled to get down to a ten? How many tens and ones do you have left?”**

Model this way of thinking aloud on your turn (See Example Response below.)

Tutor and student should record their equations and totals on a sheet of paper after each turn. (See Example Recording Sheet below.)

Example:  $43 - 7$

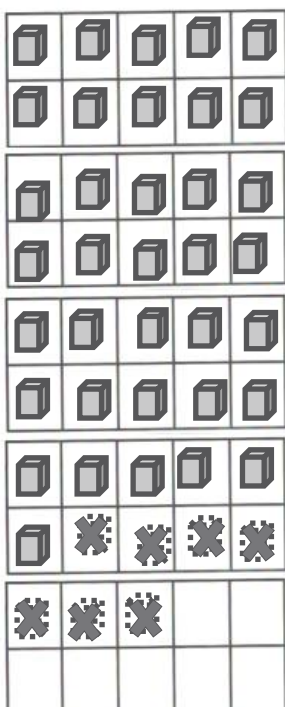

Example Student Recording Sheet

<u>Student</u>	<u>Tutor</u>
$50 - 7 = 43$	$50 - 6 = 44$
$43 - 7 = 36$	$44 - 5 = 39$

Example Response  
 $43 - 7$

*“I rolled a 7. I will take away the 3 ones to get to 40. I still need to take away 4. When I take 4 from one of the tens, I will be left with 6 ones. My new score will be 36.”*

Once student is comfortable with the materials and rules of the game, ask them to *predict* the resulting number before removing cubes from the board. The example above shows use of strategies from the previous concept notebook, Strategies to 20.

**NOTE:** If student struggles throughout this activity, please make note in Student Progress Log to repeat this activity in the next tutoring session.

## What's It Worth?

**Materials:** What's It Worth? Pictures (1-3) / Base 10 Cubes (3 bags) / Base 10 Rods (2 bags) / Paper and pencil

**Purpose:** Student explores what numbers are composed of and practices writing numbers composed of multiple tens and ones.

Tell student,

**“Earlier in this notebook, you completed the Different Ways worksheet and practiced rearranging numbers into tens and ones. Today, we are going to measure pictures using Base Ten Cubes and Rods to determine the “value” of each picture.**

Create a recording sheet that looks like the following:

<i>Shape 1</i>	<i>Estimate: ___ tens, ___ ones Total: _____</i>	<i>Actual: ___ tens, ___ ones Total: _____</i>
<i>Shape 2</i>	<i>Estimate: ___ tens, ___ ones Total: _____</i>	<i>Actual: ___ tens, ___ ones Total: _____</i>
<i>Shape 3</i>	<i>Estimate: ___ tens, ___ ones Total: _____</i>	<i>Actual: ___ tens, ___ ones Total: _____</i>

Place the What's It Worth? Shape 1 on the table and ask student to estimate the “value” of the picture, writing in on the recording sheet. Ask student,

**“How many tens are in your estimate? How many ones? Let's see how close your prediction is!”**

Using Base Ten Cubes and Rods, have student fill in the shape using whichever combination of cubes and rods they choose. When they are finished, have student record the actual value of the shape by combining the total number of tens and ones needed to fill the shape. Ask student,

**“How close was your estimate?”**

**“Is there another combination of cubes and rods you could use to fill the shape?”**

**“Will the value of the shape change with a different combination of tens and ones? Why or why not?”**

Allow student to experiment with different combinations of Base Ten Cubes and Rods to see if they can find another way to fill the shape. The purpose is for the student to practice determining the total when the tens and ones are known, and to see that larger numbers are composed of smaller numbers and that rearranging the tens and ones will not change the total amount.

Repeat activity with What's It Worth Shapes 2 and 3, with both student and tutor making predictions of what each shape is "worth".

HEART MATH TUTORING

## Let's Connect!

**Materials:** Let's Connect Packet for Place Value (*enclosed in Student Progress Folder*) / Word Problem Guide Card (*pink card on cart*) / Paper and pencil

**Purpose:** Student practices standards-aligned content to continue reinforcing and developing skills and concepts.

- 1) Together with student, complete one page (four squares) in the **Let's Connect** Place Value packet.
- 2) For any word problems, use the pink Word Problem Card (*found on the cart*) as a guide for how to talk about and work through the problems in a meaningful way.
- 3) Refer to the orange **Let's Connect** Place Value **Answer Key** (*found on the cart*) to check student work and answers.



## GOALS

*Student will be able to:*

1. Add and subtract groups of tens and ones while exploring number relationships.
2. Mentally add and subtract tens and ones fluently.

## ACTIVITIES

*The time required to complete each activity will vary from student to student. Allow student to move at his/her own pace. If more time is needed, lessons can be carried over to the next tutoring session.*

### **Capture 3**

### **What Numbers Are Missing?**

### **Adding with Expanded Form**

### **Let's Connect**

## MATERIALS ENCLOSED

None

## MATERIALS TO GET

Connecting Cubes (3 bags, each a different color)

Hundreds Chart

+/- Cube

Green Number Cube

Yellow Number Cube

Paper and pencil

What Numbers are Missing  
Worksheet

## IN PROGRESS FOLDER

Let's Connect Packet for  
Place Value

## WRAP-UP

- Compliment student for hard work and provide stickers as a reward.
- Discuss with student the lesson goals that were practiced today.
- Ask student two of the following questions on the way back to class:
  - What was hard about today?
  - What did you feel confident about?
  - Where did you see improvement?
  - What do you still need to practice?
  - How do you feel about your effort today?
- Record brief notes on progress log.

## Capture 3!

**Materials:** 3 bags Connecting Cubes, each different colors / Hundreds Chart / +/- Cube / Yellow Number Cube / Green Number Cube / Pencil and paper

**Purpose:** Student practices mentally adding and subtracting tens and ones using the hundreds chart.

Tell student,

**“The Hundreds Chart is a helpful visual to see what happens when you mentally add and subtract numbers. As you move right along the chart, numbers increase by 1. As you move down the chart, numbers increase by 10.”**

Allow student to confirm that the above is correct.

**We are going to play a game where we will both add and subtract tens and ones on the Hundreds Chart to try and capture cubes. Whoever captures 3 first wins!”**

Have either student or tutor place 12 cubes of one color on the Hundreds Chart so that each cube is on a different number, spread across the chart. Student and tutor then each choose a different color cube – this is their game piece – and place it anywhere on the Hundreds Chart to start.

Student and tutor take turns trying to capture 3 of the 12 cubes on the Hundreds Chart. Moves along the chart are determined by rolling the +/- Cube along with either the Green Number Cube (which determines the tens place) or the Yellow Number Cube (which determines the ones place). If a player lands exactly on one of the 12 cubes, they capture it and removes it from the chart.

With each move, players should say the equation they create.

Example:

After the 12 cubes are placed, Player 1 places their game piece on the “52” square and Player 2 places their game piece on the “35” square.

Player 1 chooses to roll the Green Number Cube (Tens) along with the +/- Cube. Their roll is +3. They say, “52 plus 3 tens is  $52 + 30 = 82$ .” They move their game piece to “82” and capture a piece!

1	■	3	4	5	6	7	8	9	10
■	12	13	14	15	16	17	■	19	20
21	22	23	24	25	26	■	28	29	30
■	32	■	34	P2	36	37	38	39	40
41	42	43	44	45	46	47	48	49	■
51	P1	53	■	55	56	57	58	59	60
61	62	63	64	65	66	67	■	69	70
71	72	73	74	75	■	77	78	79	80
81	■	83	84	85	86	87	88	89	■
91	92	93	94	95	96	97	98	99	100

Player 2 chooses to roll the Yellow Number Cube (Ones) along with the +/- Cube. Their roll is -4. They say, "35 minus 4 ones is 31." They move their game piece to 31 and also capture a cube!

1	■	3	4	5	6	7	8	9	10
■	12	13	14	15	16	17	■	19	20
21	22	23	24	25	26	■	28	29	30
■	32	■	34	P2	36	37	38	39	40
41	42	43	44	45	46	47	48	49	■
51	52	53	■	55	56	57	58	59	60
61	62	63	64	65	66	67	■	69	70
71	72	73	74	75	■	77	78	79	80
81	P1	83	84	85	86	87	88	89	■
91	92	93	94	95	96	97	98	99	100

Player 1 then chooses to roll the Green Number Cube (Tens) along with the +/- Cube. Their roll is -6. They say "82 minus 6 tens is 22 because  $82 - 60 = 22$ ." They move their game piece to "22".

Player 2 chooses to roll the Yellow Number Cube (Ones) along with the +/- Cube. Their roll is -4. They say "I have 31 and I'm taking away 4. I break the 4 into 1 and 3 to subtract. Taking away 1 gets me to 30, then taking away 3 more gets me to 27." They move their game piece to "27".

1	■	3	4	5	6	7	8	9	10
■	12	13	14	15	16	17	■	19	20
21	22	23	24	25	26	27	28	29	30
P2	32	■	34	35	36	■	38	39	40
41	42	43	44	45	46	47	48	49	■
51	52	53	■	55	56	57	58	59	60
61	62	63	64	65	66	67	■	69	70
71	72	73	74	75	■	77	78	79	80
81	P1	83	84	85	86	87	88	89	90
91	92	93	94	95	96	97	98	99	■

Continue playing until one player has captured 3 cubes! If a roll results in an answer greater than 100 or less than 1, roll again.

**Note:** When using the Yellow Number Cubes (Ones), encourage students to use their knowledge of combinations to add and subtract as demonstrated above.

## What Numbers are Missing?

**Materials:** Hundreds Chart (if needed) / What Numbers are Missing Worksheet/ Graph paper and pencil (if needed)

**Purpose:** Student practices adding and subtracting groups of tens and ones while exploring number relationships.

*\*COMPLETE ACTIVITY ON WHAT NUMBERS ARE MISSING WORKSHEET\**

The following images are "pieces" of a Hundreds Chart with blanks where specific numbers belong.

Have your student use mental math to determine the numbers missing. Encourage student to practice adding and subtracting tens without counting by ones. Student may use graph paper to recreate images and solve or simply say the answers aloud.

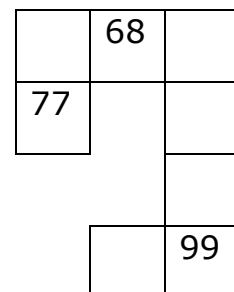
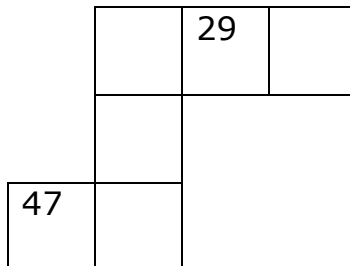
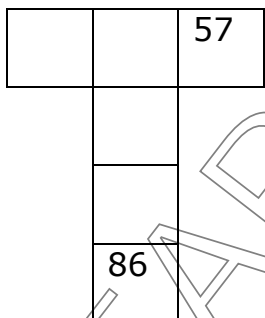
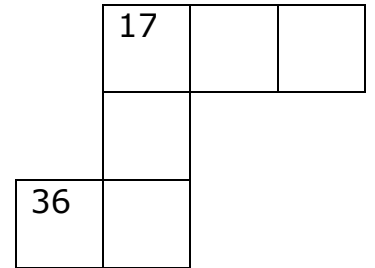
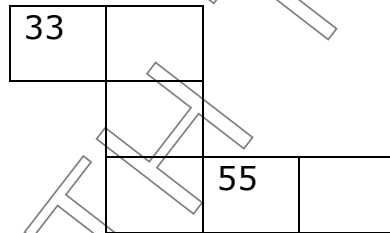
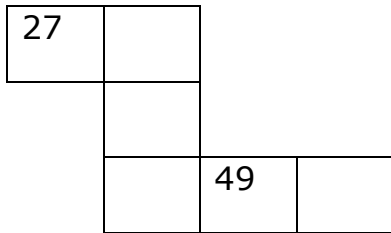

## Adding With Expanded Form

**Materials:** Paper and pencil

**Purpose:** Student practices adding numbers by writing them in expanded form and adding by place.

Tell student,

**“You have used ten frames and mental math to help you add and subtract large numbers by place. Writing numbers in expanded form can be another helpful strategy for doing this. Let’s try this with some examples for adding.”**

For each problem below, refer to pink Word Problem Chart on cart. Solve using Expanded Form.

Example 1:

There are 31 students in Ms. Wright’s class and 25 in Mr. Wilson’s class. If both classes go to Discovery Place together, how many tickets do they need to buy?

Ask student to solve the problem by writing each number in expanded form (breaking them up by place value).

$$\begin{aligned} 31 &= 30 + 1 \\ 25 &= 20 + 5 \end{aligned}$$

Next ask student to combine the tens and the ones to find the answer as shown below. Provide assistance as needed.

$$\begin{array}{r} 31 = 30 + 1 \\ 25 = 20 + 5 \\ \hline 50 + 6 \end{array} = 56 \text{ tickets}$$

**NOTE:** *If student prefers to write numbers in a different format for combining tens and ones, allow them to do so, but model the format above as an option.*

Example 2:

The Charlotte Hornets scored 64 points in the first half of the basketball game and the Chicago Bulls scored 58 points. How many total points were scored in the first half of the basketball game?

Ask student to solve by writing each number in expanded form.

Then ask student to combine the tens and ones to find the total as shown below. Provide assistance as needed.

$$\begin{array}{r} 64 = 60 + 4 \\ 58 = 50 + 8 \\ \hline 110 + 12 \end{array} = 100 + 10 + 10 + 2 = 122$$

**NOTE:** If student prefers to write numbers in a different format for combining tens and ones, allow them to do so, but model the format above as an option.

Additional problems:

Steph is training for a marathon. On Monday she ran 24 miles, and on Tuesday she ran 19. How many miles did she run altogether?

$$24 + 19$$

$$\begin{array}{r} 24 = 20 + 4 \\ \underline{19 = 10 + 9} \\ 30 + 13 = 30 + 10 + 3 = 43 \text{ miles} \end{array}$$

Kayla has 37 dollars and earns 24 more dollars babysitting for a neighbor. How much money does she have altogether?

$$37 + 24$$

$$\begin{array}{r} 37 = 30 + 7 \\ \underline{24 = 20 + 4} \\ 50 + 11 = 50 + 10 + 1 = 61 \text{ dollars} \end{array}$$

Jace owns a car lot with 50 cars and gets 36 more delivered to keep up with demand. How many cars will he have on the lot?

$$50 + 36$$

$$\begin{array}{r} 50 = 50 + 0 \\ \underline{36 = 30 + 6} \\ 80 + 6 = 86 \text{ cars} \end{array}$$

There are 58 homes in Marc's neighborhood and 55 in the neighborhood over. If he wants to put a flyer on each doorstep, how many does he need to make?

$$58 + 55$$

$$\begin{array}{r} 58 = 50 + 8 \\ \underline{55 = 50 + 5} \\ 100 + 13 = 100 + 10 + 3 = 113 \text{ flyers} \end{array}$$

**About Subtracting with Expanded form**

Subtracting with expanded form is possible, but it requires understanding concepts related to positive and negative numbers. Students are typically not introduced to this until middle school. Please tell your student,

**"We can subtract using expanded form, as well, but it can get confusing until you understand positive and negative numbers. For now, this is not a strategy you will want to use."**

## Let's Connect!

**Materials:** Let's Connect Packet for Place Value (*enclosed in Student Progress Folder*) / Word Problem Guide Card (*pink card on cart*) / Paper and pencil

**Purpose:** Student practices standards-aligned content to continue reinforcing and developing skills and concepts.

- 1) Together with student, complete one page (four squares) in the **Let's Connect** Place Value packet.
- 2) For any word problems, use the pink Word Problem Card (*found on the cart*) as a guide for how to talk about and work through the problems in a meaningful way.
- 3) Refer to the orange **Let's Connect** Place Value **Answer Key** (*found on the cart*) to check student work and answers.

## GOALS

*Student will be able to:*

1. Make as many tens as possible and see the leftovers to determine the total.
2. Add and subtract using known combinations and the underlying structure of tens and ones.

## ACTIVITIES

*The time required to complete each activity will vary from student to student. Allow student to move at his/her own pace. If more time is needed, lessons can be carried over to the next tutoring session.*

### **Two-Digit Racing**

### **Adding and Subtracting on a Number Line**

### **Racing Up and Down on the Number Line**

### **Let's Connect**

## MATERIALS ENCLOSED

Place Value Mat (2)

## MATERIALS TO GET

Connecting Cubes (5 bags one color, 5 bags of a different color)

Green Number Cube

Red Number Cube

Paper and pencil

## IN PROGRESS FOLDER

Let's Connect Packet for  
Place Value

## WRAP-UP

- Compliment student for hard work and provide stickers as a reward.
- Discuss with student the lesson goals that were practiced today.
- Ask student two of the following questions on the way back to class:
  - What was hard about today?
  - What did you feel confident about?
  - Where did you see improvement?
  - What do you still need to practice?
  - How do you feel about your effort today?
- Record brief notes on progress log.



## Two-Digit Racing

**Materials:** Connecting Cubes (5 bags of one color, 5 bags of a different color) / Place Value Mat (2) / Green Number Cube / Red Number Cube / Paper and pencil

**Purpose:** Student practices subtracting using the underlying structure of tens and ones.

### Part I: Racing Up!

Each player selects a different color of Connecting Cubes to use and places his/her Place Value Mat on the table. Tutor and student take turns rolling both the Green and Red Number Cubes to determine the number of cubes they will add. The Green Number Cube will represent the tens place and the Red Number Cube will determine the ones place. The winner of the game is the first player to reach 100!

**For each problem ensure student explains his/her thinking.** Student **should not** count up or add cubes one by one. Ensure student is joining cubes into tens and moving them to the "Tens" section of the Place Value Mat when appropriate.

Student and tutor should record the equations on a separate sheet of paper. (See Example Recording Sheet below.)

Example for 25 + 37:

Place Value Mat

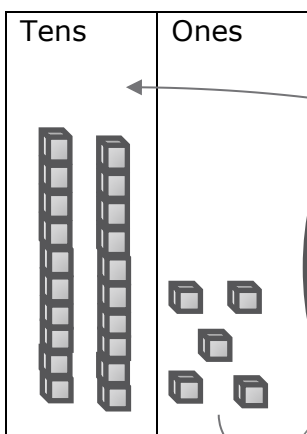

Example Recording Sheet

<i>Student</i>	<i>Tutor</i>
$0 + 25 = 25$	$0 + 19 = 19$
$25 + 37 = 62$	$19 + 28 = 47$
$62 + 23 = 85$	$47 + 15 = 62$

Example Response  
 $25 + 37 = 62$

*"I have 25 and I rolled 37. I will add the three new tens and have 5 tens. Next I will add the 7 ones. I need to use 5 of them to join with the ones I already have and make a new ten. Then I'll have 2 ones leftover. That will leave me with 6 tens and 2 ones, or 62."*

Join to make a new ten and move to the tens place!

Play multiple times, or until your student is comfortable adding and explaining his/her thinking.

**\*Leave your ten stacks of ten when you've completed your final round, as you will use this as the starting point for Part II.\***

## Part II: Racing Down!

Each player begins with ten stacks of ten on the “Tens” side of his/her Place Value Mat. Tutor and student take turns rolling both the Green and Red Number Cubes to determine the number of cubes they will subtract. The Green Number Cube will represent the tens place and the Red Number Cube will determine the ones place. The winner of the game is the first player to reach or pass zero.

**For each problem ensure student explains his/her thinking.** Student may subtract in any way that makes sense to them (taking away tens first or ones first), but student **should not** count backwards or take off cubes one by one. As student is “breaking up” a ten to make ones, ensure they are moving the leftover ones to the “Ones” place on the Place Value Mat.

Student and tutor should record their equations on a separate sheet of paper. (See Example Recording Sheet below.)

Example for 63 - 18:

Place Value Mat

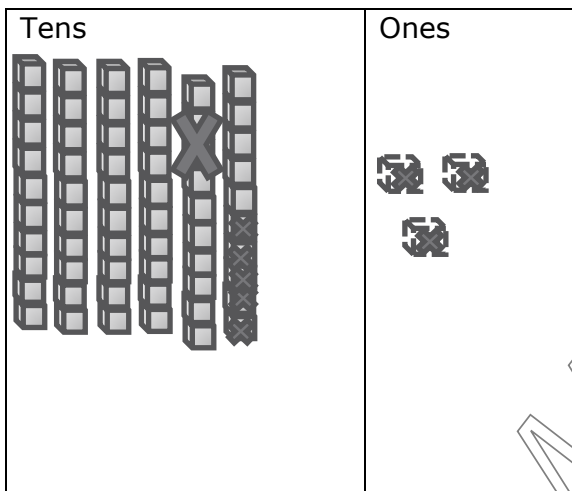

Example Recording Sheet

<u>Student</u>	<u>Tutor</u>
$100 - 21 = 79$	$100 - 34 = 66$
$79 - 16 = 63$	$66 - 23 = 43$
$63 - 18 = 45$	$43 - 9 = 34$

Example Response  
 $63 - 18 = 45$

"I have 63 and I rolled 18. I will take away 3 to get down to 60. Then I will take away the other 5 ones from one of the tens and move them to the ones place. Then I have 55. Now I have to take away the ten, leaving me with 45."

Play multiple times, or until your student is comfortable subtracting and explaining his/her thinking.

**NOTE:** If student struggles throughout this activity, please make note in Student Progress Log to repeat this activity in the next tutoring session.

## Adding and Subtracting on a Number Line

**Materials:** Base Ten Cubes (1 bag) *if needed* / Base Ten Rods (1 bag) *if needed* / Paper and pencil

**Purpose:** Student adds two-digit numbers using the underlying structure of tens and ones.

### Part I: Practicing on the Number Line

Show student an open number line, pictured below or drawn on blank paper. An open number line is an empty line that can be used to find solutions for addition and subtraction problems.



Tell student,

**"You have used Ten Frames and Connecting Cubes to add and subtract numbers up to 100. Now we will use the same ideas, but we will keep track of our thinking using a number line."**

**Example Problem 1:** You are an architect designing a new skyscraper uptown! Your plan needs to include 36 offices and 44 meeting rooms. How many total rooms do you need to include?

Point to the example problem below and say,

**"Here is an example of how a student used an open number line to solve  $36 + 44$ . Look at her work below. Tell me what you see in this example."**

If student is able to clearly explain the picture, move on to the two example problems. If student struggles to explain, read the explanation below.

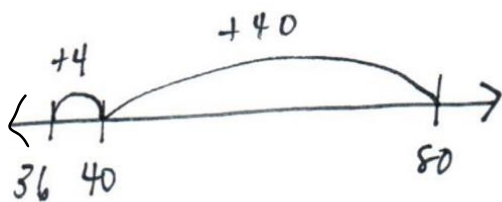

Example Student Recording Sheet

<p><i>Student</i></p> <p><math>36 + 4 = 40</math> <math>40 + 40 = 80</math></p>
-------------------------------------------------------------------------------------

Example Student Response  
 $36 + 44$

<p>"I am at 36. I will add 4 to get to 40, and then I'll have 40 more to add. My total will now be 80."</p>
-------------------------------------------------------------------------------------------------------------

**"This student was adding the 44 conference rooms by moving to the right 44 spaces. However, rather than moving up by ones, she made jumps using parts of 44 that were easy for her to add in her head. Often completing a ten, like on a ten frame, is an easy jump."**

**You do not need to label every number on the number line – only those that you want to use as stopping points. The number line helps us keep track.**

**Once she added 44 conference rooms by moving to the right 44 spaces in jumps of ones and tens, she got to the total number of rooms."**

Ask student,

**"Looking at the example problem of  $36 + 44$ , can you think of another way to solve this with an open number line? What other jumps could the student have made?"**

Allow student to explore other "jumps" that make sense to them. (E.g.,  $36 + 40 = 76$ ,  $76 + 4 = 80$ ;  $36 + 20 = 56$ ,  $56 + 20 = 76$ ,  $76 + 4 = 80$ ; etc.)

Provide the following two example problems for student, ensuring they create both the number line and the numeric representation on the recording sheet. *If student struggles to make logical jumps and/or make new tens, allow them to use Base Ten Cubes and Base Ten Rods to model the problem.*

**Example Problem 2:** Your building uptown has enough space for 80 rooms and you want 36 of them to be offices. How many rooms are left to be meeting rooms?

**Example Problem 3:** Your skyscraper has 80 rooms and the company moving in asks for 44 of them to be meeting rooms. How many leftover rooms can be offices?

## **Part II: Using the Number Line to Solve**

Tell student,

**"We are going to solve the following problems using open number lines. Let's read them together and think about the jumps we can make to solve. For each problem, after you solve I want you to explain to me the jumps you made and why. Remember, there are different ways you can jump and solve."**

**Example Problem 4:** The YouTube video of your puppy chasing the bunny has 37 views and the YouTube video of your brother dancing has 53 views. How many views do your videos have in total?

**Example Problem 5:** You want your TikTok video to reach 70 views. You already have 24 views. How many more views do you need to reach your goal?

**Example Problem 6:** You want to reach 95 followers by the end of summer. As of today, you have 28 followers. How many more followers do you need?

## Racing Up and Down on the Number Line

**Materials:** 1 Green Number Cube (0-4) / 1 Red Number Cube (4-9) / Base Ten Cubes (1 bag) *if needed* / Base Ten Rods (1 bag) *if needed* / Paper and pencil

**Purpose:** Student adds and subtracts two-digit numbers using the underlying structure of tens and ones.

### Part I: Racing Up on the Number Line

Tutor and student each draws their own number line on paper. Student rolls both the Green and Red Number Cubes to determine their starting point on their number line. The Green Number Cube will determine the tens place and the Red Number Cube will determine the ones place. Then tutor rolls to determine their starting point on their number line.

Tutor and student then take turns rolling the cubes to determine the two-digit number they will add to their total (Green will always equal the tens place, Red will always equal the ones place). The winner of the game is the first player to reach or pass 100.

**For each problem, prior to student using number line and solving, ask student to estimate the sum and discuss the reasonableness of their estimate.**

**While solving, ask student to discuss their thinking.** Student *should not* count by ones, but rather use knowledge of combinations and “friendly numbers” (multiples of 5 and 10) when making their number line jumps. In addition to showing the jumps on the number line, ask student to write matching equations on a sheet of paper for each problem they roll and solve.

At several points throughout the game, ask student,

**“About how many do you need to reach 100?”**

Once both players have reached 100, the racing up portion of the game concludes.

### Part II: Racing Down on the Number Line

**Switch to subtraction-** Starting at 100, use the same number cubes and procedures to race to zero. Tutor and student should each use separate sheets of paper to show their jumps on a number line and write the matching equations in numeric form.

At several points throughout the game, ask student,

**“About how many do you need to reach zero?”**

Stop the game when someone reaches zero or rolls a number that will bring them past zero. (\*We will refrain from any discussion with students around negative numbers, as this isn't a foundational concept.)

## Let's Connect!

**Materials:** Let's Connect Packet for Place Value (*enclosed in Student Progress Folder*) / Word Problem Guide Card (*pink card on cart*) / Paper and pencil

**Purpose:** Student practices standards-aligned content to continue reinforcing and developing skills and concepts.

- 1) Together with student, complete one page (four squares) in the **Let's Connect** Place Value packet.
- 2) For any word problems, use the pink Word Problem Card (*found on the cart*) as a guide for how to talk about and work through the problems in a meaningful way.
- 3) Refer to the orange **Let's Connect** Place Value **Answer Key** (*found on the cart*) to check student work and answers.

## GOALS

*Student will be able to:*

1. Make as many tens as possible and see the leftovers to determine the total.
2. Solve multi-digit addition and subtraction problems based on knowledge of place value and parts of numbers.

## ACTIVITIES

*The time required to complete each activity will vary from student to student. Allow student to move at his/her own pace. If more time is needed, lessons can be carried over to the next tutoring session.*

### **Ten Frame Tornado – Addition and Subtraction**

### **Number Line – Adding up to Subtract**

### **Let's Connect**

## MATERIALS ENCLOSED

Ten Frame Tornado Cards (1-4)

## MATERIALS TO GET

Paper and pencil

## IN PROGRESS FOLDER

Let's Connect Packet for  
Place Value

## WRAP-UP

- Compliment student for hard work and provide stickers as a reward.
- Discuss with student the lesson goals that were practiced today.
- Ask student two of the following questions on the way back to class:
  - What was hard about today?
  - What did you feel confident about?
  - Where did you see improvement?
  - What do you still need to practice?
  - How do you feel about your effort today?
- Record brief notes on progress log.



## Ten Frame Tornado – Addition and Subtraction

**Materials:** Ten Frame Tornado Cards (1-4) / Paper and pencil

**Purpose:** Student practices adding by making as many tens as possible and determining the leftovers and adding to find the missing piece.

### PART I: Addition

Tutor folds Ten Frame Tornado Card 1 in half and shows student only Side 1 and asks,

**“You have seen these as ‘Quick Image’ cards before and today we are going to pretend they represent ‘Tornado Pop’ candies at your Candy Store from Lesson 1. If the filled ten frames represent our *boxes* of ten ‘Tornado Pop’ candies, how many candies are shown on Side 1?”**

Once student has determined that the 2 tens and 7 ones is 27, ask,

**“My side has 36 candies. How many candies do we have altogether?”**

Encourage the student to determine how many tens they can make and then to determine how many are left. If the student struggles, unfold the card and allow them to use the visual of ten frames to determine the total number of tens (*boxes of candy*) and ones (*individual candies*). See two examples of student explanations below.

Example for:  $27 + 36$

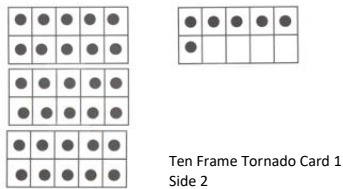

Example Student Response  
 $27 + 36 = 63$

*“27 has 2 tens and 36 has 3 tens, so that’s 5 tens, or 50. Then if I add the 7 ones and 6 ones, I can make 13 (a new ten with 3 left over). That’s 6 tens and 3 ones or 63 candies.”*

OR

*“27 plus 3 more tens is 57. Then I need to add the six ones. 57 plus 3 gets me to 60, then I have 3 left over. That’s 63 candies.”*

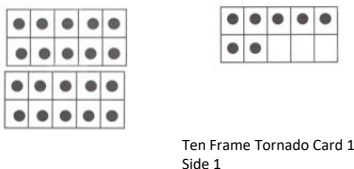

After student has solved the problem, have them write the equation they completed on a recording sheet as shown below. Repeat process with Ten Frame Tornado Card 2, 3 and 4. The goal is at the end of the activity the student can complete the addition problem while the card is folded (with only one addend showing).

Example Student Recording Sheet 

If student struggles, allow them to look at both sides of the Ten Frame Tornado Cards.

Card 1:  $27+36=63$   
Card 2:  $63+34=97$



**PART II: Subtraction**

Tell Student,

**"Now, we're going to answer a different kind of problem with the Ten Frame Tornado Cards. I will tell you the number of candies on side 1 and the total number of candies altogether, then you will have to figure out how many are on side 2."**

**You may find it helpful to think about how many full ten frames (or boxes) are needed first, and then think about the ones (or individuals). "**

Example for Card 1:  $27 + \quad = 63$

Show student Ten Frame Tornado Card 1 Side 1 and ask them to tell you how many candies they see. (27)

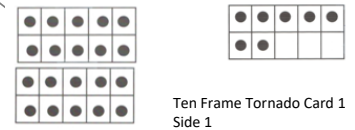

Tell student,

**"There are 27 pieces here, and we need a total of 63 candies at the store. So how many do we need to order for side 2."**

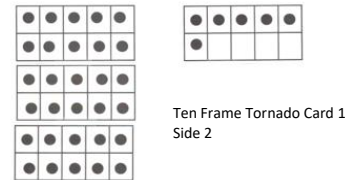

Ask student to write an equation to show what they are trying to figure out:  $27 + ? = 63$   
Then ask them to try and figure it out.

If student struggles, help them by asking how many completed tens (boxes) might be needed.

If student says 4 tens (boxes),

Ask what the total would be if 4 tens were added. (67)

Help student notice that 67 is 4 more than the total needed (63).

See if student can use this information to determine how many candies are on side 2. (36)

If student says 3 tens (boxes),

Ask them to tell the total if 3 tens were added. (57)

Help student notice that 57 is 6 less than 63.

See if student can use this information to determine how many candies are on side 2. (36)

Open Card 1 so student can see all the candies and determine that his/her answer is correct.

Tell student,

**"When you found the missing piece, you determined the answer to a subtraction problem. You figured out 27 plus *what* would give you 63. This answers the same question as 63 minus 27 leaves what."**

After student has solved the problem, have them write the equation they completed on a recording sheet as shown below.

Repeat this process for

Ten Frame Tornado Card 2:  $34 + ? = 97$

Ten Frame Tornado Card 3:  $47 + ? = 76$

Ten Frame Tornado Card 4:  $18 + ? = 92$

If student struggles, allow them to use an open number line to help solve the problems. They would begin with the first addend and make jumps to get to the total. The second addend would be the sum of the jumps taken.

After completing the four cards, review each one by asking student to write the problem that was completed on a separate sheet of paper, *both as an addition equation and as a subtraction equation.*

Example Student  
Recording Sheet

$$\begin{array}{l} \text{Card 1: } 27 + \underline{36} = 63 \\ 63 - 27 = \underline{36} \end{array}$$

$$\begin{array}{l} \text{Card 2: } 34 + \underline{63} = 97 \\ 97 - 34 = \underline{63} \end{array}$$

$$\begin{array}{l} \text{Card 3: } 47 + \underline{29} = 76 \\ 76 - 47 = \underline{29} \end{array}$$

$$\begin{array}{l} \text{Card 4: } 18 + \underline{74} = 92 \\ 92 - 18 = \underline{74} \end{array}$$

**NOTE:** If student struggles throughout this activity, please make note in Student Progress Log to repeat this activity in the next tutoring session.

## Number Line – Adding Up to Subtract

**Materials:** Paper and pencil

**Purpose:** Student practices solving subtraction problems by adding to find the missing piece.

Tell student:

**“In Ten Frame Tornado – Subtraction you found answers to subtraction problems by finding the missing piece. You were given the total number and the number on one side. You then determined how many dots were on the second side. This is called ‘adding up to subtract’ and you can use this method for any subtraction problem.**

**Today we will try some more problems and use a number line to keep track of your thinking.”**

Example:  $65 - 39$

Write  $65 - 39$  on paper and ask student to solve on the Number Line by jumping back to subtract as they have done before. They might jump back 5, jump back 30, and jump back 4 to get the answer, 26. They could also take away 39 using other pieces/jumps. Let student verify that the answer is 26 however they choose.

Tell student,

**“Now we are going to solve the same problem another way. Instead of thinking  $65 - 39 = ?$ , we will think of 65 as the total, and 39 as one of the pieces, so to find the other piece we can solve  $39 + ? = 65$ .”**

Write  $39 + ? = 65$  on paper. Ask student to start at 39 and figure out the distance to 65, moving in jumps/chunks. One possibility (as shown below) would be to add **1** to get to 40 and **20** to get to 60, then **5** to get to 65. The sum of the parts added is **26**.

If student struggles to solve, read the example student response below and ask student to model it on the number line.

After solving, ask student,

**“Can you find all the parts of our equation modeled in our number line drawing? Where is the 65 we started with? Where is the 39? Where is our answer?”**

Ask student to record their method of solving the problem in numeric form as shown below:

Example for 65 - 39:

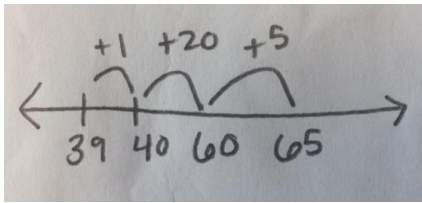

Example Student Recording Sheet

*Student*  
 $39 + 1 = 40$   
 $40 + 20 = 60$   
 $60 + 5 = 65$

Example Student Response

"I am at 39. I will add 1 to get to 40 and then 20 to get to 60. I will then add 5 more to get to 65. That means I added 26 total."

Tell student,

**"Essentially you broke the number 65 into two pieces, 39 and 26. That means that  $65 - 39$  is 26. Another way to look at this connection is to create a fact family, like you've done with smaller numbers. Copy the diagram below onto your own paper and fill it in to represent the way you broke apart 65. Then write the four matching equations below the diagram."**

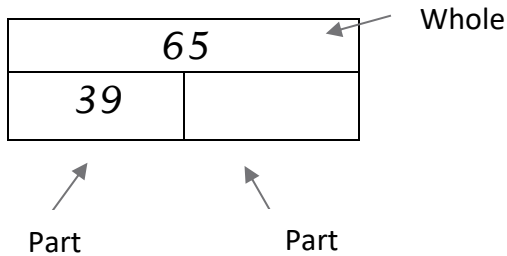

$65 - 39 = 26$   
 $65 - 26 = 39$   
 $26 + 39 = 65$   
 $39 + 26 = 65$

Additional Examples:

For each problem below, ask student to solve by "adding up" on the Number Line and show in numeric form their method of solving. Then have them copy and complete the diagrams below, including the four matching equations.

- 99 - 47
- 112 - 63
- 76 - 49

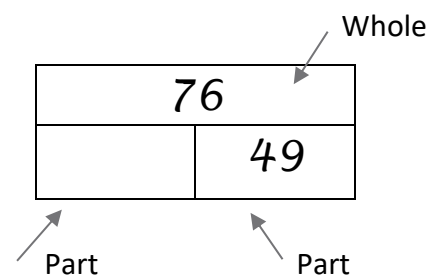
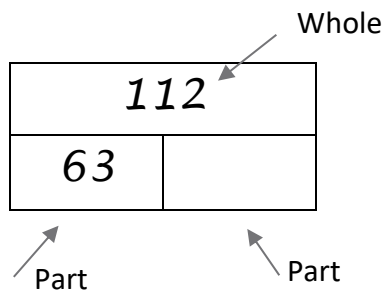
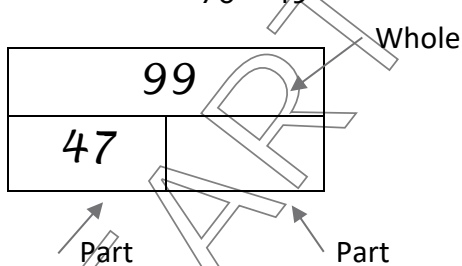

**NOTE:** If student struggles to understand the concept of "adding up" to subtract, move on to the next lesson. This is one of many strategies they can use to subtract and this method does not need to be mastered.

## Let's Connect!

**Materials:** Let's Connect Packet for Place Value (*enclosed in Student Progress Folder*) / Word Problem Guide Card (*pink card on cart*) / Paper and pencil

**Purpose:** Student practices standards-aligned content to continue reinforcing and developing skills and concepts.

- 1) Together with student, complete one page (four squares) in the **Let's Connect** Place Value packet.
- 2) For any word problems, use the pink Word Problem Card (*found on the cart*) as a guide for how to talk about and work through the problems in a meaningful way.
- 3) Refer to the orange **Let's Connect** Place Value **Answer Key** (*found on the cart*) to check student work and answers.

## GOALS

*Student will be able to:*

1. Subtract using knowledge of combinations and the underlying structure of hundreds, tens and ones.
2. Explain his/her solutions in a way that shows understanding of place value.

## ACTIVITIES

*The time required to complete each activity will vary from student to student. Allow student to move at his/her own pace. If more time is needed, lessons can be carried over to the next tutoring session.*

**Friendly Numbers**

**Close to 100**

**Number Squares**

**Let's Connect**

***After completing this lesson, please check with your Program Coordinator to see if your student is ready to move out of 2-digit addition/subtraction.***

## MATERIALS ENCLOSED

### MATERIALS TO GET

Deck of Cards

Paper and pencil

### IN PROGRESS FOLDER

Let's Connect Packet for  
Place Value

## WRAP-UP

- Compliment student for hard work and provide stickers as a reward.
- Discuss with student the lesson goals that were practiced today.
- Ask student two of the following questions on the way back to class:
  - What was hard about today?
  - What did you feel confident about?
  - Where did you see improvement?
  - What do you still need to practice?
  - How do you feel about your effort today?
- Record brief notes on progress log.

## Friendly Numbers

**Materials:** Paper and pencil

**Purpose:** Student practices adding and subtracting a mix of two-digit problems mentally.

### **Part I:**

Ask student,

**“What strategies have you learned so far in Heart for adding and subtracting two-digit numbers?”**

If student struggles, feel free to remind him/her of the following strategies: Base 10 Cubes, Connecting Cubes, Number Line.

Tell student,

**“Today we are going to try solving two-digit problems mentally, without any extra tools. Just like with addition in the Strategies to 20 Notebook, it is helpful to think about making tens and then adding what is leftover. It is easier to add to a ten, or multiples of ten, and that is why we call tens ‘friendly numbers’. Friendly numbers are also easy to add in your head. Let’s try one problem together.”**

Have student write  $38 + 17$  on a sheet of paper. Tell student,

**“38 is close to 40, which is a friendly number. I can move 2 from 17 over to 38, which makes 40. Now, my problem is  $40 + 15$  which is easy to add in my head.  $40 + 15 = 55$ .”**

$$\begin{array}{l}
 38 + 17 = ? \\
 \quad \quad \quad \nearrow 2 \\
 40 + 15 = 55
 \end{array}$$

**“Making a number in the equation “friendly” is another way to approach problem solving in addition to the other strategies you’ve learned. Now it’s your turn to practice!”**

For each problem below, ask student to read the problem and solve mentally. Ensure the student thoroughly explains their thinking while solving. The method should not include the traditional algorithm (carrying and borrowing) or counting by ones.

$25 + 18 =$

$36 + 40 =$

$53 + 17 =$

$83 + 19 =$

**Part II: OPTIONAL (Student may complete the following subtraction strategy as a challenge, but it is not necessary for completing the Place Value Notebook!)**

**“You can also use friendly numbers when subtracting though it is a bit trickier than addition because it involves changing the answer based on how we changed the problem. Let’s try an example together, then we’ll solve the remaining problems as a challenge!”**

Have student write  $57 - 28 =$  on a sheet of paper. Tell student,

**“It is easier to subtract tens from any number so I want to make 28 friendly. I do this by adding 2, making it 30. It is easy to do  $57 - 30$ , which equals 27.**

**However, an equation is like a scale so whatever happens to one side needs to happen to the other for the scale to balance. I added 2 to 28 and so I need to add 2 to the other side of the equation. 27 was on the other side of my equation, so  $27 + 2 = 29$ . The answer to the original problem of  $57 - 28$  is 29.”**

$$57 - 28 = ?$$



$$57 - 30 = 27$$

$$= 29$$

The balancing method only works when changing the second number – the number being subtracted!

With student, solve the following problems using this method. If "changing numbers" does not occur naturally to student, remind them that this is another possible option for solving but assure them that other strategies are fine as well.

$31 - 12 =$

$47 - 38 =$

$73 - 29 =$

$64 - 23 =$



## Close to 100

**Materials:** Deck of Cards / Paper and pencil

**Purpose:** Student practices thinking flexibly about numbers by estimating sums and adding and subtracting two-digit numbers using appropriate strategies.

To begin, tutor removes face cards and tens from the deck and then deals four cards to the student and four to themselves.

The object of the game is for each player's sum to be as "close to 100" as possible. Tutor and student rearrange the cards on the table to make any two two-digit numbers they choose. As new combinations of two-digit numbers to add are created, tutor and student should *estimate* what the answer would be.

Once a player finds a combination of two-digit numbers with an estimated sum that is close to 100, they then find the actual answer by adding using the appropriate strategies (Number Line, Expanded Form, Friendly Numbers) found in this notebook. (See example of explanation via 'Expanded Form' in the Student Response box below.)

A player's score at the end of each round is their distance from 100. Play four rounds, tallying each player's scores on a score sheet as shown below. The person with the lowest score wins.



Example Student Score Sheet:

				Score	
Round 1:	<u>83</u>	+	<u>26</u>	= <u>109</u>	<u>9</u>
Round 2:	<u>    </u>	+	<u>    </u>	= <u>    </u>	<u>    </u>
Round 3:	<u>    </u>	+	<u>    </u>	= <u>    </u>	<u>    </u>
Round 4:	<u>    </u>	+	<u>    </u>	= <u>    </u>	<u>    </u>
	<i>Final Score</i>				<u>    </u>

Example Student Response:

"I added the tens of 80 and 20 to get 100, and the ones, 6 and 3, makes nine. My total is 109 and that is 9 away from 100."

## Number Squares

**Materials:** Paper and pencil

**Purpose:** Student will practice adding and subtracting using the underlying structure of tens and ones.

Each number square has the intended sum of the four digits written underneath it, or a blank where the sum should be.

Have student use mental math to find the number needed in the empty square in order to reach the total, or have them find the total. Ensure the student is combining the numbers by making all of the tens possible and determining leftovers rather than counting by ones.

Example:

2	
4	6

17

Example Student Response:

*"I added 4 and 6 to get 10. Then I added 2 to 10 and that makes 12. I need to get to a total of 17. That means I need to add 5 more to 12. The answer is 5."*

4	
5	7

19

7	8
2	

20

8	3
	6

27

9	
8	3

26

20	
6	3

35

1	5
4	14

\_\_\_\_\_

## Let's Connect!

**Materials:** Let's Connect Packet for Place Value (*enclosed in Student Progress Folder*) / Word Problem Guide Card (*pink card on cart*) / Paper and pencil

**Purpose:** Student practices standards-aligned content to continue reinforcing and developing skills and concepts.

- 1) Together with student, complete one page (four squares) in the **Let's Connect** Place Value packet.
- 2) For any word problems, use the pink Word Problem Card (*found on the cart*) as a guide for how to talk about and work through the problems in a meaningful way.
- 3) Refer to the orange **Let's Connect** Place Value **Answer Key** (*found on the cart*) to check student work and answers.



***Please see your Program Coordinator for a "brain check" to determine if your student is ready to move to the next concept area.***

***For Grades 3-5, this next concept area will be the Multiplication/Division Notebook.***

***After completion of Multiplication/Division, you will then return to this Place Value notebook to finish the remaining lessons in 3-digit addition/subtraction!***

***Thank you!***

## GOALS

*Student will be able to:*

1. Make as many hundreds and tens as possible and see the leftovers to determine the total.
2. Add and subtract three-digit numbers using number relationships.
3. Show understanding by explaining solutions verbally or by demonstrating with cubes, graph paper, a number line, or numeric form.

## ACTIVITIES

*The time required to complete each activity will vary from student to student. Allow student to move at his/her own pace. If more time is needed, lessons can be carried over to the next tutoring session.*

**Hundreds Behind the Curtain**

**Measuring Paper Shapes**

**Adding With Expanded Form**

**Let's Connect**

## MATERIALS ENCLOSED

Measuring Paper Shapes Sheets (1-4)

## MATERIALS TO GET

Base Ten Cubes (2 bags)

Base Ten Rods (1 bag)

Base Ten Squares (1 bag)

Paper Shapes Recording Sheet

Paper and Pencil

## IN PROGRESS FOLDER

Let's Connect Packet for Place Value

## WRAP-UP

- Compliment student for hard work and provide stickers as a reward.
- Discuss with student the lesson goals that were practiced today.
- Ask student two of the following questions on the way back to class:
  - What was hard about today?
  - What did you feel confident about?
  - Where did you see improvement?
  - What do you still need to practice?
  - How do you feel about your effort today?
- Record brief notes on progress log.

## Hundreds Behind the Curtain

**Materials:** Base Ten Cubes (1 bag) / Base Ten Rods (1 bag) / Base Ten Squares (1 bag) / Paper and pencil

**Purpose:** Student practices adding by making as many hundreds and tens as possible.

Verify that student knows that a Base Ten Rod is the same as ten Base Ten Cubes stacked together and that a Base Ten Square is the same as 10 Base Ten Rods stacked together.

**“Today we are going to practice adding by determining how many hundreds we can make, then determining how many tens and ones are left over.”**

Create a recording sheet like the one below.

<i>Hundreds</i>	<i>Tens</i>	<i>Ones</i>	<i>Total</i>

Tutor places 1 Base Ten Square, 13 Base Ten Rods, and 9 Base Ten Cubes behind a sheet of paper that will be used as a “curtain.”

**“I am going to lift the curtain, and I want you to determine the total number of cubes by figuring out how many hundreds, tens, and ones you can make. I’d like you to fill in the recording sheet using the smallest amount of cubes possible.”**

Student should fill out the recording sheet and then determine the total number of cubes that are hiding. They may touch and rearrange the cubes. If the student has not made as many hundreds or tens as possible (i.e. records 13 tens or 21 ones), remind them that the total will remain the same, but it will be easier to determine the total when you have made as many hundreds and tens as possible.

If student struggles, ask **“Do you have enough ones to make another ten? Do you have enough tens to make another hundred?”**

Repeat this activity three times with the following numbers of Base Ten materials:

- 2 Base Ten Squares, 15 Base Ten Rods, and 12 Base Ten Cubes
- 1 Base Ten Square, 17 Base Ten Rods, and 8 Base Ten Cubes
- 2 Base Ten Squares, 11 Base Ten Rods, and 14 Base Ten Cubes

If necessary, provide more examples until student is comfortably able to determine the total by combining the hundreds, tens, and ones.

**NOTE:** If student struggles throughout this activity, please make note in Student Progress Log to repeat this activity in the next tutoring session.

## Measuring Paper Shapes

**Materials:** Measuring Paper Shapes Sheets (1-4) / Base 10 Cubes (2 bags) / Base 10 Rods (1 bag) / Base 10 Squares (1 bag) / Paper Shapes Recording Sheet / Pencil

**Purpose:** Student practices combining and comparing three-digit numbers using knowledge of place value.

Tell student,

**“Today we are going to practice combining (adding) and comparing (finding the difference between) three-digit numbers by keeping track of hundreds, tens, and ones. Measuring paper shapes will give us the values we will combine and compare.”**

Have student fill Shape 1 using any combination of Base 10 Cubes, Rods, and Squares they prefer. Have student record the total number of hundreds, tens, and ones contained in the shape, as well as the total value, on the Paper Shapes Recording sheet. Student may rearrange amounts if he/she prefers (eg, 16 ones is 1 ten and 6 ones.) Repeat with Shape 2.

When both shapes are measured, have student find the combined value of the two shapes by combining the hundreds, then tens, then ones. He/she may use the physical Base Ten blocks to combine or use one of the other strategies he/she has learned thus far (ie; Expanded Form, Number Line).

Next, have student find the difference between the two shapes using the physical Base Ten blocks or using one of the other strategies he/she has learned thus far. Student may keep track of his/her thinking using paper and pencil, if needed.

Example when Combining Shapes:

Shape 1	Shape 2	Combined Value	Difference
Hundreds <u>  1  </u>	Hundreds <u>  1  </u>	Hundreds <u>  2  </u>	Hundreds <u>    </u>
Tens <u>  0  </u>	Tens <u>  6  </u>	Tens <u>  9  </u>	Tens <u>    </u>
Ones <u> 16  </u>	Ones <u> 23  </u>	Ones <u>  9  </u>	Ones <u>    </u>
Total: <u> 116 </u>	Total: <u> 183 </u>	Total: <u> 299 </u>	Total: <u>    </u>

*Tutor: “If Shape 1 has a value of 116 and Shape 2 has a value of 183, what is the combined value of both shapes?”*

*Student: “Each shape has 1 hundred, so combined that is 2 hundreds. Shape 1 has no tens and Shape 2 has 6, so together that is 6 tens. Shape 1 has 16 ones, which is the same as 1 ten and 6 ones. Shape 2 has 23 ones, which is the same as 2 tens and 3 ones. Together, that is 3 tens and 9 ones. When I combine everything I get 2 hundreds, 9 tens, and 9 ones, which is 299.”*

### **Ideas for Comparing Shapes:**

When finding the difference between the two shapes, allow student to explore different strategies that do not include counting or using the traditional algorithm. Strategies include:

- Stacking the Squares, Rods, and Cubes from the smaller image on top of the Squares, Rods, and Cubes from the larger image to see how they are different.
- Finding the difference between the number of hundreds, tens, and ones written on the recording sheet.
- Adding up from the smaller shape to find the difference.

Record the differences between hundreds, tens, and ones on the recording sheet.

Repeat with Shapes 3 and 4.

HEART MATH TUTORING



## Adding With Expanded Form – 3 Digit

**Materials:** Paper and pencil

**Purpose:** Student practices adding numbers by writing them in expanded form and adding by place.

Tell student,

**“You have used expanded form to add two-digit numbers when thinking about tens and ones. Now we will use the same ideas, but with three-digit numbers – so hundreds, tens, and ones.”**

Refer to the pink Word Problem chart on the cart to solve these problems.

Example 1:

Chase has 131 Pokémon cards and Camden has 126 Pokémon cards. How many Pokémon cards do they have in all?

Ask student to solve the problem by writing each number in expanded form (breaking them up by place value).

$$\begin{aligned} 131 &= 100 + 30 + 1 \\ 126 &= 100 + 20 + 6 \end{aligned}$$

Next ask student to combine the hundreds, tens and the ones to find the total as shown below. Provide assistance as needed.

$$\begin{array}{r} 131 = 100 + 30 + 1 \\ 126 = \underline{100 + 20 + 6} \\ 200 + 50 + 7 = 257 \text{ cards} \end{array}$$

**NOTE:** If student prefers to write numbers in a different format for combining hundreds, tens and ones, allow them to do so, but model the format above as an option.

Example 2:

On Saturday, the donut store sold 256 glazed donuts and 145 chocolate donuts. How many donuts did they sell altogether?

Ask student to solve by writing each number in expanded form.

Then ask student to combine the hundreds, tens and ones to find the total as shown below. Provide assistance as needed.

$$\begin{array}{r} 256 = 200 + 50 + 6 \\ 145 = \underline{100 + 40 + 5} \\ 300 + 90 + 11 = 300 + 90 + 10 + 1 = 401 \end{array}$$

**NOTE:** If student prefers to write numbers in a different format for combining tens and ones, allow them to do so, but model the format above as an option.

Additional problems:

Kylin read 157 pages of *Harry Potter* on Monday night and 114 pages on Tuesday night. How many pages did he read altogether?

$$157 + 114$$

$$\begin{array}{r} 157 = 100 + 50 + 7 \\ 114 = 100 + 10 + 4 \\ \hline 200 + 60 + 11 = 200 + 60 + 10 + 1 = 271 \text{ pages} \end{array}$$

Daniel earned 150 points playing Fortnite and Sasha earned 136 points. In total, how many points did they earn?

$$150 + 136$$

$$\begin{array}{r} 150 = 100 + 50 + 0 \\ 136 = 100 + 30 + 6 \\ \hline 200 + 80 + 6 = 286 \text{ points} \end{array}$$

A clothing store sold 354 dresses and 227 jackets in one week. How many items were sold altogether?

$$354 + 227$$

$$\begin{array}{r} 354 = 300 + 50 + 4 \\ 227 = 200 + 20 + 7 \\ \hline 500 + 70 + 11 = 500 + 70 + 10 + 1 = 581 \text{ items} \end{array}$$

Angelica is planning a trip to visit her grandmother. The drive there is 287 miles, and the same distance back. How many miles will she travel altogether?

$$287 + 287$$

$$\begin{array}{r} 287 = 200 + 80 + 7 \\ 287 = 200 + 80 + 7 \\ \hline 400 + 160 + 14 = 400 + 100 + 60 + 10 + 4 = 574 \text{ miles} \end{array}$$

**About Subtracting with Expanded form**

Subtracting with expanded form is possible, but it requires understanding concepts related to positive and negative numbers. Students are typically not introduced to this until middle school. Please tell your student,

**“We can subtract using expanded form, as well, but it can get confusing until you understand positive and negative numbers. For now, this is not a strategy you will want to use.”**

## Let's Connect!

**Materials:** Let's Connect Packet for Place Value (*enclosed in Student Progress Folder*) / Word Problem Guide Card (*pink card on cart*) / Paper and pencil

**Purpose:** Student practices standards-aligned content to continue reinforcing and developing skills and concepts.

- 1) Together with student, complete one page (four squares) in the **Let's Connect** Place Value packet.
- 2) For any word problems, use the pink Word Problem Card (*found on the cart*) as a guide for how to talk about and work through the problems in a meaningful way.
- 3) Refer to the orange **Let's Connect** Place Value **Answer Key** (*found on the cart*) to check student work and answers.

## GOALS

*Student will be able to:*

1. Add and subtract three-digit numbers using number relationships.
2. Solve multi-digit addition and subtraction problems based on knowledge of place value and parts of numbers.
3. Show understanding by explaining solutions verbally or by demonstrating with cubes, graph paper, a number line, or numeric form.

## ACTIVITIES

*The time required to complete each activity will vary from student to student. Allow student to move at his/her own pace. If more time is needed, lessons can be carried over to the next tutoring session.*

### **Adding and Subtracting Three-Digits on the Number Line**

### **Three Digit Word Problems**

### **Let's Connect**

## MATERIALS ENCLOSED

None

## MATERIALS TO GET

Paper and pencil

## IN PROGRESS FOLDER

Let's Connect Packet for  
Place Value

## WRAP-UP

- Compliment student for hard work and provide stickers as a reward.
- Discuss with student the lesson goals that were practiced today.
- Ask student two of the following questions on the way back to class:
  - What was hard about today?
  - What did you feel confident about?
  - Where did you see improvement?
  - What do you still need to practice?
  - How do you feel about your effort today?
- Record brief notes on progress log.

## Adding and Subtracting Three-Digits on the Number Line

**Materials:** Base Ten Squares (1 bag) *if needed* / Base Ten Rods (1 bag) *if needed* / Base Ten Cubes (1 bag) *if needed* / Paper and pencil

**Purpose:** Student adds three-digit numbers using the underlying structure of hundreds tens and ones.

### PART I: Practicing on the Number Line

Tell student,

**"You have used a number line to add up to 100 with two-digit numbers. Now we will use the same ideas, but with three-digit numbers."**

**Example Problem 1:** You own a catering company and are preparing for a large event. The order is for 127 meals with chicken and 115 meals with fish. How many meals do you need to prepare?

Have student write the problem to be answered ( $127 + 115$ ) on paper and help student use an open number line to find the solution.

Ask student to draw an open number line and to label "127" as their starting point.

Explain to student,

**"We will start with 127 meals and add 115 meals by moving to the right 115 spaces. However, rather than moving up by ones, we will make jumps using parts of 115 that are easy for you to add in your head. Often completing a ten, like on a ten frame, is an easy jump."**

**You do not need to label every number on the number line – only those that you want to use as stopping points. The number line helps us keep track.**

**Once you have added 115 by moving to the right 115 spaces, you will be at your answer, which in this case is the total number of meals."**

If student struggles, reference the example below and read aloud the example student response.

Example for  $127 + 115 = ?$

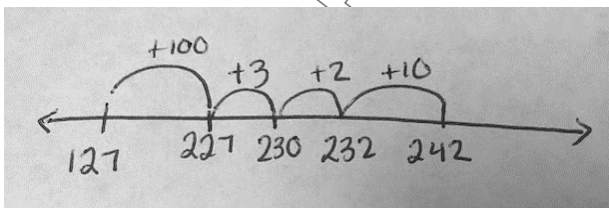

Example Student Recording Sheet

<i>Student</i>
$127 + 100 = 227$
$227 + 3 = 230$
$230 + 2 = 232$
$232 + 10 = 242$

Example Student Response

<p>"I am at 127. I will add 100 to get to 227. Then I will add 3 to get to 230. I have two more ones to add, so I will add 2 to get to 232, and then add the 10 and land on 242."</p>
---------------------------------------------------------------------------------------------------------------------------------------------------------------------------------------

After student completes this first problem, help them connect the written solution with the number line model. Ask student,

**“Where on your number line does it show the 115 meals you added? Where does it show the sum of 127 and 115 (the total number of meals)?”**

**Example Problem 2:** Your event requires 242 meals and you already have 127 pieces of chicken. If the other guests want fish, how many pieces of fish do you need to order?

Have student write the problem to be answered ( $127 + ? = 242$ ) on paper and help student use an open number line to find the solution. Explain this type of subtraction problem can be done on a number line by adding up to find the missing piece or subtracting down.

Adding Up to Subtract: To solve by adding up to subtract, ask student to draw an open number line and to label “127” as their starting point.

Explain to student,

**“We will start with 127 meals and figure out how many we need to add by jumping until we get to 242, our total. We will add together our jumps to find the missing amount, or in the case of our problem, the number of pieces of fish needed.”**

*\*If student recognizes the missing piece will be the same thing they already solved for in previous example, that is okay. Practice using different numbers on this number line to add up to subtract.*

Example for  $127 + ? = 242$ :

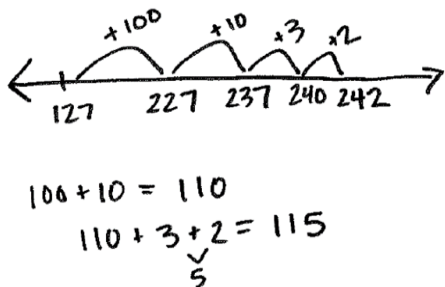

Example Student Recording Sheet

Student

$127 + 100 = 227$   
 $227 + 10 = 237$   
 $237 + 3 = 240$   
 $240 + 2 = 242$

Example Student Response

“I am at 127. I will add 100 to get to 227. I need to get closer to 242, so I will add 10 to get to 237. I am getting close to 242. I will add 3 to get to 240, and then 2 more to get to 242. Now I need to add all of jumps together and I get 115.”

Subtracting Down: To solve by subtracting down, ask student to draw an open number line and to label “242” as their starting point.

Explain to student,

**“This time we are going to subtract by going backwards. We will start with 242, our total meals, and subtract 127, the number we already have. This answer will tell us how many pieces of fish we need.”**

Example for  $242 - 127 = ?$

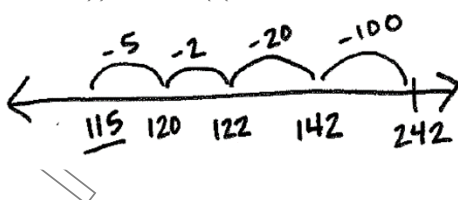

Example Student Recording Sheet

Student

$242 - 100 = 142$   
 $142 - 20 = 122$   
 $122 - 2 = 120$   
 $120 - 5 = 115$

Example Student Response

“I am at 242. I will take away 100 to get to 142. I have 27 left to take, so I will take 20 to get to 122. Next I take 2 more to get to 120. Finally, I will take the last 5 to get to 115.”

Provide the following four additional problems for student, ensuring they create both the number line and the numeric representation on the recording sheet.

If student struggles to make logical jumps and/or make new tens, allow them to use Base Ten Squares, Rods, and Cubes to model the problem.

Before solving each problem, ask student,

**“What is your estimate?”**

Discuss the reasonableness of each estimate before beginning to solve.

Additional Problems:

- At your event, you have 156 guests who do not want dessert and 377 who do want dessert. How many total guests do you have at your event?
- You have 377 plates at your warehouse and you have an event that requires 533. How many more plates do you need to buy?
- You have a photo album with room for 480 photos. So far you have placed 168 photos in the album. How many spots are still empty?
- 312 photos are black and white, and the remaining photos of the 480 are color. How many photos in the album are color photos?
- Bonus question: If you have two identical albums that each hold 480 photos, how many total photos will you need to fill both books?

## Three-Digit Word Problems

**Materials:** Paper and pencil

**Purpose:** Student practices solving a mix of three-digit problems using methods that demonstrate understanding of the structure of hundreds, tens, and ones.

Tell student,

**“For this activity you may select from the ‘menu’ of strategies below.”**

Complete the following steps with student to solve the problems below.

1. Read the problem.
2. Make a rough estimate as to what the answer will be. Record the guess. If student struggles to make a guess, prompt student’s thinking by asking if the difference is above or below various landmark numbers.
3. Solve using a strategy of the student’s choice that demonstrates understanding of place value and parts of numbers. (See Menu of Strategies below.)
4. Explain how they solved the problem and discuss how the final answer compares to the original guess.

<b>Menu of Strategies</b>	
<b>Addition</b>	<b>Subtraction</b>
<ul style="list-style-type: none"> <li>- Adding with Base Ten Cubes, p. 46</li> <li>- Adding (and Subtracting) on a Number Line, p. 26</li> <li>- Friendly Numbers, p. 38</li> <li>- Adding With Expanded Form, p. 48</li> </ul>	<ul style="list-style-type: none"> <li>- Subtracting with Base Ten Cubes, p. 47</li> <li>- (Adding and) Subtracting on a Number Line, p. 26</li> <li>- Number Line – Adding Up to Subtract, p. 34</li> <li>- Friendly Numbers, p.39</li> </ul>

- Jazmine’s father took her to camp and drove 113 miles to get there. Jazmine’s mother took her home a different way and only drove 97 miles. How many miles did Jazmine ride in all, going to and from camp?
- In the problem above, how many fewer miles did Jazmine’s mother drive than her father?
- The fourth grade class keeps track of all the pages they read each month. They read 379 pages in March. They read 185 less pages in April than in March. How many pages did the fourth graders read in April?
- The library had a book fair. It sold 386 children's books. It also sold 158 mystery books. How many books did the library sell altogether?



## Let's Connect!

**Materials:** Let's Connect Packet for Place Value (*enclosed in Student Progress Folder*) / Word Problem Guide Card (*pink card on cart*) / Paper and pencil

**Purpose:** Student practices standards-aligned content to continue reinforcing and developing skills and concepts.

- 1) Together with student, complete one page (four squares) in the **Let's Connect** Place Value packet.
- 2) For any word problems, use the pink Word Problem Card (*found on the cart*) as a guide for how to talk about and work through the problems in a meaningful way.
- 3) Refer to the orange **Let's Connect** Place Value **Answer Key** (*found on the cart*) to check student work and answers.

**GOALS**

*Student will be able to:*

1. Solve a mix of three-digit problems using methods that demonstrate understanding of the structure of hundreds, tens, and ones and require only paper and pencil.

**ACTIVITIES**

*The time required to complete each activity will vary from student to student. Allow student to move at his/her own pace. If more time is needed, lessons can be carried over to the next tutoring session.*

**Rolling Dice to Make Three-Digit Problems****Close to 1,000****Let's Connect****MATERIALS ENCLOSED**

None

**MATERIALS TO GET**

Green Number Cube

Yellow Number Cube

Red Number Cube

+/- Cube

Deck of Cards

Paper and Pencil

**IN PROGRESS FOLDER**Let's Connect Packet for  
Place Value**WRAP-UP**

- Compliment student for hard work and provide stickers as a reward.
- Discuss with student the lesson goals that were practiced today.
- Ask student two of the following questions on the way back to class:
  - What was hard about today?
  - What did you feel confident about?
  - Where did you see improvement?
  - What do you still need to practice?
  - How do you feel about your effort today?
- Record brief notes on progress log.

## Rolling Dice to Make Three-Digit Problems

**Materials:** 1 Green Number Cube (0-4) / 1 Yellow Number Cube (1-6) / 1 Red Number Cube (4-9) / +/- Cube / Paper and pencil

**Purpose:** Student practices three-digit addition and subtraction together using methods of solving that require only pencil and paper.

Tell student,

**“We are going to use Number Cubes to create three-digit addition and subtraction problems. You’ll earn one point for solving the problem and one point for explaining how you solved it. Get ten points to complete this activity! You may only use mental math or blank paper and a pencil to solve each problem.”**

Instruct student to do the following:

Roll all three Number Cubes and use the numbers showing to create a three-digit number.

- The Green Number Cube should determine the digit for the hundreds place.
- Student can choose which digits the other two Number Cubes will determine (tens and ones).

Write the number on paper. Roll the cubes again to determine the second three-digit number, again using the Green Number Cube for the hundreds place.

Roll the +/- Cube to determine whether to construct an addition or subtraction problem. (If subtraction, be sure that student subtracts the smaller number from the larger number.)

1. Make a rough estimate as to what the answer will be. Record the guess. If student struggles to make a guess, prompt student’s thinking by asking if the difference is above or below various landmark numbers.
2. Solve using a strategy of the student’s choice that demonstrates understanding of place value and parts of numbers to earn one point. (See the Menu of Strategies below that now only includes methods that be done mentally or with paper and pencil.)

Ensure student is not simply describing the algorithm.

3. Explain how they solved the problem and discuss how the final answer compares to the original guess to earn a second point.

Repeat the process to create additional problems until student earns ten points! Contact your Program Coordinator for additional assistance if your student struggles with this activity.

<b>Menu of Strategies</b>	
<b>Addition</b>	<b>Subtraction</b>
<ul style="list-style-type: none"> <li>- Adding with Base Ten Cubes, p. 46</li> <li>- Adding (and Subtracting) on a Number Line, p. 26</li> <li>- Friendly Numbers, p. 38</li> <li>- Adding With Expanded Form, p.48</li> </ul>	<ul style="list-style-type: none"> <li>- Subtracting with Base Ten Cubes, p. 47</li> <li>- (Adding and) Subtracting on a Number Line, p.26</li> <li>- Number Line – Adding Up to Subtract, p. 34</li> <li>- Friendly Numbers, p.39</li> </ul>

## Close to 1,000

**Materials:** Deck of Cards / Paper and pencil

**Purpose:** Student practices thinking flexibly about numbers and adding and subtracting three-digit numbers using appropriate strategies.

To begin, tutor removes face cards and tens from the deck and then deals six cards to the student and six to themselves.

The object of the game is for each player's sum to be as "close to 1,000" as possible. Tutor and student rearrange the cards on the table to make any two three-digit numbers they choose. **As new combinations of three-digit numbers to add are created, tutor and student should estimate what the answer would be.**

Once a player finds a combination of three-digit numbers with an estimated sum that is close to 1,000, they then find the actual answer by adding using the appropriate strategies (Number Line, Expanded Form, Friendly Numbers) found in this notebook. (See example of explanation via 'Expanded Form' in the Student Response box below.)

A player's score at the end of each round is their distance from 1,000. Play four rounds, tallying each player's scores on a score sheet as shown below. The person with the lowest score wins.



Example Student Score Sheet:

Example Student Response:

	Score
Round 1: $834 + 256 = 1,090$	<u>90</u>
Round 2: $\underline{\quad} + \underline{\quad} = \underline{\quad}$	<u>        </u>
Round 3: $\underline{\quad} + \underline{\quad} = \underline{\quad}$	<u>        </u>
Round 4: $\underline{\quad} + \underline{\quad} = \underline{\quad}$	<u>        </u>
Final Score	<u>        </u>

"I added the hundreds of 800 and 200 to get 1,000. I added the tens of 30 and 50, which is 80, and then the ones of 6 and 4 will make ten more. 1,000 + 80 + 10, so my total is 1,090. This is 90 away from 1,000 so my score is 90."

## Let's Connect!

**Materials:** Let's Connect Packet for Place Value (*enclosed in Student Progress Folder*) / Word Problem Guide Card (*pink card on cart*) / Paper and pencil

**Purpose:** Student practices standards-aligned content to continue reinforcing and developing skills and concepts.

- 1) Together with student, complete one page (four squares) in the **Let's Connect** Place Value packet.
- 2) For any word problems, use the pink Word Problem Card (*found on the cart*) as a guide for how to talk about and work through the problems in a meaningful way.
- 3) Refer to the orange **Let's Connect** Place Value **Answer Key** (*found on the cart*) to check student work and answers.



Lessons and Activities for

Understanding  
Multiplication and Division  
&  
Multiplication Fluency

*Volunteer Check-Out Materials*

The materials in this notebook are to be used only in conjunction with Heart Math Tutoring. Please contact the administrator of this program before reproducing any materials found in this notebook.



Connecting Students & Volunteers  
for Results that Count

# Understanding Multiplication and Division & Multiplication Fluency

A conceptual understanding of multiplication and division is a prerequisite for learning multiplication combinations fluently. This notebook contains 6 lessons as part of "Understanding Multiplication and Division" to be completed prior to the 7 lessons for "Multiplication Fluency."

Before beginning this concept notebook, check with your Program Coordinator for more information on your student's pre-assessment scores and to find out with which lesson they should start.

# UNDERSTANDING MULTIPLICATION AND DIVISION

## Concept Overview

### CONCEPT GOALS

*Student will be able to:*

1. Solve multiplication problems using objects, drawings, arrays, and skip counting.
2. Solve division problems (sharing and grouping) using objects, drawings, arrays, and the inverse relationship between multiplication and division.
3. Use and interpret multiplication and division notation.
4. Solve and create multiplication and division word problems.

### END OF PROGRAM ASSESSMENT

*Knowing how students will be assessed can help guide instruction.*

**Example 1:** Student will be given a multiplication problem and a division problem and will be asked to solve them. He/she will also be asked to make up a story problem to represent each numeric equation.

**Example 2:** Student will be given multiplication and division story problems and asked to write numeric problems to represent them. He/she will also be asked to solve the problems.

### KEY POINTS

*The information below may assist you in helping your student.*

- Many students who are not fluent with their multiplication combinations lack understanding of the operation itself and what each combination actually means. Students need practice creating, describing, and counting equal groups to internalize this concept.
- Students gain understanding of multiplication through concrete experiences, rather than through work with symbols. The first goal in teaching multiplication is to help students become familiar with the process of multiplication as it appears in the real world – repeated equal groups.
- It is important to provide opportunities for students to work with multiplication and division problems that are related without rushing them to see the relationship between them. The more at ease they become with interpreting the language of multiplication/division and solving problems, the more likely they will be to discover the relationship between the operations.



# UNDERSTANDING MULTIPLICATION AND DIVISION LESSON 1

## GOALS

*Student will be able to:*

1. Solve multiplication problems using objects and drawings.
2. Use and interpret multiplication notation.
3. Solve word problems.

## ACTIVITIES

***Before beginning these activities, check with Program Coordinator to find where in this concept notebook student needs to begin, based on student's pre-assessment scores.***

**Brainstorming Things That Come in Groups**

**Using Counters to Solve Multiplication Story Problems**

**Drawing to Solve Multiplication Story Problems**

**Let's Connect**

## MATERIALS ENCLOSED

None

## MATERIALS TO GET

Connecting Cubes (3 bags of the same color)

Red bowls (10)

Paper and pencil

Let's Connect Packet for Multiplication and Division

## WRAP-UP

- Encourage student to look for objects at home that come in groups and to think of the corresponding multiplication problems.
- Compliment student for hard work and provide stickers as a reward.
- Ask your student two of the following questions on the way back to class:
  - What was hard about today?
  - What did you feel confident about?
  - Where did you see improvement?
  - What do you still need to practice?
  - How do you feel about your effort today?
- Record brief notes on progress log.

## Brainstorming Things that Come in Groups

**Materials:** Paper and pencil

**Purpose:** Introduce student to multiplication by talking about things that come in groups.

Ask student to help brainstorm about things that come in groups. Make a list together, starting with things that come in 2s. (Some possibilities are listed below.)

Groups of 2: eyes, hands, feet, legs, arms, wings, shoes, socks, mittens, wheels on a bike

Groups of 3: sides on a triangle, feet in a yard, wheels on a tricycle

Groups of 4: legs on a dog or cat, sides on a square or rectangle, wheels on a car, legs on a chair

Groups of 5: fingers on a hand, toes on a foot, sides on a pentagon, players on a basketball team, days in a week of school

Groups of 6: legs on insects, sides on a hexagon, 6-pack of soda

Groups of 7: days in a week

Groups of 8: legs on a spider, legs on an octopus, sides on an octagon

Groups of 9: positions on a baseball team

Groups of 10: fingers, toes, dimes in a dollar

Explain to student that he/she will be learning/reviewing how multiplication can be used to count things that come in groups.

Ask student to try solving the problems below:

How many legs do 3 dogs have altogether?

How many days are in 2 weeks?

How many wings do 6 birds have altogether?

How many dimes are in 2 dollars?

Some students will want to draw pictures and count. Others will use repeated addition.

Compliment student for whatever effective strategy he/she uses to determine the correct answers.

## Using Counters to Solve Multiplication Story Problems

**Materials:** Connecting Cubes (3 bags of the same color) / Red bowls (10) / Paper and pencil

**Purpose:** Student uses objects to act out multiplication problems.

Ask student to use Red Bowls and Connecting Cubes as cookies to act out the following multiplication problem:

After school, 4 friends were given a snack. Each friend got 3 cookies in his/her bowl. How many cookies were served in all?

If student struggles, ask questions to prompt thinking. Then explain while writing the corresponding equation on paper:

**"You made 4 groups of 3 cookies, which makes 12 cookies altogether. The multiplication equation that goes with this problem is  $4 \times 3 = 12$ .**

**Counters can represent any object, and you can use bowls to help make groups for any problem, not just problems with food."**

**NOTE:** The standard way to write multiplication problems is to have the first factor represent the number of groups and the second factor represent the number of objects in each group. (This is not something to emphasize with your student but simply a best practice.)

Ask student to use counters and bowls to solve the problems below and to write the corresponding multiplication equations on paper.

Two children took a walk on the beach and picked up shells. Each child found 3 shells. How many shells did they find in all? *Two groups of 3 or  $(2 \times 3)$ .*

Mrs. Johnson gave a bag of oranges to each of her 5 neighbors. Each bag had 4 oranges in it? How many oranges did she give altogether? *Five groups of 4 or  $(5 \times 4)$ .*

Sonja picked 6 flowers to give to her mother. Each flower had 3 petals. How many petals were on all of the flowers? *Six groups of 3 or  $(6 \times 3)$ .*

Explain,

**"The number of groups and the number of objects in each group are called the factors. The total number of objects is called the product. In the multiplication combination  $3 \times 4 = 12$ , 3 and 4 are the factors and 12 is the product."**

Ask student to create his/her own multiplication story problems for the multiplication combinations below. Use the counters and bowls to determine the product for each combination:

2 groups of 9 ( $2 \times 9$ )  
4 groups of 4 ( $4 \times 4$ )  
6 groups of 3 ( $6 \times 3$ )  
2 groups of 7 ( $2 \times 7$ )  
Create more if time permits.

Some students will want to draw pictures and count. Others will use repeated addition or know the multiplication combination. Compliment student for whatever effective strategy he/she uses to determine the correct answers.

## Drawing to Solve Multiplication Story Problems

**Materials:** Connecting Cubes (3 bags of the same color) / Red bowls (7) / Paper and pencil

**Purpose:** Student will not always have access to manipulatives in class. In this activity he/she practices using paper and pencil to model multiplication problems.

Tell student:

**“You have used Connecting Cubes and bowls to keep track of groups for multiplication problems. Now you are going to draw circles and tally marks instead, to keep track of groups.”**

Example:

5 students had 4 pencils in their desks. How many pencils did they have in all?



$$5 \times 4 = 20 \text{ pencils}$$

**“See below for another way to visualize this.”**

Total unknown ?				
4 pencils	4 pencils	4 pencils	4 pencils	4 pencils

Ask student to solve the following problems by drawing and to write the multiplication equation that goes with each one.

**NOTE:** If student has difficulty using tally marks, allow him/her to draw the actual objects. If needed, student may also use cubes to model the problem before drawing it.

There were 3 sailboats. Each of the sailboats had two people on them. How many people were on the sailboats altogether?  $3 \times 2 = 6$  *people*

4 friends walked to the library. Each friend checked out 6 books. How many books did they check out in all?  $4 \times 6 = 24$  *books*

There are 6 tables in the classroom. The art teacher placed 5 crayons on each of the 6 tables. How many crayons did she place on the tables, altogether?  $6 \times 5 = 30$  *crayons*

Xavier had 6 bags of marbles. Each bag had 7 marbles. How many marbles did he have in all?  $6 \times 7 = 42$  *marbles*

### **Creating Multiplication Problems and Drawing to Solve**

Ask student to create his/her own multiplication story problems for the combinations below and to draw circles and tally marks to solve. When solving, be sure to ask for units (e.g. *7 marbles*). Use the words factor and product when discussing with students.

$$3 \times 7$$

$$2 \times 8$$

$$7 \times 10$$

$$4 \times 9$$

## Let's Connect!

**Materials:** Let's Connect Packet for Multiplication & Division (*enclosed in Student Progress Folder*) / Word Problem Guide Card (*pink card on cart*) / Paper and pencil

**Purpose:** Student practices standards-aligned content to continue reinforcing and developing skills and concepts.

- 1) Together with student, complete one page (four squares) in the **Let's Connect** Multiplication and Division packet.
- 2) For any word problems, use the pink Word Problem Card (*found on the cart*) as a guide for how to talk about and work through the problems in a meaningful way.
- 3) Refer to the gray **Let's Connect** Multiplication & Division **Answer Key** (*found on the cart*) to check student work and answers.

# UNDERSTANDING MULTIPLICATION AND DIVISION LESSON 2

## GOALS

*Student will be able to:*

1. Solve multiplication problems using arrays.
2. Use and interpret multiplication notation.
3. Solve word problems.

## ACTIVITIES

*The time required to complete each activity will vary from student to student. Allow student to move at his/her own pace. If more time is needed, lessons can be carried over to the next tutoring session.*

### **Using Rows to Solve Multiplication Story Problems**

### **Solving Multiplication Problems Using Arrays**

### **Let's Connect**

## MATERIALS ENCLOSED

None

## MATERIALS TO GET

Connecting Cubes (3 bags of the same color)

Graph paper (2)

Scissors

Paper and pencil

## IN PROGRESS FOLDER

Let's Connect Packet for  
Multiplication and Division

## WRAP-UP

- Encourage student to look for objects that come in groups at home and to think of the corresponding multiplication problems.
- Compliment student for hard work and provide stickers as a reward.
- Ask your student two of the following questions on the way back to class:
  - What was hard about today?
  - What did you feel confident about?
  - Where did you see improvement?
  - What do you still need to practice?
  - How do you feel about your effort today?
- Record brief notes on progress log.



## Using Rows to Solve Multiplication Story Problems

**Materials:** Connecting Cubes (3 bags of the same color) / Paper and pencil

**Purpose:** Student learns to use rows of counters to represent groups in multiplication problems.

Tell student:

**“Sometimes it is helpful to think about multiplication in a different way – using rows to keep track of groups.”**

Example:

There are 4 rows of cars in the parking lot with 5 cars in each row. How many cars are in the parking lot?



$$4 \times 5 = 20 \text{ cars}$$

Ask student to solve the following problems by making rows of Connecting Cubes and to write the corresponding multiplication equation.

There are 2 rows of chairs with 4 chairs in each row. How many chairs are there altogether?

There are 6 bookshelves, each with 8 books on them. How many books are there in all?

There are 4 rows of desks in the classroom. Each row has 6 desks in it. How many desks are there in all?

Marty bought a box of apples. There were 3 rows of apples in the box. Each row had 10 apples in it. How many apples were in the box altogether?

Explain,

**“You can use rows to model and solve many types of multiplication problems – even ones that may not refer to rows in the problem.”**

Ask student to solve the following problems using rows:

There are 5 bags of pretzels in the pantry. Each bag has 7 pretzels in it. How many pretzels are there altogether? *5 rows of 7* ( $5 \times 7 = 35$  pretzels)

The pet store had 6 cages with 3 hamsters in each. How many hamsters were in the pet store? *6 rows of 3* ( $6 \times 3 = 18$  hamsters)

**Creating story problems and solving with rows:**

Ask student to create his/her own multiplication story problems for the combinations below and to solve them using rows of Connecting Cubes:

$$2 \times 6 =$$

$$6 \times 7 =$$

$$9 \times 3 =$$

$$4 \times 8 =$$

Use the words factor and product when discussing with student.

## Solving Multiplication Problems Using Arrays

**Materials:** Graph paper (2 sheets) / Scissors / Paper and pencil

**Purpose:** Student learns to use arrays to solve multiplication problems and sees how the commutative property ( $3 \times 2 = 2 \times 3$ ) applies to multiplication.

Tell student:

**“We have used rows of cubes to keep track of groups in multiplication problems. Now, we are going to make *arrays* to represent rows.”**

***Arrays can be drawn on graph paper or on plain paper. They are helpful for understanding the properties of multiplication and will later help you know multiplication combinations quickly.***

Read the following problem:

**“There are 6 shelves in the shoe store. Each shelf has 10 shoeboxes on it. How many shoeboxes are there in all?”**

Ask student to use graph paper to draw an array for the problem above. Ask student to count down 6 rows and draw a line and then to count across 10 columns and draw a line. Ask him/her to solve by adding the rows of 10.

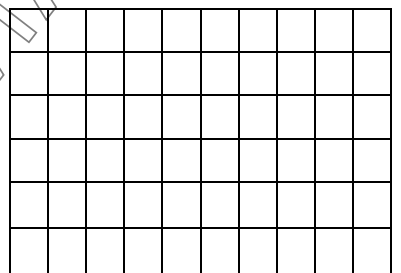

$6 \times 10 = 60$  shoeboxes

Ask:

**“How are arrays the same as thinking about rows of connecting cubes?”** *The empty squares are the same as the cubes.*

Ask student to solve the following related problem by drawing another array on graph paper.

There are 10 shelves in the shoe store. Each shelf has 6 shoeboxes on it. How many shoeboxes are there in all?

Ask student to count down 10 rows and draw a line and then to count across 6 columns and draw a line. Ask him/her to solve by adding the rows of 10.

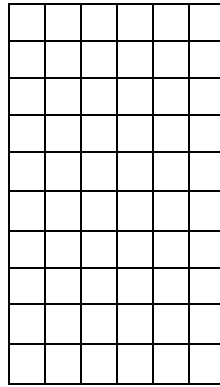

$10 \times 6 = 60$  shoeboxes

Ask student to compare the arrays from the two related problems.

Help him/her see that the arrays are the same but they are turned different ways. He/she may want to cut out the arrays to see this.

Explain,

**"The solution to  $10 \times 6$  is the same as the solution to  $6 \times 10$ . These two problems show the commutative property of multiplication which means that you can switch the order of factors but will still get the same product. (If we know  $4 \times 6 = 24$ , then we also know that  $6 \times 4 = 24$ .)"**

Ask student to solve the following problems by drawing arrays on graph paper and then to compare the arrays for related problems. Encourage him/her to cut out the arrays to show they are equal if needed:

There are 4 rows of cans in the kitchen cabinet. Each row has 7 cans in it. How many cans are there altogether?

There are 7 rows of cans in the kitchen cabinet. Each row has 4 cans in it. How many cans are there altogether? (Remind student that he/she can just turn the first array on its side to model this problem.)

$$4 \times 7 =$$

$$7 \times 4 = \text{(Can be modeled by turning previous array to its side.)}$$

## Let's Connect!

**Materials:** Let's Connect Packet for Multiplication & Division (*enclosed in Student Progress Folder*) / Word Problem Guide Card (*pink card on cart*) / Paper and pencil

**Purpose:** Student practices standards-aligned content to continue reinforcing and developing skills and concepts.

- 1) Together with student, complete one page (four squares) in the **Let's Connect** Multiplication and Division packet.
- 2) For any word problems, use the pink Word Problem Card (*found on the cart*) as a guide for how to talk about and work through the problems in a meaningful way.
- 3) Refer to the gray **Let's Connect** Multiplication & Division **Answer Key** (*found on the cart*) to check student work and answers.

# UNDERSTANDING MULTIPLICATION AND DIVISION LESSON 3

## GOALS

*Student will be able to:*

1. Solve multiplication problems using skip counting.
2. Use and interpret multiplication notation.
3. Solve word problems.

## ACTIVITIES

*The time required to complete each activity will vary from student to student. Allow student to move at his/her own pace. If more time is needed, lessons can be carried over to the next tutoring session.*

### **Skip Counting on Hundreds Charts to See Patterns with Multiples**

### **Skip Counting to Solve Multiplication Problems**

### **Let's Connect**

## MATERIALS ENCLOSED

None

## MATERIALS TO GET

Crayon (any color)

Hundreds Chart (1-100)

Paper and pencil

## IN PROGRESS FOLDER

Let's Connect Packet for  
Multiplication and Division

## WRAP-UP

- Encourage student to look for objects that come in groups at home and to think of the corresponding multiplication problems.
- Compliment student for hard work and provide stickers as a reward.
- Ask your student two of the following questions on the way back to class:
  - What was hard about today?
  - What did you feel confident about?
  - Where did you see improvement?
  - What do you still need to practice?
  - How do you feel about your effort today?
- Record brief notes on progress log.

## Skip Counting on Hundreds Chart to See Patterns with Multiplies

**Materials:** 1 Crayon / 1 Hundreds Chart (1-100) / Paper and pencil

**Purpose:** Student uses skip counting to see overlapping patterns of multiples on the Hundreds Chart.

Tell Student,

**"This activity explores skip counting with different numbers to see how they are related."**

### Skip counting by 2s:

Ask student to count by 2s on the Hundreds Chart and to use a crayon to color in the numbers he/she lands on as shown below. If student is unfamiliar with skip counting, ask him/her to start with 2 and to add 2 each time to determine the next number.

1	2	3	4	5	6	7	8	9	10
11	12	13	14	15	16	17	18	19	20
21	22	23	24	25	26	27	28	29	30
31	32	33	34	35	36	37	38	39	40
41	42	43	44	45	46	47	48	49	50
51	52	53	54	55	56	57	58	59	60
61	62	63	64	65	66	67	68	69	70
71	72	73	74	75	76	77	78	79	80
81	82	83	84	85	86	87	88	89	90
91	92	93	94	95	96	97	98	99	100

Ask,

**"What patterns do you see on the Hundreds Chart?"** *Every other column of numbers is colored in.*

Explain,

**"The colored numbers on the chart are multiples of 2. All numbers that are multiples of 2 are called *Even Numbers*."**

Ask student to skip count by 2s up to 24 without using the chart. If student is unable, ask him/her to do it several times using the chart to help.

### Skip counting by 5s:

Ask student to skip count by 5s and to use a pencil to draw an "X" on multiples of 5. *Student should put an "X" on 5, 10, 15, 20, etc. all the way up to 100.*

Discuss patterns he/she sees. *Numbers ending in 5 and 0 have an X.*

Ask student to skip count by 5s up to 50 without looking at the chart. If student is unable, count together using the chart to help.

### Skip counting by 10s:

Ask student to skip count by 10s and to use a pencil to circle multiples of 10. *Student should circle 10, 20, 30, etc. up to 100.*

Discuss patterns he/she sees. *Numbers ending in 0 are circled.*

Ask student to skip count by 10s to 100 without looking at the chart. If student is unable, count together using the chart to help.

### Compare all of the patterns:

Ask student,

**"What do you notice about how the patterns overlap? Which numbers have more than one marking?"**

1	2	3	4	5	6	7	8	9	10
11	12	13	14	15	16	17	18	19	20
21	22	23	24	25	26	27	28	29	30
31	32	33	34	35	36	37	38	39	40
41	42	43	44	45	46	47	48	49	50
51	52	53	54	55	56	57	58	59	60
61	62	63	64	65	66	67	68	69	70
71	72	73	74	75	76	77	78	79	80
81	82	83	84	85	86	87	88	89	90
91	92	93	94	95	96	97	98	99	100

Close by explaining:

**"In this activity, we skip counted by 2s, 5s, and 10s on the Hundreds Chart. In our next activity, we will use the Hundreds Chart to solve multiplication problems."**

SAVE HUNDREDS CHART FOR USE IN THE NEXT ACTIVITY  
"SKIP COUNTING TO SOLVE MULTIPLICATION PROBLEMS".



## Skip Counting to Solve Multiplication Problems

**Materials:** Hundreds Chart (1-100) (*colored in, from the previous activity*) / Paper and Pencil

**Purpose:** Student uses skip counting to solve multiplication problems.

### Skip Counting by 2s to Solve Multiplication Problems:

Ask student to draw a picture to represent the problem below and to report the answer. Be sure he/she reports the units (e.g. 12 cookies) when telling the answer.

Sam made cookies. She gave 2 cookies to each of her 6 friends. How many cookies did she give her friends altogether?

Explain,

**"Since this problem involves 6 groups of 2, we can solve by adding 2 six times. We could also skip count by 2, six times. Use the Hundreds Chart where you shaded multiples of 2 to find the answer."** Student should move forward on colored squares six times to land on the answer, 12.

**"You can also skip count by 2s using six fingers, saying 2, 4, 6, 8, 10, 12 as you hold up a finger to keep track. This is a quick way to solve multiplication problems. "**

Ask student to use skip counting on his/her fingers to solve the following problems. If student struggles, allow him/her to use the Hundreds Chart (shaded for 2s).

$3 \times 2 =$

$7 \times 2 =$

$10 \times 2 =$

### Skip Counting by 5s to Solve Multiplication Problems:

Ask student to use skip counting by 5s on his/her fingers to solve the following problems. If student struggles, allow him/her to use the Hundreds Chart (marked for 5s).

There are 6 bags of grapes. Each bag has 5 grapes in it. How many grapes are there in all?

$4 \times 5 =$

$8 \times 5 =$

$9 \times 5 =$

### Skip Counting by 10s to Solve Multiplication Problems:

Ask student to use skip counting by 10s on his/her fingers to solve the following problems. If student struggles, allow him/her to use the Hundreds Chart (marked for 10s).

There are 8 friends in the math class. We know that each friend has 10 fingers. How many fingers do they have in all?

$8 \times 10 =$

$10 \times 10 =$

$6 \times 10 =$

## Let's Connect!

**Materials:** Let's Connect Packet for Multiplication & Division (*enclosed in Student Progress Folder*) / Word Problem Guide Card (*pink card on cart*) / Paper and pencil

**Purpose:** Student practices standards-aligned content to continue reinforcing and developing skills and concepts.

- 1) Together with student, complete one page (four squares) in the **Let's Connect** Multiplication and Division packet.
- 2) For any word problems, use the pink Word Problem Card (*found on the cart*) as a guide for how to talk about and work through the problems in a meaningful way.
- 3) Refer to the gray **Let's Connect** Multiplication & Division **Answer Key** (*found on the cart*) to check student work and answers.

# UNDERSTANDING MULTIPLICATION AND DIVISION LESSON 4

## GOALS

*Student will be able to:*

1. Solve division problems (sharing and grouping) using objects.
2. Use and interpret division notation.
3. Solve and create division word problems.

## ACTIVITIES

*The time required to complete each activity will vary from student to student. Allow student to move at his/her own pace. If more time is needed, lessons can be carried over to the next tutoring session.*

**Introducing Division: Acting Out Sharing Problems**

**Introducing Division: Acting Out Grouping Problems**

**Acting Out More Division Problems**

**Let's Connect**

## MATERIALS ENCLOSED

None

## MATERIALS TO GET

Connecting Cubes (3 bags of the same color)

Division Charts (2)

Red bowls (12)

Paper and pencil

## IN PROGRESS FOLDER

Let's Connect Packet for Multiplication and Division

## WRAP-UP

- Encourage student to think about situations at home and at school that involve division problems.
- Compliment student for hard work and provide stickers as a reward.
- Ask your student two of the following questions on the way back to class:
  - What was hard about today?
  - What did you feel confident about?
  - Where did you see improvement?
  - What do you still need to practice?
  - How do you feel about your effort today?
- Record brief notes on progress log.

## Introducing Division: Acting out Sharing Problems

**Materials:** Connecting Cubes (3 bags of the same color) / Division Chart / Red bowls (12) / Paper and pencil

**Purpose:** Student uses objects to solve division problems related to “sharing”.

Tell student,

**“Today we are going to begin division!**

**There are two types of division problems: sharing problems and grouping problems. We will start with some sharing problems and we will use Connecting Cubes to act them out.”**

Example:

You and I are sharing pretzels equally. There are 12 pretzels in all. How many pretzels will each of us get to eat?

Have student use 12 Connecting Cubes (for pretzels) and 2 bowls to act out this problem by dividing (sharing equally) the pretzels between the two of you. He/she will probably know from experience to pass out the “pretzels” (cubes) like dealing cards (one for you, one for me, etc.) until there are 6 pretzels in each bowl.

Tell student,

**“We are going to use a chart to help us keep track of what we know and what we are looking for in the division problems.”**

Using a Division Chart, ask student fill in the information he/she knows from the above problem. Help student see that for this problem, the Number of Items (Objects) in each Group (shaded below) is the unknown that he/she needs to find.

Number In All	Number of Groups	Number of Items (Objects) in each Group	Division Equation	Multiplication Equation
12 pretzels	2 people	?	$12 \div 2 = ?$	(Leave blank for now)

Tell student:

**“We are going to use the Division Chart to do some more problems with pretzels, but this time we will be sharing with more friends. We can use an extra bowl for each friend.”**

If two more friends joined us there would be 4 people in all. If we still have 12 pretzels to split evenly, how many pretzels would each person get? *3 pretzels*

Now, let's say there are 6 people who need to share 12 pretzels evenly. How many pretzels would each person get? *2 pretzels*

What if we have 12 people to share 12 pretzels evenly? How many would each person get? *1 pretzel*

Add these problems to the chart as shown below:

Tell student,

**"We will always use units to ensure we know what we are solving for!"**

Number In All	Number of Groups	Number of Items (Objects) in each Group	Division Equation	Multiplication Equation
12 pretzels	4 people	? 3 pretzels	$12 \div 4 = 3$	(Leave blank for now)
12 pretzels	6 people	? 2 pretzels	$12 \div 6 = 2$	
12 pretzels	12 people	? 1 pretzel	$12 \div 12 = 1$	

Ask student,

**"Do these division problems remind you of multiplication? Can you think of a multiplication equation that goes with the problems?"**

Ask student to fill in the last column of the chart as shown below. If student struggles, ask questions to prompt thinking.

Number In All	Number of Groups	Number of Items (Objects) in each Group	Division Equation	Multiplication Equation
12 pretzels	2 people	? 6 pretzels	$12 \div 2 = 6$	$2 \times \mathbf{6} = 12$
12 pretzels	4 people	? 3 pretzels	$12 \div 4 = 3$	$4 \times \mathbf{3} = 12$
12 pretzels	6 people	? 2 pretzels	$12 \div 6 = 2$	$6 \times \mathbf{2} = 12$
12 pretzels	12 people	? 1 pretzel	$12 \div 12 = 1$	$12 \times \mathbf{1} = 12$

Ask student to create additional division problems involving sharing (dividing equally).

**"Today you have been acting out the *sharing* type of division problem using pretzels and bowls. Can you think of some other sharing problems?"**

If student needs assistance, some possibilities are offered below.

Your father makes 10 cookies that he plans to share equally. How many cookies will each person in your family of 5 get to eat?

Your teacher asks you to divide up 9 pencils evenly among 3 students. How many pencils would each student get?

Ask student to solve his/her problems using Connecting Cubes and bowls and by recording the information in the Division Chart.

HEART MATH TUTORING

## Introducing Division: Acting out Grouping Problems

**Materials:** Connecting Cubes (3 bags of the same color) / Division Chart / Red bowls (12) / Paper and pencil

**Purpose:** Student acts out division problems related to “grouping” and works with remainders.

Tell student,

**“You have solved problems where objects are divided – or shared – evenly into a specific number of groups. We think of those as ‘sharing problems.’ Some problems include creating groups of a specific size and determining how many groups can be made. We think of these as ‘grouping problems,’ and will try some now.”**

Example:  $21 \div 7$

The gym teacher said that each team can have 7 students. How many teams (groups) will there be if the class has 21 students?

Grouping problems are typically harder for students to model. If help is needed, suggest taking 21 cubes (students) and putting 7 of them into bowls (teams) until all cubes are gone.

Ask,

**“How many teams (groups) do you have?”** *Student should have 3 groups of 7.*

Using a Division Chart, ask student to fill in the information he/she knows from the above problem. Help student see that for this problem, the Number of Groups (shaded below) is the unknown that he/she needs to find.

Number In All	Number of Groups	Number of Items (Objects) in each Group	Division Equation	Multiplication Equation
21 students	?	7 students	$21 \div 7 = ?$	$? \times 7 = 21$

**“See below for another helpful way to visualize this type of problem.”**

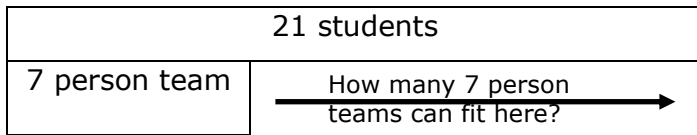

Ask student to fill in the Division Chart for the following problems and to solve using cubes and bowls.

Remind him/her that the cubes can represent any objects, and the bowls can represent any groups.

The classroom has 24 books. There are six books on each shelf. How many shelves are there? *Shelves represent groups of 6.*

Mac has 28 wheels in his Lego set. How many cars can he make using the wheels, assuming each car has 4 wheels? *Cars represent groups of 4.*

15 children are in line to ride the Ferris Wheel at the carnival. 3 of them can fit in each seat. How many seats will they use? *Seats represent groups of 3.*

Number In All	Number of Groups	Number of Items (Objects) in each Group	Division Equation	Multiplication Equation
24 books	? 4 shelves	6 books	$24 \div 6 = ?$	$? \times 6 = 24$
28 wheels	? 7 cars	4 wheels	$28 \div 4 = ?$	$? \times 4 = 28$
15 children	? 5 seats	3 children	$15 \div 3 = ?$	$? \times 3 = 15$

### **Introducing Remainders:**

Ask student to model the following problem:

There are 35 children going on the field trip. 8 children can fit into each van. How many vans will they need?

As student puts 35 children (cubes) in the vans (bowls) by placing 8 cubes in each bowl, he/she will see that 4 vans are full and there are 3 children leftover.

Show student the equation that goes with this *grouping* division problem:  $35 \div 8 = 4 \text{ R } 3$

Discuss the meaning of the answer and ask,

**"How many vans will they need? Are 4 vans enough?"**

*Since there are 3 children leftover, the class will need an extra van. The class needs 5 vans, even though only 4 of the vans are full.*



## Acting Out More Division Problems

**Materials:** Connecting Cubes (3 bags of the same color) / Division Chart / Red bowls (12) / Paper and pencil

**Purpose:** Student practices using objects to solve *sharing* and *grouping* division problems, including problems with remainders.

For each problem below, ask student to fill in the Division Chart and to solve using cubes and bowls. Encourage student to use the visuals under each problem to help make sense of the problem structure.

**NOTE:** Do not be concerned if student has trouble determining which type of division problem he/she is doing. Labeling the problems is not necessary. Student should simply know that sometimes the Number of Items/Objects in each Group is known first and sometimes the Number of Groups is known first.

There are 20 students in gym class and the teacher wants the students to make basketball teams of 5 students each. How many basketball teams can they make?

20 students	
5 person team	?

Alex has 12 pencils and he is going to share them equally with 3 of his friends. How many pencils can each friend have?

12 pencils		
Friend 1 ?	Friend 2 ?	Friend 3 ?

There are 15 cookies left on the plate. If each person takes 3 of them, how many people will get cookies?

15 cookies	
3 cookies	?

Students are using toothpicks to make triangles in math class. There are 18 toothpicks altogether. How many triangles can they make?

18 toothpicks	
Triangle	?

Number In All	Number of Groups	Number of Items (Objects) in each Group	Division Equation	Multiplication Equation
20 students	?	5 students	$20 \div 5 = ?$	$? \times 5 = 20$
12 pencils	3 friends	?	$12 \div 3 = ?$	$3 \times ? = 12$
15 cookies	?	3 cookies	$15 \div 3 = ?$	$? \times 3 = 15$
18 toothpicks	?	3 toothpicks	$18 \div 3 = ?$	$? \times 3 = 18$

### **Creating Story Problems:**

Ask student to make up his/her own division story problems for the following numeric problems:

$$16 \div 2$$

$$20 \div 4$$

$$9 \div 3$$

### **Division Problems with Remainders:**

Ask student to add the following problems to the Division Chart and to solve. Be sure to ask for units:

Janell is using tissue paper to make flowers to give her mother. Each flower is made of 4 pieces of tissue paper. She has 17 pieces in all. How many flowers can she make? Will she have any pieces of tissue leftover? How many? ( $17 \div 4 = 4 R1$ )

Eduardo has \$30 and he wants to buy tickets that cost \$8 each. How many tickets can he buy? Will he have any money left over? How much? ( $30 \div 8 = 3 R6$ )

## Let's Connect!

**Materials:** Let's Connect Packet for Multiplication & Division (*enclosed in Student Progress Folder*) / Word Problem Guide Card (*pink card on cart*) / Paper and pencil

**Purpose:** Student practices standards-aligned content to continue reinforcing and developing skills and concepts.

- 1) Together with student, complete one page (four squares) in the **Let's Connect** Multiplication and Division packet.
- 2) For any word problems, use the pink Word Problem Card (*found on the cart*) as a guide for how to talk about and work through the problems in a meaningful way.
- 3) Refer to the gray **Let's Connect** Multiplication & Division **Answer Key** (*found on the cart*) to check student work and answers.

# UNDERSTANDING MULTIPLICATION AND DIVISION LESSON 5

## GOALS

*Student will be able to:*

1. Solve division problems (sharing and grouping) using objects and drawings.
2. Use and interpret division notation.
3. Solve and create division word problems.

## ACTIVITIES

*The time required to complete each activity will vary from student to student. Allow student to move at his/her own pace. If more time is needed, lessons can be carried over to the next tutoring session.*

### **Drawing to Solve Division Problems**

### **Challenge Practice with Division Chart**

## MATERIALS ENCLOSED

None

## MATERIALS TO GET

Connecting Cubes (3 bags of the same color)

Division Charts (3)

Paper and pencil

## WRAP-UP

- Encourage student to think about situations at home and at school that involve division problems.
- Compliment student for hard work and provide stickers as a reward.
- Ask your student two of the following questions on the way back to class:
  - What was hard about today?
  - What did you feel confident about?
  - Where did you see improvement?
  - What do you still need to practice?
  - How do you feel about your effort today?
- Record brief notes on progress log.

## Drawing to Solve Division Problems

**Materials:** Division Chart / Paper and pencil

**Purpose:** Student will not always have access to manipulatives in class. In this activity, he/she practices drawing circles and tally marks to solve division problems.

Tell student,

**“You have used models to act out two types of division problems. Now, you will draw circles and tally marks instead of using bowls and cubes.**

**We will keep track of the information in the problems with the Division Chart.”**

Example:  $27 \div 9$

Sam made 27 Rice Krispie treats to share evenly with his friends. There were 9 children altogether. How many Rice Krispie treats did each of them get?

Using a Division Chart, help student to enter the information from the problem above.

Number In All	Number of Groups	Number of Items (Objects) in each Group	Division Equation	Multiplication Equation
27 Rice Krispie treats	9 friends	?	$27 \div 9 = ?$	$9 \times ? = 27$

Ask student to model this problem using circle and tally marks as shown below. If help is needed, suggest drawing 9 circles (Children) and then “dealing out” tally marks (Rice Krispie treats) as if playing a card game until 27 tally marks have been made.

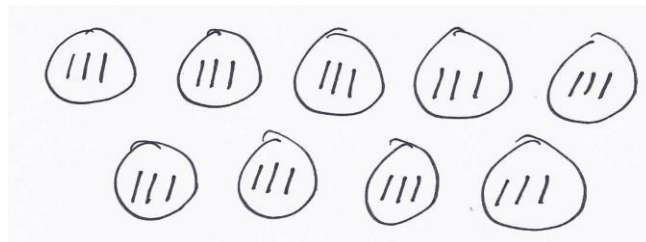

## Additional Problems:

**NOTE:** Student may need help noticing that:

- When the number of groups is known, it is best to start by drawing the groups and then to use tally marks to "deal out" the number in all as you would when playing a game of cards, thus determining the number of items in each group.
- When the number of items in each group is known, student will need to draw all of the objects in one group, then another group, and another group until the number in all is reached, thus determining the number of groups.

The bakery sold 30 cakes in a number of days. If it sold 5 cakes each day, how many days did it take to sell 30?

David picked 12 tomatoes and shared them evenly with 4 neighbors. How many tomatoes did each neighbor receive?

24 girls signed up to play basketball. They need 6 girls on each team. How many teams can they make?

There were 16 books on the table, and the teacher asked John to arrange them in 4 rows. How many books would be in each row?

Number In All	Number of Groups	Number of Items (Objects) in each Group	Division Equation	Multiplication Equation
30 cakes	?	5 cakes	$30 \div 5 = ?$	$? \times 5 = 30$
12 tomatoes	4 neighbors	?	$12 \div 4 = ?$	$4 \times ? = 12$
24 girls	?	6 girls	$24 \div 6 = ?$	$? \times 6 = 24$
16 books	4 rows	?	$16 \div 4 = ?$	$4 \times ? = 16$

## Problems with Remainders

Remind student,

**"Remember that sometimes a quantity cannot be divided equally and some items are left over. The left over amount is called a 'remainder.'"**

Ask student to solve the following problems by filling out the Division Chart and drawing circles and tally marks.

Ms. Jones has 38 flowers. She wants to put them in a bouquet with 6 flowers in each. How many bouquets can she make? Will she have any flowers leftover?  $38 \div 6 = 6 R2$

8 students are sharing 26 crayons. How many crayons will each student get? Are there any crayons left over?  $26 \div 8 = 3 R2$

There are 25 desks in the room. The teacher puts them in groups of 4. How many groups of 4 could she make? Were there any desks left over?  $25 \div 4 = 6 R1$

## Challenge Practice with Division Chart

**Materials:** Division Chart / Connecting Cubes (3 bags of the same color) / Paper and pencil

**Purpose:** Student recognizes multiplication and division in real world context and creates multiplication and division problems.

Ask students to read (aloud) and solve the multiplication/division word problems at the bottom of the lesson.

To earn one point, student must fill in four columns on the Division Chart.

1. Number in All
2. Number of Groups
3. Number of Items in Each Group
4. Either Division Equation OR Multiplication Equation, depending on whether the word problem is a multiplication or division problem.

To earn a second point, student must accurately rephrase the original word problem into a word problem that uses the inverse operation. (i.e., If the original problem involved *multiplication* to solve, student must create a *division* word problem, or vice versa.) Student then fills in the remaining column on the Division Chart.

Connecting Cubes can be used to keep track of points.

Example:

Student reads aloud, "30 pretzels came packaged in 6 bags. Each bag had the same amount of pretzels. How many pretzels were in each bag?"

To earn one point, student fills in chart as shown below:

Number in All	Number of Groups	Number of Items in each Group	Division Equation	Multiplication Equation
30 pretzels	6 bags	? (5 pretzels)	$30 \div 6 = 5$ pretzels	

Be sure student includes units (*bags, pretzels, etc.*) so he/she stays grounded in the real-world context.

To earn a second point, student must create an accurate multiplication question. In multiplication, the product (Number In All) would be the unknown. For example, "There are 6 bags of pretzels, and there are five pretzels in each bag. How many pretzels are there altogether?"

Be sure student's question is clear and accurate. If it is not, help student fix it. (Make sure student earns his/her points!)

Student can now fill in the remaining column and get the second point!

Number in All	Number of Groups	Number of Items in each Group	Division Equation	Multiplication Equation
? (30 pretzels)	6 bags	5 pretzels	$30 \div 6 = 5$ pretzels	$5 \times 6 = 30$ in all

If student struggles and would benefit from modeling, tutor and student can take turns so that tutor can give strong examples of how to understand and create the word problems.

### Word Problems

- Susie makes 4 bracelets with 5 beads each. How many beads did she use to make her bracelets?
- There are 4 flowers in a bunch. How many flowers are there in 5 bunches?
- Mark is fixing drinks for his family for dinner. He has 30 ice cubes and needs to fill 5 glasses with the same number of ice cubes. How many ice cubes does he need to put in each glass?
- Ashley is placing flowers in vases. She bought 30 flowers and put 5 into each vase. How many vases does she use?
- Ross bought 9 packs of highlighters. Each pack has 5 highlighters. How many total highlighters did he buy?
- Phoebe buys 3 packs of jellybeans with a total of 30 jellybeans. How many jellybeans were in each pack?
- Gerald buys 3 new packs of pencils. Each pack has 6 pencils in it. How many pencils does he have?
- Roger collects marbles. He arranges them in 4 rows of 8. How many marbles does he have?
- Chloe buys 4 packs of gumballs for a total of 24 gumballs. How many gumballs are in each pack?
- Mrs. Murphy bought a total of 36 crayons for her classroom. Each pack contains 4 crayons. How many packs of crayons did Mrs. Murphy buy?



# UNDERSTANDING MULTIPLICATION AND DIVISION

## LESSON 6

### GOALS

*Student will be able to:*

1. Solve multiplication problems using objects, drawings, arrays, and skip counting.
2. Solve division problems (sharing and grouping) using objects, drawings, arrays, and the inverse relationship between multiplication and division.
3. Use and interpret division notation.
4. Solve and create division word problems.

### ACTIVITIES

*The time required to complete each activity will vary from student to student. Allow student to move at his/her own pace. If more time is needed, lessons can be carried over to the next tutoring session.*

#### **The Matching Game**

#### **Story Problems**

#### **Find the Error**

***After this lesson is completed, check with the Program Coordinator to determine if student is ready to move on to Multiplication Fluency.***

### MATERIALS ENCLOSED

None

### MATERIALS TO GET

Paper and pencil

### WRAP-UP

- Encourage student to think about situations at home and at school that involve division problems.
- Compliment student for hard work and provide stickers as a reward.
- Ask your student two of the following questions on the way back to class:
  - What was hard about today?
  - What did you feel confident about?
  - Where did you see improvement?
  - What do you still need to practice?
  - How do you feel about your effort today?
- Record brief notes on progress log.

## The Matching Game

**Materials:** Pencil and Paper

**Purpose:** Student practices recognizing multiplication and division scenarios.

Tell student,

**“For this activity you will match a picture to an equation or product on the left. It is helpful to keep in mind that the multiplication symbol ‘x’ means ‘groups of.’ Therefore, the equation  $4 \times 5$  can be read as 4 groups of 5.”**

### Part I:

Ask student to find the equation or product on the left side of the page that matches each image on the right side of the page

$9 \times 2$

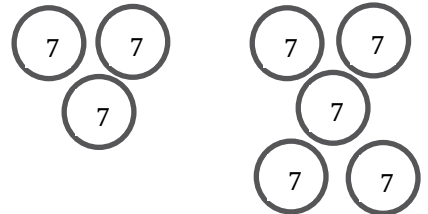

$56$

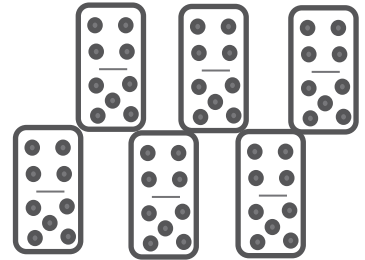

$48 \div 6$



$18 \div 3$

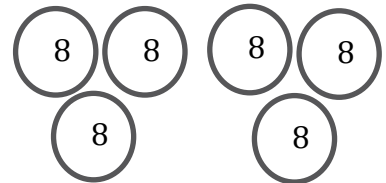

$6 \times 9$

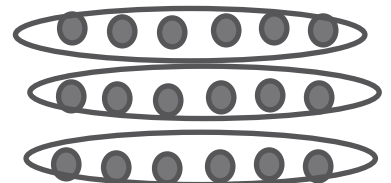

**Part II:**

Ask student to draw an image that matches each of the equations below:

- 1)  $5 \times 6$
- 2)  $21 \div 7$
- 3)  $4 \times 3$
- 4)  $15 \div 5$

***After this lesson is completed, please contact your Program Coordinator.***

HEART MATH TUTORING

## Story Problems

**Materials:** Pencil and Paper

**Purpose:** Student practices recognizing multiplication and division scenarios and creating word problems that represent those situations.

Tell student,

**“For this activity you will look at images and create story problems that match what is happening in each image. Most situations could be either multiplication or division, but it is up to you to decide and then create a correct story problem.”**

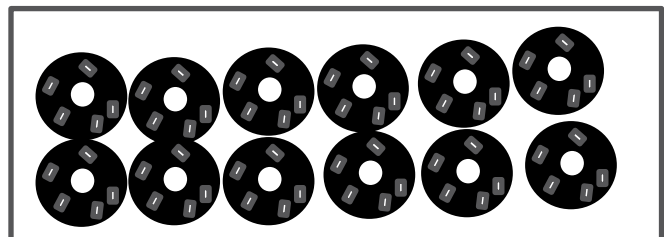
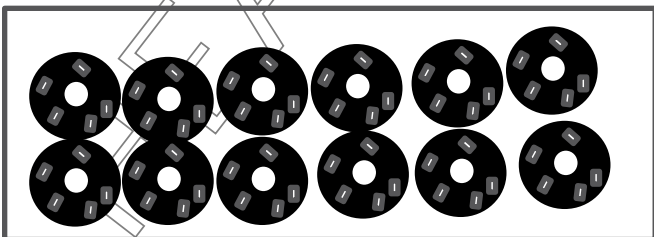
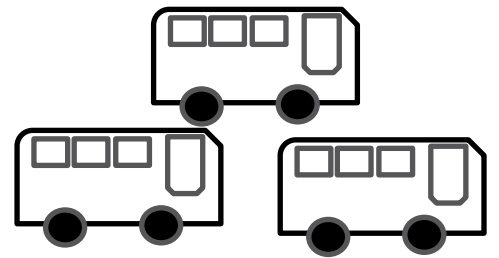
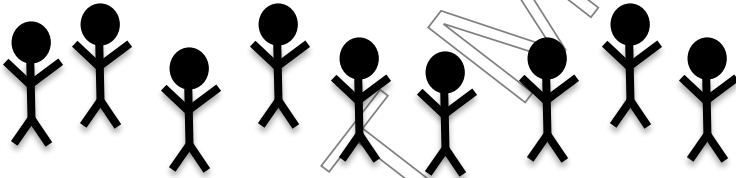
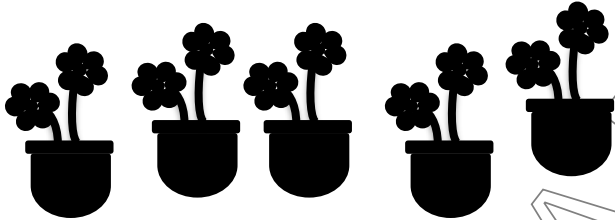
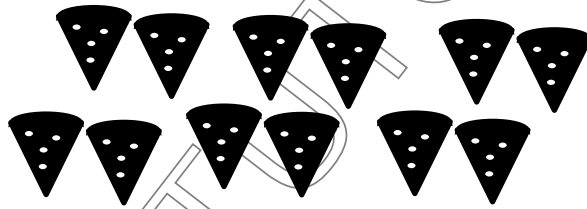
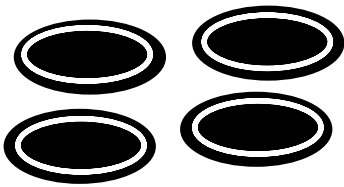

## Find the Error

**Materials:** Paper and Pencil

**Purpose:** Student is able to create and solve word problems that accurately reflect various multiplication and division scenarios.

Some of the problems have errors and others do not! Have student correct the errors in each problem on a separate sheet of paper and then solve.

1. Marcus has 42 cookies and he gives 6 to each friend. How many does each friend get?
2. Karen makes 6 necklaces with 5 beads each. How many beads did she use to make each necklace?
3. Ellen bought 30 flowers. How many flower crowns can she make if she uses 5 flowers for each crown?
4. Mark is fixing drinks for his family for dinner. He has 45 ice cubes and needs to fill 8 glasses with the same number of ice cubes. How many ice cubes does he need to put in each glass?
5. There are 10 chocolates in a box and 7 boxes. How many chocolates are in each box?
6. Ashley is placing flowers in vases. She bought 30 flowers and put 5 into each vase. How many flowers does she need?
7. There are 4 flowers in a bunch. How many flowers are there in 5 bunches?
8. Ross bought 9 packs of pencils. Each pack has 5 pencils. How many total pencils did he buy?
9. Ross divided his highlighters among 3 cups. How many highlighters were in each cup?
10. Emily has 56 pieces of paper. He passes them out to his 8 classmates. How many classmates get paper?
11. Patricia has 20 dollars to spend buying a birthday gift for two friends. How many gifts can she buy?
12. Mia has 15 pieces of train track and wants to create three roads of equal length. How many pieces of track can she use on each road?
13. Carla has 20 hair ties and is fixing four of her cousins' hair for a dance. How many hair ties does she need?

14. There are 4 buckets and 36 seashells. How many seashells are there in all?
15. Michael has 18 pieces of Halloween candy and decides to share with his two sisters. If they split them equally between the three of them, how many pieces does each person get?
16. An auto shop needs to order enough wheels for seven cars. If each car needs 4 wheels, how many cars can they put wheels on?

***After this lesson is completed, please contact your Program Coordinator.***

HEART MATH TUTORING

***Before beginning Lesson 7, please  
see your Program Coordinator!  
He/she will determine if your student  
needs to work in the Fluency portion  
of this notebook. Thank you!***



HEART

## GOALS

*Student will be able to:*

Know from memory or quick reasoning products in Rows 1, 2, 5 and 10 of the multiplication chart using visualization of groups (objects, drawings) and arrays, skip counting, and the commutative property ( $2 \times 4 = 4 \times 2$ ).

## ACTIVITIES

*The time required to complete each activity will vary from student to student. Allow student to move at his/her own pace. If more time is needed, lessons can be carried over to the next tutoring session.*

**Introduce the Multiplication Chart with Numbers 1,2,5, and 10**

**Name the Array and Make Flash Cards (2, 5, 10)**

**Let's Connect**

## MATERIALS ENCLOSED

Multiplication Chart (filled)

Array Cards

## MATERIALS TO GET

Connecting Cubes (1 bag)

Multiplication Chart (blank)

Multiplication Combinations-to-Practice Envelope

Index Cards

Let's Connect Packet for Multiplication and Division

Paper and pencil

## WRAP-UP

- Compliment student for hard work and provide stickers as a reward.
- Ask your student two of the following questions on the way back to class:
  - What was hard about today?
  - What did you feel confident about?
  - Where did you see improvement?
  - What do you still need to practice?
  - How do you feel about your effort today?
- Record brief notes on progress log.



## Introduce the Multiplication Chart with Numbers 1, 2, 5, and 10

**Materials:** Connecting Cubes (1 bag) / Multiplication Chart (blank) / Multiplication Chart (filled) / Paper and pencil

**Purpose:** Student gains exposure to the multiplication chart and begins to notice patterns.

### Part I - Filled Multiplication Chart

Show student a Multiplication Chart (filled) and ask,

**“Have you worked with a chart that looks like this before? What can you tell me about it?”**

Talk about the chart as follows:

**“This Multiplication Chart can help you learn all the multiplication combinations for every number up to  $10 \times 10$ .**

**The numbers going down the left side tell the number of rows or groups you are working with and the numbers at the top tell the number of items in each row or group. These numbers, as you know, are called factors.**

**The numbers in the middle are products.**”

Example for  $2 \times 4$

Pointing at the chart to show student, explain,

**“To find the product for the problem  $2 \times 4$ , (2 groups of 4), you would go down 2 rows and over 4 columns to find the answer, which is 8.”**

Ask student to place cubes on the Multiplication Chart as shown by the shaded area below, filling 2 rows of 4 to see that the total is 8.

X	1	2	3	4	5	6	7	8	9	10
1	1	2	3	4	5	6	7	8	9	10
2	2	4	6	8	10	12	14	16	18	20
3	3	6	9	12	15	18	21	24	27	30
4	4	8	12	16	20	24	28	32	36	40
5	5	10	15	20	25	30	35	40	45	50
6	6	12	18	24	30	36	42	48	54	60
7	7	14	21	28	35	42	49	56	63	70

Repeat for  $5 \times 4$ , asking student to find the answer on the chart, then asking student to place cubes on the chart, filling 5 rows of 4 to see that the total is 20.

## **Part II - Blank Multiplication Chart**

### **About 0**

Ask student,

**“Why do you think there is not a row for “0” on the chart?”**

- *Because 0 groups of any number is always 0, and*
- *Any number of groups with 0 items is always 0*

Have student practice the concept, to ensure it sticks. Ask,

**“How many is 0 groups of 5? How many is 2 groups of 0?  
What is  $0 \times 7$ ? What is  $0 \times 22$ ? What is  $0 \times 1$  million?”**

Tell student,

**“Knowing multiplication combinations quickly is very important and will make it easy for you to do many types of problems in the future.**

**Our goal for the coming weeks will be to learn all of the multiplication combinations for every number up to  $10 \times 10$ .**

**As our first step today, we are going to focus on the combinations for 1, 2, 5, and 10.”**

Use a blank Multiplication Chart for the following:

### **Number 1**

If student knows the answers to the following problems, ask him/her to fill in the chart with the appropriate numbers as shown below. If not, ask student to place cubes in the squares to solve and then to write the answer in the appropriate square.

$1 \times 1 = 1$  row of 1 = 1  
 $1 \times 2 = 1$  row of 2 = 2  
 $1 \times 3 = 1$  row of 3 = 3  
 $1 \times 4 = 1$  row or 4 = 4  
etc.....

	1	2	3	4	5	6	7	8	9	10
1	1	2	3	4	5	6	7	8	9	10
2										
3										
4										

Introduce the Multiplication Chart with Focus Numbers 1, 2, 5 and 10 /  
Multiplication Fluency

## **Number 2**

Ask student to fill in Row 2 of the Multiplication Chart using the same process described above.

X	1	2	3	4	5	6	7	8	9	10
1	1	2	3	4	5	6	7	8	9	10
2	2	4	6	8	10	12	14	16	18	20
3										
4										
5										

When Row 2 is filled in, ask student,

**"What pattern do you notice as you go across Row 2?"**

*Student should notice that the numbers show skip counting by 2s*

## **Number 5**

Ask student to fill in Row 5 of the chart using the above process.

When Row 5 is filled in, ask student,

**"What pattern do you notice as you go across Row 5?"** *Skip counting by 5s.*

**"Do you notice anything else?"** *Every number ends in a 5 or a 0*

**"Can you show me two different ways to find 10 using 2 and 5 as factors on the chart?"**  *$2 \times 5$  and  $5 \times 2$ , as shaded on the chart.*

X	1	2	3	4	5	6	7	8	9	10
1	1	2	3	4	5	6	7	8	9	10
2	2	4	6	8	10	12	14	16	18	20
3										
4										
5	5	10	15	20	25	30	35	40	45	50
6										
7										
8										
9										
10										

## **Number 10**

Repeat the process for filling in Row 10 on the chart.

When Row 10 is filled out, ask student,

**“What pattern do you notice as you go across Row 10?”** *Skip counting by 10’s.*

**“Do you notice anything else?”** *Every number ends in a 0.*

**“Can you show me two different ways to find 20 on the chart, using 2 and 10 as factors?”**  *$10 \times 2$  and  $2 \times 10$*

**“Can you show me two different ways to find 50 on the chart, using 5 and 10 as factors?”**  *$5 \times 10$  and  $10 \times 5$*

<b>X</b>	<b>1</b>	<b>2</b>	<b>3</b>	<b>4</b>	<b>5</b>	<b>6</b>	<b>7</b>	<b>8</b>	<b>9</b>	<b>10</b>
<b>1</b>	1	2	3	4	5	6	7	8	9	10
<b>2</b>	2	4	6	8	10	12	14	16	18	20
<b>3</b>										
<b>4</b>										
<b>5</b>	5	10	15	20	25	30	35	40	45	50
<b>6</b>										
<b>7</b>										
<b>8</b>										
<b>9</b>										
<b>10</b>	10	20	30	40	50	60	70	80	90	100

### **Use the commutative property to fill in opposite combinations:**

Ask student,

**“Since we know  $2 \times 6 = 12$ , is there another combination on the chart we can fill?”**  
*We can fill  $6 \times 2 = 12$ .*

Remind student,

**“We know this because of the commutative property of multiplication.”**

If student does not remember this property, ask him/her to draw a 2 by 6 and a 6 by 2 array (rectangle) on graph paper to see that these hold the same number of squares.

Help student see that because he/she knows how to fill in Rows 1, 2, 5 and 10 on the Multiplication Chart, he/she can also fill in Columns 1, 2, 5 and 10 because of the commutative property. Ask student to fill in these opposite combinations one column at a time.

SAVE PARTIALLY FILLED MULTIPLICATION CHART IN STUDENT PROGRESS FOLDER FOR USE IN NEXT LESSON.

Introduce the Multiplication Chart with Focus Numbers 1, 2, 5 and 10 /  
Multiplication Fluency

## Name the Array and Make Flash Cards (2, 5 and 10)

**Materials:** Array Cards / Multiplication Combinations-to-Practice Envelope (*keep in Student Progress Folder*) / Index Cards / Pencil

**Purpose:** Student practices recalling multiplication combinations with fluency.

**NOTE:** Array Cards are divided by color into combination groups as shown below:

- Yellow=  $2x$ ,  $5x$ ,  $10x$
- Blue=  $4x$
- Green= Squares
- Pink=  $11x$
- White= all remaining combinations

### **Round One: Name the Array**

Since student has only learned combinations for 2, 5, 10, use the yellow Array Cards for this activity.

Mix the array cards and place them in a pile face down on the table.

Turn over the top card and ask student to tell the factors and product as quickly as possible without counting the squares.

If student gets the answer right, he/she keeps the card. If student gets the answer wrong, tutor keeps the card for use in making flash cards and to play Round Two.

Continue turning over cards with student saying the factors and product until all of the cards have been used.

### **Make Flash Cards for combinations that were missed:**

Have student use Index Cards to make flash cards for the combinations he/she missed in Round One. Write the factors both ways on one side (example:  $4 \times 5$  and  $5 \times 4$ ) and write the product on the other side (example: 20). Drawing the array is not necessary.

Place these cards in student's Multiplication Combinations-To-Practice Envelope and keep in his/her Progress Folder for practice in later lessons until he/she knows the combinations with consistency.

### **Round Two: Name the Array**

Use the array cards for the missed combinations in Round One to play the game again.

*If student knows all the combinations quickly, move ahead and begin the next Lesson.*

*If student needs more work on these combinations, replay this game and/or use the flash cards to review.*

## Let's Connect!

**Materials:** Let's Connect Packet for Multiplication & Division (*enclosed in Student Progress Folder*) / Word Problem Guide Card (*pink card on cart*) / Paper and pencil

**Purpose:** Student practices standards-aligned content to continue reinforcing and developing skills and concepts.

- 1) Together with student, complete one page (four squares) in the **Let's Connect** Multiplication and Division packet.
- 2) For any word problems, use the pink Word Problem Card (*found on the cart*) as a guide for how to talk about and work through the problems in a meaningful way.
- 3) Refer to the gray **Let's Connect** Multiplication & Division **Answer Key** (*found on the cart*) to check student work and answers.

*Students who have strong knowledge of these combinations will move through these activities quickly and should move on to the next lesson.*

## ACTIVITIES

### Focus on 4

**Fill in the Multiplication Chart (Review for 1, 2, 5, 10, and 4)**

**War with Array Cards**

**Let's Connect**

## MATERIALS ENCLOSED

Array Cards

## MATERIALS TO GET

Graph paper

Paper and pencil

Multiplication Chart (blank)

## IN PROGRESS FOLDER

Multiplication Chart (partially filled  
from Lesson 7)

Let's Connect Packet for  
Multiplication and Division

## WRAP-UP

- Make 2 or 3 "take-home" flash cards for combinations student is working on. Encourage student to review and practice these at home.
- Compliment student for hard work and provide stickers as a reward.
- Ask your student two of the following questions on the way back to class:
  - What was hard about today?
  - What did you feel confident about?
  - Where did you see improvement?
  - What do you still need to practice?
  - How do you feel about your effort today?
- Record brief notes on progress log.

## Focus on 4

**Materials:** Multiplication Chart (*partially filled from Lesson 7 - saved in Student Progress Folder*) / Graph paper / Pencil

**Purpose:** Student practices solving multiplication problems with 4 as a factor.

### **Filling in the Multiplication Chart**

Ask student to fill in Row 4 of the multiplication chart using whatever method he/she chooses to figure out the products. Some possible methods are below:

- Skip counting by 4s
- Adding the rows of the combination array
- Just knowing the answer
- Other (Ask student to explain.)

Ask student,

**“What do you notice about the numbers in Row 4 compared to the numbers in Row 2?”** *They are double (or two times) the number in Row 2.*

Explain,

**“When a number is multiplied by 2, it is doubled once. And when a number is multiplied by 4, it is doubled twice. Knowing this can be a helpful tool when multiplying by 4.”**

Let student try the process of doubling twice with the following problems:

$4 \times 3 = ?$	$3 + 3 = 6$	and	$6 + 6 = 12$
$4 \times 5 = ?$	$5 + 5 = 10$	and	$10 + 10 = 20$
$4 \times 6 = ?$	$6 + 6 = 12$	and	$12 + 12 = 24$
$4 \times 10 = ?$	$10 + 10 = 20$	and	$20 + 20 = 40$



## Draw Arrays

Ask student to use graph paper to draw the array for  $4 \times 8 = 32$ .

Then ask student to draw a line through the middle as shown below and help him/her label the two parts.

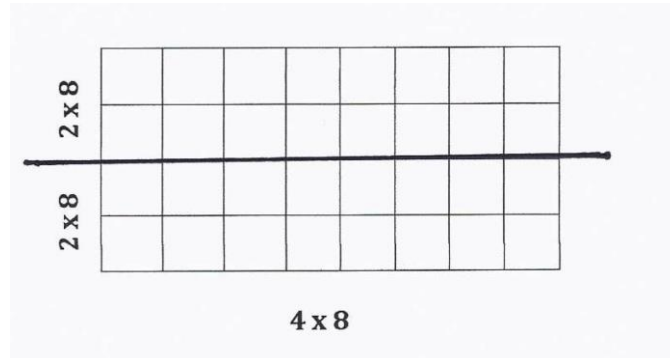

Tell student:

**"The array is another way to see that  $4 \times 8$  is the same as  $(2 \times 8) + (2 \times 8)$ .**

**Breaking a factor into parts is often a good way to find products for larger numbers."**

Repeat with  $4 \times 5$ , which would look like  $(2 \times 5) + (2 \times 5)$  when a line is drawn through the middle.

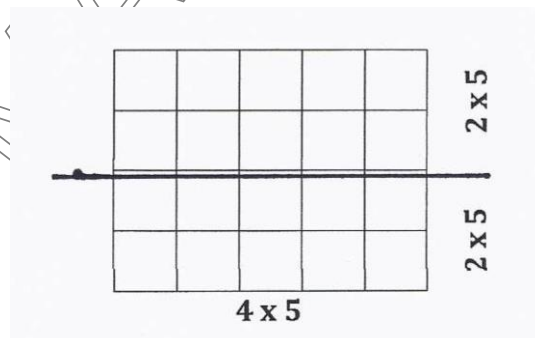

Repeat with  $4 \times$  a number less than 10 of the student's choice.

*PLEASE DISCARD PARTIALLY FILLED MULTIPLICATION CHART.*

## Fill in the Multiplication Chart (Review for 1, 2, 5, 10 and 4)

**Materials:** Multiplication Chart (blank) / Graph paper / Pencil

**Purpose:** Student practices recalling multiplication combinations using the Multiplication Chart.

Ask student to fill in Rows 1, 2, 4, 5, and 10 of the Multiplication Chart as quickly as he/she is able.

Also, ask student a few of the 0s combinations to double-check that he/she has mastered those.

### **Use the commutative property to fill in opposite combinations:**

Ask student,

**“Since we know  $4 \times 6 = 24$ , is there another combination on the chart we can fill?”**  
*We can fill  $6 \times 4 = 24$ .*

Remind student,

**“We know this because of the commutative property of multiplication.”**

Help student see that because he/she knows how to fill in Rows 1, 2, 4, 5 and 10 on the Multiplication Chart, he/she can also fill in Column 1, 2, 4, 5 and 10 because of the commutative property. Ask student to fill in these opposite combinations in each of those columns.

*SAVE PARTIALLY FILLED MULTIPLICATION CHART IN STUDENT'S PROGRESS LOG TO USE IN NEXT LESSON.  
(Previously saved charts can be discarded.)*

## War with Array Cards

**Materials:** Array Cards

**Purpose:** Student practices recalling multiplication facts with fluency.

**NOTE:** Array Cards are divided by color into combination groups as shown below:

- Yellow=  $2x$ ,  $5x$ ,  $10x$
- Blue=  $4x$
- Green= Squares
- Pink=  $11x$
- White= all remaining combinations

Since student has only learned combinations for 2, 5, 10, and 4, use the yellow and blue Array Cards for this activity.

Split the cards evenly between two players.

Both players turn over their top cards. Each player must say the product (answer) of his/her card. Use the words factor and product to reinforce vocabulary.

The player with the higher product takes both cards.

If the two players have equal products, both players turn over a second card to "beat the tie".

Continue until there are no more cards to turn over. The game can end here with the player holding the most cards as the winner.

Example cards

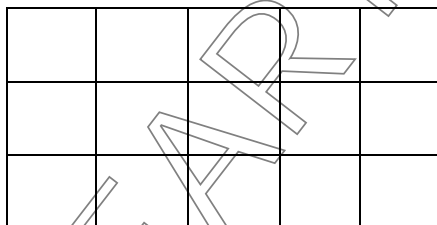

**$3 \times 5$**

**$5 \times 3$**

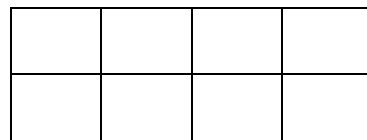

**$2 \times 4$**

**$4 \times 2$**

*"My product is 15 and your product is 8, so I take these cards."*

## Let's Connect!

**Materials:** Let's Connect Packet for Multiplication & Division (*enclosed in Student Progress Folder*) / Word Problem Guide Card (*pink card on cart*) / Paper and pencil

**Purpose:** Student practices standards-aligned content to continue reinforcing and developing skills and concepts.

- 1) Together with student, complete one page (four squares) in the **Let's Connect** Multiplication and Division packet.
- 2) For any word problems, use the pink Word Problem Card (*found on the cart*) as a guide for how to talk about and work through the problems in a meaningful way.
- 3) Refer to the gray **Let's Connect** Multiplication & Division **Answer Key** (*found on the cart*) to check student work and answers.

## GOALS

*Student will be able to:*

Know from memory or quick reasoning products in Rows 1, 2, 4, 5 and 10 of the multiplication chart using visualization of groups (drawings, objects) and arrays, skip counting, the commutative property ( $2 \times 4 = 4 \times 2$ ), and the distributive property ( $4 \times 3 = 2 \times 3 + 2 \times 3$ ).

## ACTIVITIES

*The time required to complete each activity will vary from student to student. Allow student to move at his/her own pace. If more time is needed, lessons can be carried over to the next tutoring session.*

### Strategies for Learning Squares

### Fill in the Multiplication Chart (Review for 1, 2, 4, 5, 10 and squares)

### War with Array Cards

### Let's Connect

## MATERIALS ENCLOSED

Array Cards

## MATERIALS TO GET

Graph paper

Index Cards

Multiplication Chart (blank)

Paper and pencil

## IN PROGRESS FOLDER

Multiplication Chart (*partially filled from Lesson 8*)

Multiplication Combinations-to-Practice Envelope

Let's Connect Packet for Multiplication and Division

## WRAP-UP

- Make 2 or 3 "take-home" flash cards for combinations student is working on. Encourage student to review and practice these at home.
- Compliment student for hard work and provide stickers as a reward.
- Ask your student two of the following questions on the way back to class:
  - What was hard about today?
  - What did you feel confident about?
  - Where did you see improvement?
  - What do you still need to practice?
  - How do you feel about your effort today?
- Record brief notes on progress log.

## Strategies for Learning Squares

**Materials:** Multiplication Chart (*partially filled from Lesson 8 - saved in Student Progress Folder*)  
 Multiplication Combinations-to-Practice Envelope (*in Student Progress Folder*) / Graph paper /  
 Index cards / Pencil

**Purpose:** Student figures out the product of square combinations and relates them to other known combinations.

Tell student,

**“Today we are going to work on the “square” combinations. These are combinations that have the same number as both factors, such as  $2 \times 2$ ,  $3 \times 3$ ,  $4 \times 4$ ,  $5 \times 5$  etc... You already know some of these. Circle the square combinations you already have written on your chart.”**  $1 \times 1$ ,  $2 \times 2$ ,  $4 \times 4$ ,  $5 \times 5$ , and  $10 \times 10$

**“Can you guess why these are called ‘square’ combinations?”** *The array forms a square.*

Ask student to draw arrays on graph paper for all of the square combinations up to  $10 \times 10$  and to label them.

Then ask student to fill in the Multiplication Chart for the square combinations that are not already filled in.  $6 \times 6$ ,  $7 \times 7$ ,  $8 \times 8$ , and  $9 \times 9$

Ask,

**“What pattern do you see?”** *The products form a diagonal through the chart.*

### **3 x 3:**

Ask student to find the product for  $3 \times 3$  using each of these methods:

- Skip count: 3,6,9
- Start with a landmark (combination he/she knows easily):  $2 \times 3 = 6$  plus one more  $3 = 9$

Ask student to tell which method he/she finds most helpful.

Ask student to make a flash card, writing the factors on one side and the product on the other. (Drawing the array is not necessary.) Include the preferred strategy as a note on the product side of the card.

### **6 x 6:**

Ask student to find the product for  $6 \times 6$  using each of these methods:

- Skip count: 6, 12, 18, 24, 30, 36
- Start with a landmark:  $5 \times 6 = 30$  and one more  $6 = 36$
- Break one factor into parts – Using graph paper, help student divide a  $6 \times 6$  array into two parts as shown below:

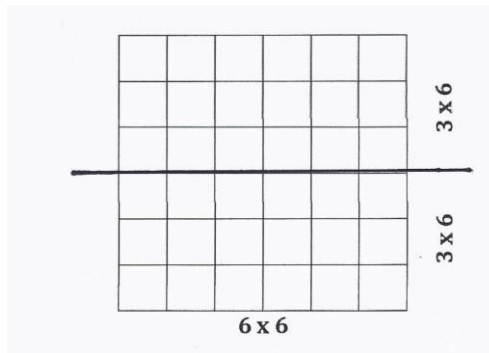

$$\begin{aligned}
 6 \times 6 &= (3 \times 6) + (3 \times 6) \\
 &= 18 + 18 \\
 &= 36
 \end{aligned}$$

Ask student to tell which method he/she finds most helpful.

Ask student to make a flash card, writing the factors on one side and the product on the other. (Drawing the array is not necessary.) Include the preferred strategy as a note on the product side of the card.

### **7 x 7**

Ask student to find the product for 7 x 7 by starting with a landmark: 7 x 5 = 35 and add 14 (two more 7s) to get 49.

Ask student to make a flash card, writing the factors on one side and the product on the other. (Drawing the array is not necessary.) Include the preferred strategy as a note on the product side of the card.

### **8 x 8**

Ask student to find the product for 8 x 8 using each of these methods:

- Start with a landmark: 8 x 5 = 40 plus 24 (3 more 8s) = 64
- Break one factor into parts – Using graph paper, help student divide an 8 x 8 array into two parts as shown below:

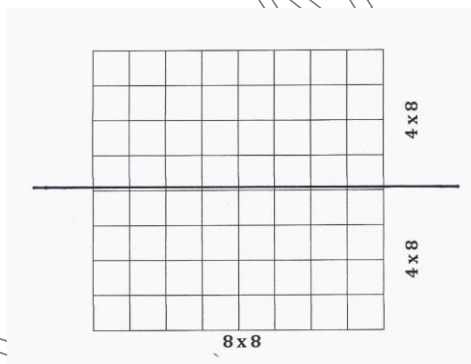

$$\begin{aligned}
 8 \times 8 &= (4 \times 8) + (4 \times 8) \\
 &= 32 + 32 = 64
 \end{aligned}$$

Ask student to tell which method he/she finds most helpful.

Ask student to make a flash card, writing the factors on one side and the product on the other. (Drawing the array is not necessary.) Include the preferred strategy as a note on the product side of the card.

### **9 x 9**

Ask student to find the product for  $9 \times 9$  by using a landmark: start with  $10 \times 9 = 90$  and take away one 9 to get 81. (Notice that the digits in 81 also add up to 9.)

**NOTE:** Show student that the above strategy can be used any time 9 is one of the factors in a problem since 9 groups of a number is one less group than 10 groups of that number.

$9 \times 8$  Start with  $10 \times 8 = 80$  and take away one 8 to get 72. (Notice  $7 + 2 = 9$ .)

$9 \times 7$  Start with  $10 \times 7 = 70$  and take away one 7 to get 63. (Notice  $6 + 3 = 9$ .)

$9 \times 6$  Start with  $10 \times 6 = 60$  and take away one 6 to get 54. (Notice  $5 + 4 = 9$ .)

$9 \times 5$  Start with  $10 \times 5 = 50$  and take away one 5 to get 45. (Notice  $4 + 5 = 9$ .)

Ask student to make a flash card, writing the factors on one side and the product on the other. (Drawing the array is not necessary.)

*PUT ALL FLASH CARDS IN THE MULTIPLICATION COMBINATIONS-TO-PRACTICE ENVELOPE IN STUDENT PROGRESS FOLDER.*

HEART MATH TUTORING



## Fill in the Multiplication Chart (Review for 1, 2, 4, 5, 10 and squares)

**Materials:** Multiplication Chart (blank) / Pencil

**Purpose:** Student practices recalling multiplication combinations using the Multiplication Chart.

Ask student to fill in Rows 1, 2, 4, 5, 10 of the Multiplication Chart and then to add the square combinations.

Ask student to fill in the opposites for combinations in Rows 1, 2, 4, 5 and 10 by filling in Columns 1, 2, 5 and 10, demonstrating the commutative property.

Ask student,

**“Are there opposite combinations to be filled for square combinations? Why or why not?”** *No. Because the opposites are the same as the original combinations.*

SAVE PARTIALLY FILLED MULTIPLICATION CHART IN STUDENT PROGRESS LOG TO USE IN NEXT LESSON.  
(Previously saved charts can be discarded.)

## War with Array Cards

**Materials:** Array Cards

**Purpose:** Student practices recalling multiplication combinations with fluency.

**NOTE:** Array Cards are divided by color into combination groups as shown below:

- Yellow=  $2x$ ,  $5x$ ,  $10x$
- Blue=  $4x$
- Green= Squares
- Pink=  $11x$
- White= all remaining combinations

Using the yellow, blue, and green Array Cards split the cards evenly between two players.

Both players turn over their top cards. Each player must say the product (answer) of his/her card. Use the words factor and product to reinforce vocabulary.

The player with the higher product takes both cards.

If the two players have equal products, both players turn over a second card to "beat the tie".

Continue until there are no more cards to turn over. The game can end here with the player holding the most cards as the winner.

Example cards

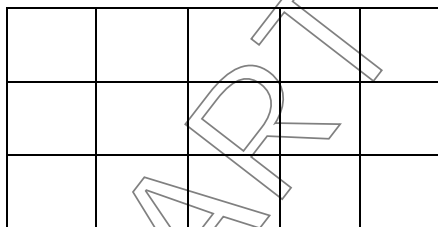

**$3 \times 5$**

**$5 \times 3$**

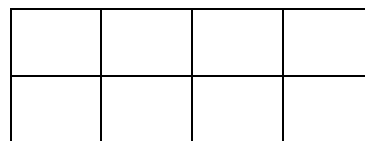

**$2 \times 4$**

**$4 \times 2$**

*"My product is 15 and your product is 8, so I take these cards."*

## Let's Connect!

**Materials:** Let's Connect Packet for Multiplication & Division (*enclosed in Student Progress Folder*) / Word Problem Guide Card (*pink card on cart*) / Paper and pencil

**Purpose:** Student practices standards-aligned content to continue reinforcing and developing skills and concepts.

- 1) Together with student, complete one page (four squares) in the **Let's Connect** Multiplication and Division packet.
- 2) For any word problems, use the pink Word Problem Card (*found on the cart*) as a guide for how to talk about and work through the problems in a meaningful way.
- 3) Refer to the gray **Let's Connect** Multiplication & Division **Answer Key** (*found on the cart*) to check student work and answers.

THIS LESSON IS A REVIEW OF THE PRIOR LESSON.

*Students who have strong knowledge of these combinations will move through these activities quickly and should move on to the next lesson.*

## ACTIVITIES

### Strategies for Learning the Remaining Combinations

#### Multiplying by 11

#### Name the Array and Make Flash Cards

#### Let's Connect

## MATERIALS ENCLOSED

Array Cards

## MATERIALS TO GET

Graph paper

Index cards

Paper and pencil

## IN PROGRESS FOLDER

Multiplication Combinations-to  
Practice Envelope

Multiplication Chart (*partially filled  
from Lesson 9*)

Let's Connect Packet for  
Multiplication and Division

## WRAP-UP

- Make 2 or 3 "take-home" flash cards for combinations student is working on. Encourage student to review and practice these at home.
- Compliment student for hard work and provide stickers as a reward.
- Ask your student two of the following questions on the way back to class:
  - What was hard about today?
  - What did you feel confident about?
  - Where did you see improvement?
  - What do you still need to practice?
  - How do you feel about your effort today?
- Record brief notes on progress log.

## Strategies for Learning the Remaining Combinations

**Materials:** Graph paper / Index cards / Multiplication Combinations-to-Practice Envelope (in Student Progress Folder) / Multiplication Chart (partially filled from Lesson 9, saved in Student Progress Log) / Pencil

**Purpose:** Student figures out the products for the remaining combinations up to  $10 \times 11$

Tell student,

**“Now you know most of your multiplication combinations (0s, 1s, 2s, 4s, 5s, 10s, and the square combinations). There are just a few more combinations to learn. We are going to work on these today.”**

### **3 x 6**

Ask student to figure out the product using each of the strategies below:

- Skip count by 3 (6 times): 3, 6, 9, 12, 15, 18
- Start with a landmark (a combination he/she already knows):  $2 \times 6 = 12$  plus one 6 = 18

**NOTE:** Help student see that 2 is an easy landmark to use when multiplying 3 times any number.

- Break one factor into parts – Using graph paper, help student divide a  $3 \times 6$  array into two parts as shown below:

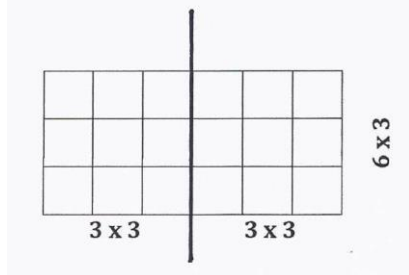

$$\begin{aligned} 3 \times 6 &= (3 \times 3) + (3 \times 3) \\ &= 9 + 9 = 18 \end{aligned}$$

Add the product to the multiplication chart.

Ask student which strategy he/she prefers.

Ask student to make a flash card, recording the factors in both orders on one side and the product on the other along with a note about student's preferred strategy.

### **3 x 7**

Ask student to figure out the product using each of the strategies below:

- Skip count by 3 (7 times): 3, 6, 9, 12, 15, 18, 21
- Start with a landmark using 2:  $2 \times 7 = 14$  plus one 7 = 21

Add the product to the multiplication chart.

Ask student which strategy he/she prefers.

Ask student to make a flash card, recording the factors in both orders on one side and the product on the other along with a note about student's preferred strategy.

### **3 x 8**

Ask student to figure out the product using each of the strategies below:

- Skip count by 3 (8 times): 3, 6, 9, 12, 18, 21, 24
- Start with a landmark using 2:  $2 \times 8 = 16$  plus one 8 = 24
- Break one factor into parts – Using graph paper, help student divide a  $3 \times 8$  array into two parts as shown below:

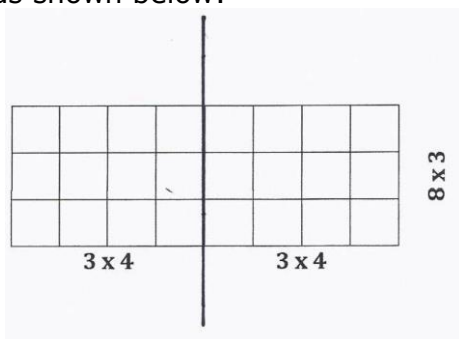

$$\begin{aligned} 3 \times 8 &= (3 \times 4) + (3 \times 4) \\ &= 12 + 12 \\ &= 24 \end{aligned}$$

Add the product to the multiplication chart.

Ask student which strategy he/she prefers.

Ask student to make a flash card, recording the factors in both orders on one side and the product on the other along with a note about student's preferred strategy.

### **3 x 9**

Ask student to figure out the product using each of the strategies below:

- Skip count by 3 (9 times): 3, 6, 9, 12, 18, 21, 24, 27
- Start with a landmark using 2:  $2 \times 9 = 18$ , plus one more 9 = 27
- Start with a landmark using 10:  $10 \times 3 = 30$  take away one 3 = 27

Add the product to the multiplication chart.

Ask student which strategy he/she prefers.

Ask student to make a flash card, recording the factors in both orders on one side and the product on the other along with a note about student's preferred strategy.

### **6 x 7**

Ask student to figure out the product using the strategy below:

- Start with a landmark using 5:
  - $5 \times 7 = 35$  plus one 7 = 42
  - $5 \times 6 = 30$  plus 12 (two more 6s) = 42

**NOTE:** Help student see that 5 is an easy landmark to use when multiplying 6 times any number.

Add the product to the multiplication chart.

Ask student to make a flash card, recording the factors in both orders on one side and the product on the other along with a note about strategy used.

### **6 x 8**

Ask student to figure out the product using each of the strategies below:

- Start with a landmark using 5:  $5 \times 8 = 40$  plus one 8 = 48
- Break one factor into parts – Using graph paper, help student divide a  $6 \times 8$  array into two parts as shown below:

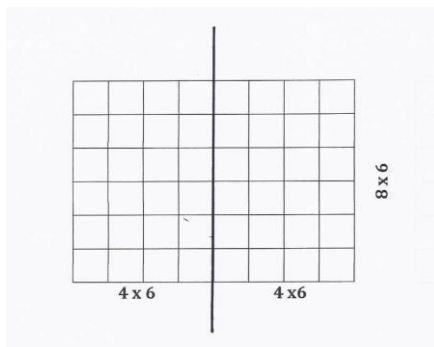

$$\begin{aligned} 6 \times 8 &= (6 \times 4) + (6 \times 4) \\ &= 24 + 24 \\ &= 48 \text{ (doubling 24)} \end{aligned}$$

Add the product to the multiplication chart.

Ask student which strategy he/she prefers.

Ask student to make a flash card, recording the factors in both orders on one side and the product on the other along with a note about student's preferred strategy.

### **6 x 9**

Ask student to figure out the product using each of the strategies below:

- Start with a landmark using 10:  $10 \times 6 = 60$ , take away one 6 = 54
- Start with a landmark using 5:  $5 \times 9 = 45$  plus one more 9 = 54

Add the product to the multiplication chart.

Ask student which strategy he/she prefers.

Ask student to make a flash card, recording the factors in both orders on one side and the product on the other along with a note about student's preferred strategy.

### **7 x 8**

Ask student to figure out the product using  $5 \times 8$  as a landmark:

- $5 \times 8 = 40$  plus two 8s = 56

Add the product to the multiplication chart.

Ask student to make a flash card, recording the factors in both orders on one side and the product on the other along with a note about the strategy used.

**7 x 9**

Ask student to figure out the product using  $10 \times 7$  as a landmark:

- $10 \times 7 = 70$  minus one  $7 = 63$

Add the product to the multiplication chart.

Ask student to make a flash card, recording the factors in both orders on one side and the product on the other along with a note about the strategy used.

**8 x 9**

Ask student to figure out the product using  $10 \times 8$  as a landmark:

- $10 \times 8 = 80$  minus one  $8 = 72$

Add the product to the multiplication chart.

Ask student to make a flash card, recording the factors in both orders on one side and the product on the other along with a note about the strategy used.

*PLACE ALL NEW FLASH CARDS IN THE MULTIPLICATION COMBINATIONS-TO-PRACTICE ENVELOPE.*

HEART MATH TUTORING



## Multiplying by 11

**Materials:** Index cards / Pencil

**Purpose:** Student learns how to solve multiplication problems with 11 as a factor.

### Multiplying 1 digit numbers by 11

Ask student if he/she has learned a rule about multiplying one-digit numbers by 11. Student may know that the product can be found by repeating the factor to create a two-digit number, such as  $3 \times 11 = 33$ .

To help student understand why this rule works, ask student to solve the following problems by using 10 as a landmark.

$$\underline{11 \times 2 = 22}$$

Start with a landmark:  $10 \times 2 = 20$  and one more 2 is 22.

$$\underline{11 \times 3 = 33}$$

Start with a landmark:  $10 \times 3 = 30$  and one more 3 is 33.

$$\underline{11 \times 8 = 88}$$

Start with a landmark:  $10 \times 8 = 80$  and one more 8 is 88.

### Multiplying 10 and 11 by 11

Explain, "**The simple rule of repeating digits does not work when multiplying a two-digit number x 11, but using 10 as a landmark still works.**"

Ask student to solve the following problems using 10 as a landmark.

$$\underline{11 \times 10 = 110}$$

Start with a landmark:  $10 \times 10 = 100$  and one more 10 is 110.

**NOTE:** Student could also solve by using the rule for multiplying by 10 - adding a 0 to 11.

$$\underline{11 \times 11 = 121}$$

Start with a landmark:  $11 \times 10 = 110$  and one more 11 is 121.

### Making Flash Cards

Quiz student on combinations to 11 and make flash cards for the combinations he/she needs to practice. Put these flash cards in the Multiplication Combinations-to-Practice Envelope.

## Name the Array and Make Flash Cards

**Materials:** Array Cards / Multiplication Combinations-to-Practice Envelope (*in Student Progress Folder*), Index Cards / Pencil

**Purpose:** Student practices recalling multiplication combinations with fluency.

**NOTE:** Array Cards are divided by color into combination groups as shown below:

- Yellow=  $2x$ ,  $5x$ ,  $10x$
- Blue=  $4x$
- Green= Squares
- Pink=  $11x$
- White= all remaining combinations

### **Round One: Name the Array**

Since student has only learned combinations for 2, 5, 10, and 4, use the yellow and blue Array Cards for this activity.

Mix the array cards and place them in a pile face down on the table.

Turn over the top card and ask student to tell the factors and product as quickly as possible without counting the squares.

If student gets the answer right, he/she keeps the card. If student gets the answer wrong, tutor keeps the card for use in making flash cards and to play Round Two.

Continue turning over cards with student saying the factors and product until all of the cards have been used.

### **Make Flash Cards for combinations that were missed:**

Have student use Index Cards to make flash cards for the combinations he/she missed in Round One. Write the factors both ways on one side (example:  $4 \times 5$  and  $5 \times 4$ ) and write the product on the other side (example: 20). Drawing the array is not necessary.

Place these cards in student's Multiplication Combinations-to-Practice Envelope and keep in his/her Progress Folder for practice in later lessons until he/she knows the combinations with consistency.

### **Round Two: Name the Array**

Use the array cards for the missed combinations in Round One to play the game again.

*If student knows all the combinations quickly, move ahead and begin the next Lesson.*

*If student needs more work on these combinations, replay this game and/or use the flash cards to review.*

## Let's Connect!

**Materials:** Let's Connect Packet for Multiplication & Division (*enclosed in Student Progress Folder*) / Word Problem Guide Card (*pink card on cart*) / Paper and pencil

**Purpose:** Student practices standards-aligned content to continue reinforcing and developing skills and concepts.

- 1) Together with student, complete one page (four squares) in the **Let's Connect** Multiplication and Division packet.
- 2) For any word problems, use the pink Word Problem Card (*found on the cart*) as a guide for how to talk about and work through the problems in a meaningful way.
- 3) Refer to the gray **Let's Connect** Multiplication & Division **Answer Key** (*found on the cart*) to check student work and answers.

# MULTIPLICATION FLUENCY LESSON 11

## GOALS

*Student will be able to:*

Know from memory or quick reasoning products in Rows 1, 2, 4, 5 and 10 of the multiplication chart and square combinations using visualization of groups (objects, drawings) and arrays, skip counting, the commutative property ( $2 \times 4 = 4 \times 2$ ), and the distributive property ( $4 \times 3 = 2 \times 3 + 2 \times 3$ ).

## ACTIVITIES

*The time required to complete each activity will vary from student to student. Allow student to move at his/her own pace. If more time is needed, lessons can be carried over to the next tutoring session.*

### **Fill in the Multiplication Chart (All Combinations)**

### **Race through the Worksheet #1**

### **The Product Game**

### **Let's Connect**

## MATERIALS ENCLOSED

Product Game Board

## MATERIALS TO GET

Connecting Cubes (2 bags of different colors)

Graph paper (3)

Index Cards

Pencil and paper

## IN PROGRESS FOLDER

Multiplication Chart (blank)

Multiplication Worksheet #1

Timer

Multiplication Combinations-to-Practice Envelope

Let's Connect Packet for Multiplication and Division

## WRAP-UP

- Make 2 or 3 "take-home" flash cards for combinations student is working on. Encourage student to review and practice these at home.
- Compliment student for hard work and provide stickers as a reward.
- Ask your student two of the following questions on the way back to class:
  - What was hard about today?
  - What did you feel confident about?
  - Where did you see improvement?
  - What do you still need to practice?
  - How do you feel about your effort today?
- Record brief notes on progress log.

## Fill the Multiplication Chart (All Combinations)

**Materials:** Multiplication Chart (blank) / Multiplication Combinations-to-Practice Envelope  
(in Student Progress Folder) / Index Cards / Pencil

**Purpose:** Student practices solving multiplication problems using the multiplication chart.

Ask student to fill out all rows of the Multiplication Chart. If you notice that your student is struggling with a particular combination, be sure there is already a flash card in the Multiplication Combinations-to-Practice Envelope in his/her Student Progress Folder. If not, make one.

## Race Through the Worksheet #1

**Materials:** Multiplication Combinations-to-Practice Envelope (*in Student Progress Folder*) / Index cards / Multiplication Worksheet #1 / Pencil / Timer (*use watch or clock, with second hand, or use stopwatch feature on phone*)

**Purpose:** Student practices recalling multiplication combinations with fluency.

Turn the Multiplication Worksheet #1 face down on the table and explain to student:

***"We are going to time you to see how fast you can race through this worksheet. Get your pencil ready. When I say "GO", turn over the worksheet and complete it as quickly as possible. On your mark, get set, GO!"***

If a combination is difficult for a student, take note. Once the student finishes, record his or her time in notes on the Progress Log.

Next, point out the combinations that were difficult for student. Discuss strategies from previous lessons to help student figure out these combinations quickly. Also - check to be sure student already has flash cards for these combinations in student's Combinations-to-Practice Envelope. If not, make them.

Student will complete a similar worksheet in Lesson 15. Compare his/her time to previous time and **celebrate improvements!**

Contact your Program Coordinator if you do not see progress or if you have other questions/concerns.

## The Product Game

**Materials:** Connecting Cubes (30/30) / Product Game Board / Pencil and Paper

**Purpose:** Student reviews multiplication combinations and practices thinking backwards from the products to the possible factors.

### Object of the Game:

To be the first player with 4 Connecting Cubes in a row - vertically, horizontally or diagonally.

### Directions:

1. Each player picks his/her own color of Connecting Cubes.
2. Player 1 chooses one of the factors listed at the bottom of the game board and places one of his/her Connecting Cubes below it. This will serve as a Marker.
3. Player 2 then chooses one of the factors and places one of his/her Connecting Cube below it as a second Marker. (Picking the same factor is allowed.)
4. Player 2 then figures out the product of the two marked factors and puts one of his/her Connecting Cubes (NOT his/her Marker) on the game board covering the product.
5. Player 1 chooses EITHER of the Markers at the bottom of the game board and moves it to another factor. He/she then puts one of his/her Connecting Cubes on the new resulting product.
6. Each player, in turn, continues to move a Marker and place another of his/her cubes on the resulting product. If a product is already covered, players may not put a cube there.
7. **The winner is the first player to mark four squares in a row – vertically, horizontally or diagonally.**

## Let's Connect!

**Materials:** Let's Connect Packet for Multiplication & Division (*enclosed in Student Progress Folder*) / Word Problem Guide Card (*pink card on cart*) / Paper and pencil

**Purpose:** Student practices standards-aligned content to continue reinforcing and developing skills and concepts.

- 1) Together with student, complete one page (four squares) in the **Let's Connect** Multiplication and Division packet.
- 2) For any word problems, use the pink Word Problem Card (*found on the cart*) as a guide for how to talk about and work through the problems in a meaningful way.
- 3) Refer to the gray **Let's Connect** Multiplication & Division **Answer Key** (*found on the cart*) to check student work and answers.



*Students who have strong knowledge of these combinations will move through these activities quickly and should move on to the next lesson.*

## ACTIVITIES

**War with Array Cards**

**Name the Missing Factor**

**Race through the Worksheet #2**

**Let's Connect**

## MATERIALS ENCLOSED

Array Cards

## MATERIALS TO GET

Connecting cubes (2 bags of different colors)

Deck of Cards

Index cards

Timer

Paper and pencil

Multiplication Worksheet #2

Name the Missing Factor  
Gameboard

## IN PROGRESS FOLDER

Multiplication Combinations-to-  
Practice Envelope

Let's Connect Packet for  
Multiplication and Division

## WRAP-UP

- Make 2 or 3 "take-home" flash cards for combinations student is working on. Encourage student to review and practice these at home.
- Compliment student for hard work and provide stickers as a reward.
- Ask your student two of the following questions on the way back to class:
  - What was hard about today?
  - What did you feel confident about?
  - Where did you see improvement?
  - What do you still need to practice?
  - How do you feel about your effort today?
- Record brief notes on progress log.

## War with Array Cards

**Materials:** Array Cards

**Purpose:** Student practices recalling multiplication combinations with fluency.

Using all of the Array Cards, split the cards evenly between two players.

**NOTE:** Array Cards are divided by color into combination groups as shown below:

- Yellow=  $2x$ ,  $5x$ ,  $10x$
- Blue=  $4x$
- Green= Squares
- Pink=  $11x$
- White= all remaining combinations

Split the cards evenly between two players.

Both players turn over their top cards. Each player must say the product (answer) of his/her card. Use the words factor and product to reinforce vocabulary.

The player with the higher product takes both cards.

If the two players have equal products, both players turn over a second card to "beat the tie".

Continue until there are no more cards to turn over. The game can end here with the player holding the most cards as the winner.

Example cards

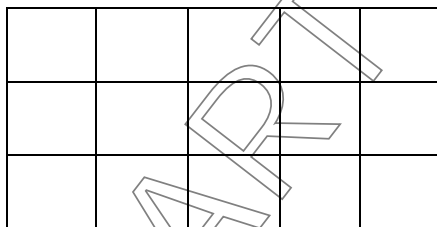

**$3 \times 5$**

**$5 \times 3$**

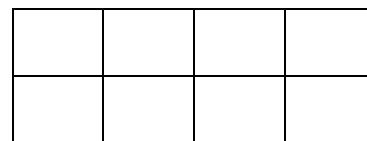

**$2 \times 4$**

**$4 \times 2$**

*"My product is 15 and your product is 8, so I take these cards."*

## Name the Missing Factor

**Materials:** Connecting Cubes (20/20) / Name the Missing Factor Game Board / Deck of Cards

**Purpose:** Student uses division (naming the missing factor) to practice multiplication combinations.

Use only the following playing cards (a total of 16): 6,7,8,9

Players pick a connecting cube color and decide who will go first.

Players then take turns turning over cards

If a player can think of a number to multiply with his/her playing card to create a product showing on the Game Board, the player covers the product with a connecting cube. If not, the player loses his/her turn.

Players continue to turn over cards and cover products until all the cards are used.

The player with the most cubes on the board is the winner.

**NOTE:** If student fails to recognize a product on the board that he/she would be able to cover, encourage him/her to keep looking and to try out different possible combinations that include his/her number.

## Race Through the Worksheet #2

**Materials:** Multiplication Combinations-to-Practice Envelope (*in Student Progress Folder*) / Index cards, Multiplication Worksheet #2 / Pencil / Timer (*use watch or clock, with second hand, or use stopwatch feature on phone*)

**Purpose:** Student practices recalling multiplication combinations with fluency.

Turn the Multiplication Worksheet #2 face down on the table and explain to student:

***"We are going to time you to see how fast you can race through this worksheet. Get your pencil ready. When I say "GO", turn over the worksheet and complete it as quickly as possible. On your mark, get set, GO!"***

If a combination is difficult for a student, take note. Once the student finishes, record his or her time on the Progress Log.

Next, point out the combinations that were difficult for student. Discuss strategies from previous lessons to help student figure out these combinations quickly. Also - check to be sure student already has flash cards for these combinations in student's Combinations-to-Practice Envelope. If not, make them.

Compare his/her time to previous time and **celebrate improvements!**

Contact your Program Coordinator if you do not see progress or if you have other questions/concerns.

## Let's Connect!

**Materials:** Let's Connect Packet for Multiplication & Division (*enclosed in Student Progress Folder*) / Word Problem Guide Card (*pink card on cart*) / Paper and pencil

**Purpose:** Student practices standards-aligned content to continue reinforcing and developing skills and concepts.

- 1) Together with student, complete one page (four squares) in the **Let's Connect** Multiplication and Division packet.
- 2) For any word problems, use the pink Word Problem Card (*found on the cart*) as a guide for how to talk about and work through the problems in a meaningful way.
- 3) Refer to the gray **Let's Connect** Multiplication & Division **Answer Key** (*found on the cart*) to check student work and answers.

## GOALS

*Student will be able to:*

Know from memory or quick reasoning products of remaining combinations using visualization of groups (objects, drawings) and arrays, skip counting, the commutative property ( $2 \times 4 = 4 \times 2$ ), and the distributive property ( $3 \times 9 = 3 \times 4 + 3 \times 5$ ).

## ACTIVITIES

*The time required to complete each activity will vary from student to student. Allow student to move at his/her own pace. If more time is needed, lessons can be carried over to the next tutoring session.*

### Flash Card Race

### Fluency Multiplication War with Cards

### Claim Your Territory

### Let's Connect

## MATERIALS ENCLOSED

None

## MATERIALS TO GET

Deck of Cards

2 Red Number Cubes (4-9)

Crayons (2 colors)

Graph paper

Index cards

Pencil

## IN PROGRESS FOLDER

Multiplication Combinations-to-Practice

Let's Connect Packet for  
Multiplication and Division

## WRAP-UP

- Make 2 or 3 "take-home" flash cards for combinations student is working on. Encourage student to review and practice these at home.
- Compliment student for hard work and provide stickers as a reward.
- Ask your student two of the following questions on the way back to class:
  - What was hard about today?
  - What did you feel confident about?
  - Where did you see improvement?
  - What do you still need to practice?
  - How do you feel about your effort today?
- Record brief notes on progress log.

## Flash Card Race

**Materials:** Multiplication Combinations-to-Practice Envelope (*in Student Progress Folder*) / Index cards / Pencil

**Purpose:** Student practices recalling multiplication combinations with fluency.

### **First Round:**

Show student each flash card from the Multiplication Combinations-to-Practice Envelope, holding them so that he/she can see only the side of the flash cards with the factors. Ask student to tell you the product as quickly as possible.

If student knows the combination immediately, place it into a separate pile. If student needs time to figure out the combination, return it to the Multiplication Combinations-to-Practice Envelope.

After going through all of the cards the first time, congratulate your student for the ones he/she knew immediately and recycle those flash cards or allow student to take them home.

### **Second Round:**

Now, play the game again (or several times) with the cards that were put back into the Multiplication Combinations-to-Practice Envelope. Even if student seems to know these by the end, place them back in the Multiplication Combinations to Practice Envelope so that you can check at a future lesson to make sure the student still recalls these combinations.

For combinations that are particularly difficult, return to the graph paper, Arrays, Multiplication Chart, Hundreds Chart or other helpful strategies from previous lessons.

## Multiplication War with Cards

**Materials:** Deck of cards / Index cards / Multiplication Combinations-to-Practice Envelope / Paper and pencil

**Purpose:** Student practices recalling multiplication combinations with fluency.

Remove all of the Kings and Queens from the deck.

Next, write on a piece of paper that  $A = 1$  and  $Jack = 0$  for this game only.

Shuffle the remaining cards and deal or divide them between you and student, leaving the two stacks face-down.

To play, each player turns over the top card on his/her stack at the same time. As quickly as possible, student will multiply the 2 cards together and say the answer. If the student gets it correct within 3 seconds, he/she may keep the cards in his/her winning pile. If it takes longer, the tutor keeps the cards. Before placing the cards in the winning pile, point out the commutative property and have student say the problem in both ways (Example:  $4 \times 5 = 20$  and  $5 \times 4 = 20$ ).

If you come across a combination that is difficult for your student, be sure the student has made a flash card for it in his/her Multiplication Combinations-to-Practice envelope. If not, make one.

If time permits, continue until student has all of the cards.

**NOTE:** Once student has completely mastered the 0s combinations, take out the Jacks. Do the same for the 1s, 2s, 5s and 10s. That will increase practice on the more difficult combinations.



## Claim Your Territory

**Materials:** 2 Red Number Cubes (4-9) / Graph Paper / Pencil / Crayons (2 colors)

**Purpose:** Student reviews a mix of multiplication combinations.

Fold one piece of graph paper in half horizontally. The tutor will use one color crayon on his/her half of the paper and the student will use a different color on his/her half.

Players take turns rolling two Red Number Cubes.

After rolling the cubes, the player must announce the product of the numbers shown and shade in an "array" of squares on his/her half of the graph paper to match that product. The number of rows and columns in the array may match the numbers showing on the cubes or it may be another array with the same product. (See example below.)

As the paper fills up, there will be less room for shading in squares.

The game is over when one player is "stuck" (unable to shade in the squares needed to make an array for his/her product). The person that does not get stuck is the winner.

Example:

If a player rolls 5 and 4, he/she would announce the product of 20. The player could then shade in an array of  $4 \times 5$ ,  $2 \times 10$  or  $20 \times 1$ , depending on the space he/she wants to fill.

## Let's Connect!

**Materials:** Let's Connect Packet for Multiplication & Division (*enclosed in Student Progress Folder*) / Word Problem Guide Card (*pink card on cart*) / Paper and pencil

**Purpose:** Student practices standards-aligned content to continue reinforcing and developing skills and concepts.

- 1) Together with student, complete one page (four squares) in the **Let's Connect** Multiplication and Division packet.
- 2) For any word problems, use the pink Word Problem Card (*found on the cart*) as a guide for how to talk about and work through the problems in a meaningful way.
- 3) Refer to the gray **Let's Connect** Multiplication & Division **Answer Key** (*found on the cart*) to check student work and answers.